

IRC5
RobotWare 5.13

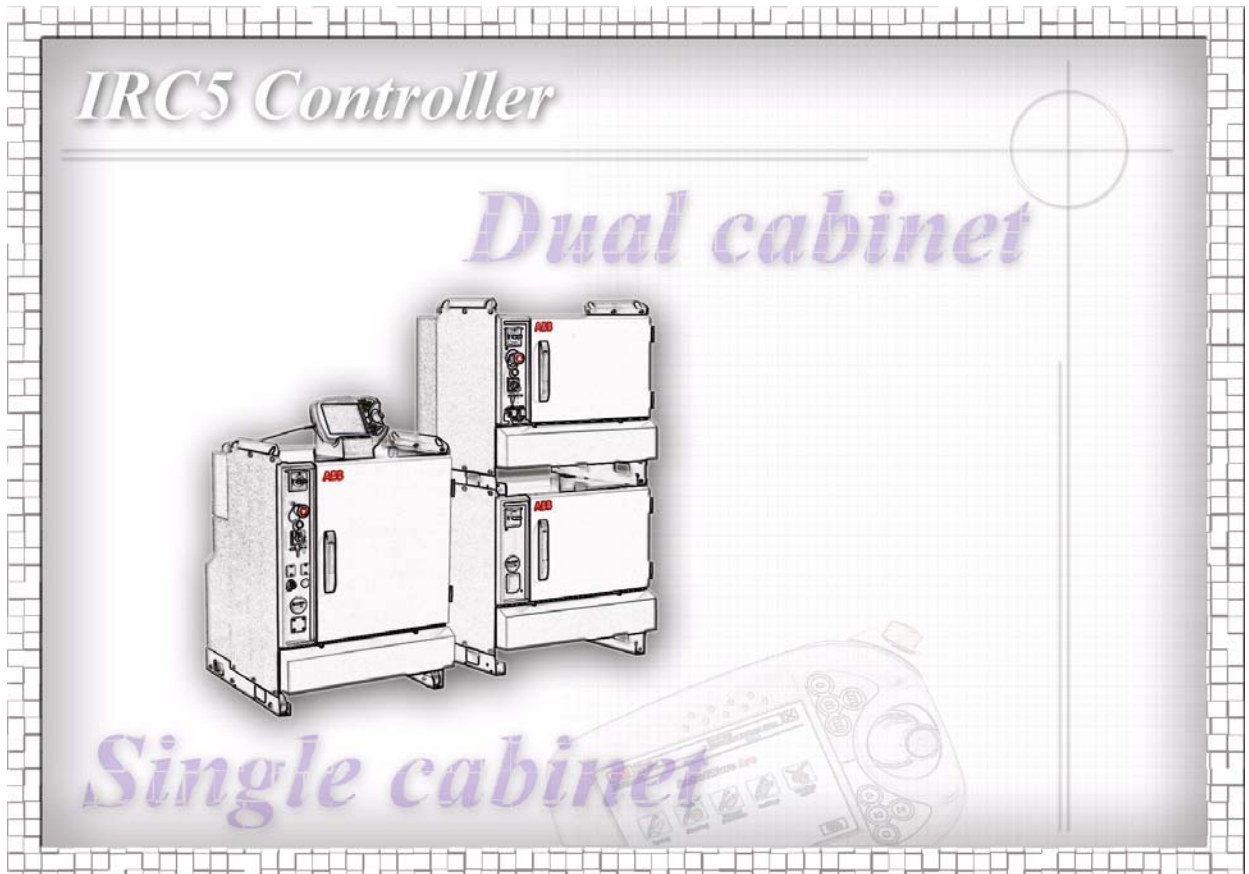

Product manual
Robot Controller
IRC5
M2004

Document ID: 3HAC021313-001

Revision: P

The information in this manual is subject to change without notice and should not be construed as a commitment by ABB. ABB assumes no responsibility for any errors that may appear in this manual.

Except as may be expressly stated anywhere in this manual, nothing herein shall be construed as any kind of guarantee or warranty by ABB for losses, damages to persons or property, fitness for a specific purpose or the like.

In no event shall ABB be liable for incidental or consequential damages arising from use of this manual and products described herein.

This manual and parts thereof must not be reproduced or copied without ABB's written permission, and contents thereof must not be imparted to a third party nor be used for any unauthorized purpose. Contravention will be prosecuted.

Additional copies of this manual may be obtained from ABB at its then current charge.

© Copyright 2004-2010 ABB All rights reserved.

ABB AB
Robotics Products
SE-721 68 Västerås
Sweden

Overview of this manual	7
Product documentation, M2004	11
1 Safety	13
1.1 Introduction to safety information	13
1.2 General safety information.	14
1.2.1 Introduction to general safety information	14
1.2.2 General Information	15
1.2.2.1 Safety in the manipulator system	15
1.2.3 Safety risks	16
1.2.3.1 Risks associated with live electric parts	16
1.2.4 Safety actions	17
1.2.4.1 Fire extinguishing	17
1.2.5 Safety stops.	18
1.2.5.1 Overview of manipulator stopping functions	18
1.2.5.2 What is an emergency stop?	23
1.2.5.3 What is a safety stop?	25
1.2.5.4 What is safeguarding?	27
1.3 Safety related instructions	28
1.3.1 Safety signals in the manual	28
1.3.2 DANGER - Make sure that the main power has been switched off!	30
1.3.3 WARNING - The unit is sensitive to ESD!	31
1.3.4 CAUTION - Never stand on or use the cabinet as a ladder	32
1.3.5 CAUTION - Make sure that there are no loose screws or turnings inside the computer unit DSQC639	33
1.3.6 CAUTION - Close the cabinet door.	34
1.3.7 CAUTION - Hot components in controller	35
2 Installation and Commissioning, IRC5	37
2.1 Overview	37
2.2 Installation Activities	38
2.3 Transporting and handling.	39
2.3.1 Lifting the controller modules	39
2.3.2 Unpacking the controller	40
2.4 On-site Installation	42
2.4.1 Required installation space, IRC5 Controller.	42
2.4.2 Bolting down the controller	43
2.4.3 Transportation screws.	44
2.4.4 Mounting the FlexPendant holder	45
2.5 Connections	49
2.5.1 Connectors on controller, IRC5	49
2.5.2 Connecting a FlexPendant	52
2.5.3 Connecting a PC to the service port	53
2.5.4 Connection to serial channel connector	55
2.5.5 Connecting power supply to the Single Cabinet Controller.	57
2.5.6 Connecting power supply to the Dual Cabinet Controller	61
2.5.7 Connecting the communication cabling for the Dual Cabinet Controller	63
2.5.8 Fitting the connector.	65
2.5.9 Connecting the manipulator to the IRC5 controller.	67
2.5.10 Connecting safety signals.	68
2.5.11 The MOTORS ON/MOTORS OFF circuit	69
2.5.12 Connection of external safety relay	74
2.5.13 Connection to MOTORS ON/MOTORS OFF contactor	75
2.5.14 Connection of Drive Module Disconnect, by limit switch.	77

2.5.15 Connection of servo disconnect, by servo power switch	81
2.5.16 Connecting a Limit switch override push button	83
2.6 Drive system	88
2.6.1 Drive functions, general	88
2.6.2 Drive System 04 or 09?	89
2.6.3 Configuration of Drive System 04, IRC5	91
2.6.4 Configuration of Drive System 09, IRC5	98
2.7 Memory functions	101
2.7.1 Memory functions	101
2.7.2 Connecting a USB memory to the computer unit	102
2.8 I/O system	104
2.8.1 Definition of I/O units, IRC5	104
2.9 Installation of add-ons	106
2.9.1 Installation of additional Drive Module	106
2.9.2 Installation of external operator's panel, IRC5	110
2.9.3 Installation of Drive system parts (Drive System 04)	114
2.9.4 Installation of Drive system parts (Drive System 09)	116
2.9.5 Installation of I/O, Gateways and encoder interface units, IRC5	118
2.9.6 Installation of PMC-card for Force Control Function (Drive System 04)	120
2.9.7 Installation of Force Control for Drive System 09	124
2.9.8 Upgrading and installation of 2X Euromap interface (Option 671-4)	125
2.9.9 Installation of cooling fan harness axis 1 and 2	134
2.9.10 Installation of Hot plug	139
2.9.11 Installing the EPS board DSQC 646 for Electronic Position Switches	146
2.9.12 Installing the SafeMove board DSQC 647	153
2.9.13 Installation of Remote Service	163
2.9.14 Installation of DispensePac support	165
3 Maintenance activities, controller IRC5	167
3.1 Maintenance schedule, controller IRC5	167
3.2 Inspection activities	168
3.2.1 Inspection of the controller	168
3.3 Changing/replacing activities	170
3.3.1 Activities	170
3.3.2 Replacement of moist dust filter	171
3.4 Cleaning activities	174
3.4.1 Cleaning of the controller cabinet	174
3.4.2 Cleaning moist dust filter	175
3.4.3 Cleaning the FlexPendant	176
4 Repair activities, controller IRC5	179
4.1 Overview	179
4.2 Replacement of panel board	180
4.3 Replacement of Flange disconnect	183
4.4 Replacement of I/O units and Gateways	186
4.5 Replacement of backup energy bank	189
4.6 Replacement of control system fan	192
4.7 Replacement of heat exchange unit and fan	196
4.8 Replacement of computer unit DSQC639	200
4.9 Replacement of motherboard in computer unit DSQC639	204
4.10 Replacement of DDR SDRAM memory on motherboard in computer unit DSQC639	207
4.11 Replacement of PCI boards in the computer unit DSQC639	211
4.12 Replacement of fieldbus adapter in the computer unit DSQC639	215

4.13 Replacement of fan in computer unit DSQC639	220
4.14 Replacement of Compact Flash memory in computer unit DSQC639	223
4.15 Replacement of servo drive units, rectifier and capacitor unit (Drive System 04)	226
4.16 Replacement of drive units (Drive System 09)	229
4.17 Replacement of Axis computer DSQC 601 (Drive System 04)	232
4.18 Replacement of Axis computer DSQC 668 (Drive System 09)	235
4.19 Replacement of EPS board DSQC 646	238
4.20 Replacement of SafeMove board DSQC 647	242
4.21 Replacement of Remote Service box	247
4.22 Replacement of integrated PLC	250
4.23 Replacement of Contactor Interface Board	252
4.24 Replacement of drive system fans	255
4.25 Replacement of transformer unit	258
4.26 Replacement of brake resistor bleeder	262
4.27 Replacement of Process Interface Board	268
4.28 Replacement of Ethernet switch	270
4.29 Replacement of power supply	272
4.29.1 Replacement of control power supply	272
4.29.2 Replacement of power distribution board	275
4.29.3 Replacement of customer I/O power supply, IRC5	278
4.29.4 Replacement of customer I/O power supply	281
4.29.5 Replacement of drive system power supply	284
4.29.6 Replacement of system power supply	287
5 Decommissioning	291
5.1 Introduction	291
5.2 Environmental information	292
6 Reference information, IRC5	293
6.1 Introduction	293
6.2 Applicable safety standards	294
6.3 Unit conversion	296
6.4 Screw joints	297
6.5 Weight specifications	298
6.6 Standard toolkit, IRC5	299
6.7 Lifting equipment and lifting instructions	300
7 Spare Parts	301
7.1 Controller parts	301
7.1.1 Single Cabinet Controller	301
7.2 Manipulator cables	308
7.2.1 Manipulator cables	308
7.2.2 Position switch cables	311
7.2.3 Fan cables	312
7.2.4 CP/CS Harness IRB 6400RF	313
7.2.5 CP/CS Harness IRB 4600, 6600, 7600, 660, 6620 and 6640	314
7.2.6 Customer signal, CS/CP and CS	315
7.2.7 Customer power-signal	316
7.2.8 Additional axis cables	317
8 Circuit Diagram	319
8.1 About circuit diagrams	319
Index	321

Overview of this manual

About this manual

This manual contains instructions for

- installing the controller, mechanically as well as electrically
- maintenance of the controller
- mechanical and electrical repair of the controller.

Usage

This manual should be used during

- installation, from lifting the controller cabinet to its work site and securing it to the foundation to making it ready for operation
- maintenance work
- repair work.

Who should read this manual?

This manual is intended for:

- installation personnel
- maintenance personnel
- repair personnel.

Prerequisites

A maintenance/repair/installation craftsman working with an ABB Robot must:

- be trained by ABB and have the required knowledge of mechanical and electrical installation/repair/maintenance work.

References

Reference	Document ID
Product manual - IRC5	3HAC021313-001
Emergency safety information	3HAC027098-001
Operating manual - IRC5 with FlexPendant	3HAC16590-1
Operating manual - RobotStudio	3HAC032104-001
Operating manual - Getting started, IRC5 and RobotStudio	3HAC027097-001
Operating manual - Trouble shooting	3HAC020738-001
Technical reference manual - System parameters	3HAC17076-1
Application manual - MultiMove	3HAC021272-001

Revisions

Revision	Description
-	First edition

Continues on next page

Continued

Revision	Description
D	<p>Updates made with the new computer unit DSQC 639 in sections:</p> <ul style="list-style-type: none"> • <i>Safety instructions</i> • <i>Connecting a PC to the service port</i> • <i>Connection to serial channel connector</i> • <i>Memory functions</i> • <i>Connecting a USB memory to the computer unit</i> • <i>Installation of external operator's panel, IRC5</i> <p>New sections added for the new computer unit DSQC 639:</p> <ul style="list-style-type: none"> • <i>Replacement of computer unit DSQC 639</i> • <i>Replacement of motherboard in computer unit DSQC 639</i> • <i>Replacements of PCI boards in computer unit DSQC 639</i> • <i>Replacement of fan in computer unit DSQC 639</i> • <i>Replacement of Compact Flash memory in computer unit DSQC639</i> • <i>Replacement of DDR SDRAM memory on motherboard in computer unit DSQC 639</i> <p>Minor corrections made in section <i>Installation of Euromap</i>.</p> <p>Installation of Hot plug button is described in the new section <i>Installation of Hot plug</i>.</p> <p>New Backup energy bank unit is included in section <i>Replacement of backup energy bank</i>.</p> <p>New DeviceNet Master/Slave boards are included in sections:</p> <ul style="list-style-type: none"> • <i>Definition of I/O units, IRC5</i> • <i>Replacement of I/O units and gateways</i> <p>Updates made with 6400RF in sections:</p> <ul style="list-style-type: none"> • <i>Configuration of the drive system, IRC5</i> • <i>Manipulator cables</i> <p>Circuit diagram is updated to revision 6.</p>
E	<p>New option Flange disconnect is described in the new section <i>Replacement of Flange disconnect</i>.</p> <p>New safety section <i>Close the cabinet door</i> added.</p> <p>New section <i>Connecting the communication cabling to the Dual Cabinet Controller</i> added.</p> <p>Minor corrections made.</p>

© Copyright 2004-2010 ABB. All rights reserved.

Continues on next page

Revision	Description
F	<p>New option Electronic Position Switches is described in the new section <i>Installing the EPS board for Electronic Position Switches</i> and section <i>Replacement of EPS board</i>.</p> <p>New option Dust filter is described in the new section <i>Replacement of dust filter</i> and <i>Cleaning dust filter</i>.</p> <p>New option EtherNet/IP Fieldbus Adapter is described in the new section <i>Replacement of fieldbus adapter in the computer unit DSQC 639</i>.</p> <p>New power supplies are described in the new sections <i>Replacement of power distribution board</i>, <i>Replacement of customer I/O power supply</i> and <i>Replacement of system power supply</i>.</p> <p>Circuit diagram for option EuroMap and SPI added.</p> <p>Minor corrections made.</p>
G	<p>New option PROFIBUS Fieldbus Adapter is added to section <i>Replacement of fieldbus adapter in the computer unit DSQC 639</i>.</p> <p>Minor corrections made.</p>
H	<p>Corrections in section <i>Spare Parts, Manipulator cables</i>. Circuit diagram is updated to revision 1.</p>
J	<p>New option SafeMove is described in the new section <i>Installing the SafeMove board DSQC 647</i> and section <i>Replacement of SafeMove board DSQC 647</i>.</p> <p>Changes made in section <i>Maintenance schedule, controller IRC5</i>. Replacement of fans every third year is withdrawn and inspection interval is changed from once a year to twice a year.</p> <p>Changes made in section <i>Installation of Euromap</i>.</p> <p>Updates made with IRB 360 in sections:</p> <ul style="list-style-type: none"> • <i>Configuration of the drive system, IRC5</i> • <i>Manipulator cables</i> <p>New option Remote Service is described in the new section <i>Installation of Remote Service</i> and section <i>Replacement of Remote Service box</i>.</p> <p>Minor corrections made.</p> <p>Circuit diagram updated to revision 2.</p>

Continued

Revision	Description
K	<p>New option PROFINET Fieldbus Adapter is added to section <i>Replacement of fieldbus adapter in the computer unit DSQC 639</i>.</p> <p>New option PROFINET master/slave is added to section <i>Replacements of PCI boards in computer unit DSQC 639</i>.</p> <p>New option Euromap II upgrade option 671-4 added in section <i>Installation of add-ons</i>.</p> <p>Filter time for safety stop AS/GS/SS is added in section <i>The MOTORS ON/MOTORS OFF circuit on page 69</i>.</p> <p>Instructions how to replace the brake resistor bleeder in the Dual Cabinet Controller, Drive Module is added to section <i>Replacement of brake resistor bleeder</i>.</p>
L	<p>Removed information about computer unit DSQC623, since the controller is no longer delivered with this computer unit.</p> <p>Removed section <i>Installation of Euromap and SPI</i>, since this is installed when the controller is delivered.</p> <p>New drive system introduced. Drive System 04 and Drive System 09 are both described.</p> <p>Added information about installation of DispensePac support and replacement of Process Interface Board and Ethernet switch.</p>
M	<p>The circuit diagram is replaced with an updated version including information about IRB 4600.</p>
N	<p>Added information about Drive System 09, including new drive units MDU-430A and ARU-430A. Units previously called HV MDU and HV ADU are renamed to MDU-790A and ADU-790A.</p> <p>Added information about IRB 6620, 6640, 6660, 6650S and 4600 in <i>Manipulator cables on page 308</i>. Removed unnecessary information about manipulator variants.</p> <p>Removed information about Drive unit connection from section <i>Configuration of Drive System 04, IRC5 on page 91</i>. This information is available in <i>Application manual - Additional axes and stand alone controller</i>.</p>
P	<p>Added chapter <i>Decommissioning on page 291</i>.</p> <p>Added section <i>Applicable safety standards on page 294</i>.</p> <p>Added info to <i>Storage conditions on page 40</i>.</p> <p>Added section <i>Replacement of integrated PLC on page 250</i>.</p> <p>Added section <i>Connecting safety signals on page 68</i>.</p> <p>Changed info regarding IRB 2400 in section <i>Configuration of Drive System 09, IRC5 on page 98</i>.</p> <p>Replaced compact flash memory card. 256MB card replaced with 1GB card.</p> <p>The chapter <i>Safety</i> updated with:</p> <ul style="list-style-type: none"> • Updated safety signal graphics for the levels <i>Danger</i> and <i>Warning</i>, see <i>Safety signals in the manual on page 28</i>. • Revised terminology: <i>robot</i> replaced with <i>manipulator</i>.

© Copyright 2004-2010 ABB. All rights reserved.

Product documentation, M2004

Categories for manipulator documentation

The manipulator documentation is divided into a number of categories. This listing is based on the type of information in the documents, regardless of whether the products are standard or optional.

All documents listed can be ordered from ABB on a DVD. The documents listed are valid for M2004 manipulator systems.

Product manuals

All hardware, manipulators and controllers will be delivered with a **Product manual** that contains:

- Safety information.
- Installation and commissioning (descriptions of mechanical installation, electrical connections).
- Maintenance (descriptions of all required preventive maintenance procedures including intervals).
- Repair (descriptions of all recommended repair procedures including spare parts).
- Additional procedures, if any (calibration, decommissioning).
- Reference information (article numbers for documentation referred to in Product manual, procedures, lists of tools, safety standards).
- Parts list.
- Foldouts or exploded views.
- Circuit diagrams (or references to circuit diagrams).

Technical reference manuals

The technical reference manuals describe the manipulator software in general and contain relevant reference information.

- **RAPID Overview:** An overview of the RAPID programming language.
- **RAPID Instructions, Functions and Data types:** Description and syntax for all RAPID instructions, functions, and data types.
- **RAPID Kernel:** A formal description of the RAPID programming language.
- **System parameters:** Description of system parameters and configuration workflows.

Application manuals

Specific applications (for example software or hardware options) are described in **Application manuals**. An application manual can describe one or several applications.

An application manual generally contains information about:

- The purpose of the application (what it does and when it is useful).
- What is included (for example cables, I/O boards, RAPID instructions, system parameters, CD with PC software).
- How to use the application.
- Examples of how to use the application.

Continues on next page

Continued

Operating manuals

The operating manuals describe hands-on handling of the products. The manuals are aimed at those having first-hand operational contact with the product, that is production cell operators, programmers, and trouble shooters.

The group of manuals includes:

- **Emergency safety information**
- **General safety information**
- **Getting started, IRC5 and RobotStudio**
- **IRC5 with FlexPendant**
- **RobotStudio**
- **Introduction to RAPID**
- **Trouble shooting**, for the controller and manipulator.

1 Safety

1.1. Introduction to safety information

Overview

The safety information in this manual is divided in two categories:

- General safety aspects, important to attend to before performing any service or installation work on the controller. These are applicable for all service work and are found in section *General safety information*.
- Specific safety information, pointed out in the procedure at the moment of the danger. How to avoid and eliminate the danger is either detailed directly in the procedure, or further detailed in separate instructions, found in section *Safety related instructions on page 28*.

1 Safety

1.2.1. Introduction to general safety information

1.2 General safety information

1.2.1. Introduction to general safety information

Definitions

This section details general safety information for personnel performing installation, repair and maintenance work.

Sections

The general safety information is divided into the following sections.

Contents	Containing
General information	<ul style="list-style-type: none">• safety, service• limitation of liability• related information
Safety risks (lists dangers relevant when working with the controller. The dangers are split into different categories).	<ul style="list-style-type: none">• safety risks during installation or service• risks associated with live electrical parts
Safety actions (describes actions which may be taken to remedy or avoid dangers).	<ul style="list-style-type: none">• fire extinguishing• safe use of the FlexPendant
Safety stops (describes different types of stops).	<ul style="list-style-type: none">• stopping functions• description of emergency stop• description of safety stop• description of safeguarding

1.2.2. General Information

1.2.2.1. Safety in the manipulator system

Validity and responsibility

The information does not cover how to design, install and operate a complete system, nor does it cover all peripheral equipment that can influence the safety of the total system. To protect personnel, the complete system must be designed and installed in accordance with the safety requirements set forth in the standards and regulations of the country where the manipulator is installed.

The users of ABB industrial manipulators are responsible for ensuring that the applicable safety laws and regulations in the country concerned are observed and that the safety devices necessary to protect people working with the manipulator system are designed and installed correctly. Personnel working with manipulators must be familiar with the operation and handling of the industrial manipulator as described in the applicable documents, for example:

- *Operating manual - IRC5 with FlexPendant*
- *Product manual*

Connection of external safety devices

Apart from the built-in safety functions, the manipulator is also supplied with an interface for the connection of external safety devices. Via this interface, an external safety function can interact with other machines and peripheral equipment. This means that control signals can act on safety signals received from the peripheral equipment as well as from the manipulator.

Limitation of liability

Any information given in this manual regarding safety must not be construed as a warranty by ABB that the industrial manipulator will not cause injury or damage even if all safety instructions are complied with.

Related information

Type of information	Detailed in document	Section
Installation of safety devices	Product manual for the manipulator	Installation and commissioning
Changing operating modes	Operating manual - IRC5 with FlexPendant	Operating modes
Restricting the working space	Product manual for the manipulator	Installation and commissioning

1 Safety

1.2.3.1. Risks associated with live electric parts

1.2.3. Safety risks

1.2.3.1. Risks associated with live electric parts

Voltage related risks, general

- Although troubleshooting may, on occasion, need to be carried out while the power supply is turned on, the robot must be turned off (by setting the mains switch to OFF) when repairing faults, disconnecting electric leads and disconnecting or connecting units.
- The mains supply to the robot must be connected in such a way that it can be turned off from outside the robot's working space.

Voltage related risks, IRC5 controller

A danger of high voltage is associated with, for example, the following parts:

- Be aware of stored electrical energy (DC link, Ultracapacitor bank unit) in the controller.
- Units such as I/O modules, can be supplied with power from an external source.
- The mains supply/mains switch
- The transformers
- The power unit
- The control power supply (230 VAC)
- The rectifier unit (400-480 VAC and 700 VDC. Note: Capacitors!)
- The drive unit (700 VDC)
- The drive system power supply (230 VAC)
- The service outlets (115/230 VAC)
- The customer power supply (230 VAC)
- The power supply unit for additional tools, or special power supply units for the machining process.
- The external voltage connected to the controller remains live even when the robot is disconnected from the mains.
- Additional connections.

Voltage related risks, tools, material handling devices, etc.

Tools, material handling devices, etc., may be live even if the robot system is in the OFF position. Power supply cables which are in motion during the working process may be damaged.

1.2.4. Safety actions

1.2.4.1. Fire extinguishing



NOTE!

Use a CARBON DIOXIDE (CO₂) extinguisher in the event of a fire in the manipulator system (manipulator or controller)!

1 Safety

1.2.5.1. Overview of manipulator stopping functions

1.2.5. Safety stops

1.2.5.1. Overview of manipulator stopping functions

Overview

Stops are categorized/classified by standards IEC 60204-1:2005 and ISO 10218-1:2006.

There are several different manipulator stopping functions in the manipulator system.

- Hardware stops connected to the run chain.
- Manual stops.
- Stop with system input signals.
- Stop with RAPID instructions.
- System failure stops.

Stop modes

Stops can be in uncontrolled or controlled mode. The stop mode is configured with system parameters, see [Soft stops on page 19](#).

Uncontrolled stop	This is related to stop category 0 as described in IEC 60204-1:2005, which means that power is removed immediately from the drive units, by releasing the run chain through the software enable signal, and the brakes are activated. Also the servo motors are used for the braking, by reversing to "generator" and ramping down the generated power in a controlled way. In this way, both the brakes and the motors are used to stop the manipulator, giving the shortest possible stop time and stop distance. However, it also means that the manipulator mechanics will be highly stressed and the manipulator will leave the programmed path and stop at an uncontrolled position.
Controlled stop	This is related to stop category 1 as described in IEC 60204-1:2005. It means that the power will be connected to the drive units for about 1 second, by a hardware delay, and the movement will be put to a full stop using the servo motors before the power is removed and the brakes are activated. This way the manipulator will stop at a controlled point on or very close to the programmed path. The controlled stop is also called "soft" because it will be more soft for the mechanics, but note, it is the same as a <i>QuickStop</i> when initiated via a system input, see below.

Hardware stops connected to the run chain

There are several hardware stops available. All these stops are of safety category 3 as described in EN 954-1 or EN 13849-1, that is double channel initiated stop.

Stop connections:	Description:
Emergency stop	Disconnects drive power in all operating modes.
Automatic mode stop	Disconnects drive power in automatic operating mode. To be used as <i>Protective stop</i> in auto. Also called <i>Safety stop</i> . In manual mode this input connection will be inactive.

Continues on next page

Continued

Stop connections:	Description:
General stop	Disconnects drive power in all operating modes. To be used as <i>Protective stop</i> in all operating modes. Also called <i>Safety stop</i> .
Superior stop	Disconnects drive power in all operating modes. To be used as <i>Protective stop</i> in all operating modes. Also called <i>Safety stop</i> . Intended for external equipment.

Soft stops

The stop mode for hardware stops is configured with system parameters, one parameter for each stop. Each of these parameters can have the value TRUE or FALSE (true or false). If TRUE the stop will be controlled or soft, that is category 1, if FALSE it will be uncontrolled, that is category 0, (see exception below). Default values are TRUE for SoftAS, SoftGS, and SoftSS, and FALSE for SoftES. The parameters are of the type *Safety Run Chain* in the topic *Controller*. The following descriptions apply if the values are set to TRUE.

Soft Stop:	Description:
SoftES	Soft emergency stop is activated by pressing the emergency stop push button on the FlexPendant or the control module. SoftES is only used in auto. In manual mode, emergency stop will be a category 0 stop regardless if the value is TRUE or FALSE.
SoftAS	Soft automatic mode stop is intended for automatic mode during normal program execution. This stop is activated by safety devices such as light curtains, light beams, or sensitive mats.
SoftGS	Soft general stop is activated by safety devices such as light curtains, light beams, or sensitive mats.
SoftSS	Soft superior stop has the same function as a general stop but is intended for externally connected safety devices.

Manual stops

A manual stop is initiated by a person. It can be a controlled or an uncontrolled stop depending on how the stop is initiated.

Stop mode:	Manual stop:	Description:
Controlled	Stop button on FlexPendant or Release of Hold-to-run function	This will stop program execution and cause an immediate stop of manipulator movements in all tasks. The manipulators will stop in a controlled way and on the path with no deviation. This is called normal program stop.
Uncontrolled	Release of enabling device or Switching operating mode key	This will stop program execution and stop all program movements.

Continues on next page

1 Safety

1.2.5.1. Overview of manipulator stopping functions

Continued

Stop with system input signals

In addition to the hardware stops as described above, it is also possible to define system input signals, which will give an immediate or delayed stop of different modes for all tasks and manipulators, when activated. Such signals are defined as system parameters of the type *System Input* in the topic *I/O* and for the following stop modes.

Stop mode:	Description:
Stop	Stops the RAPID program execution. All manipulator movements will be stopped on the path with no deviation. A program cannot be started when this signal is high. This stop is similar to a normal program stop using stop button on the FlexPendant.
QuickStop	Stops the RAPID program execution quickly, like a controlled category 1 emergency/safety stop. This stop is performed by ramping down motion as fast as possible using optimum motor performance. The different axes are still coordinated to trying to keep the manipulator on path even if it may slide off by some millimeters. Note, this kind of stop is more stressing for the mechanics than normal stop or SoftStop.
SoftStop	Stops the RAPID program execution much like an ordinary program stop, but slightly faster. The stop is performed by ramping down motion in a controlled and coordinated way, to keep the manipulator on the programmed path with minor deviation. This kind of stop is more soft to the mechanics than the QuickStop.
Stop at End of Cycle	Stops the RAPID program when the complete program is executed, that means when the last instruction in the main routine has been completed.
Stop at End of Instruction	Stops program execution after the current instruction is completed.

All of these stops are performed without using the brakes, and the power is never disconnected. The program execution can be continued directly, for example by activating a start signal.

NOTE!

Note, these stops shall not be used as safety stops, as they are not fulfilling safety category 3.



Stop with RAPID instructions

There are several RAPID instructions available that stops the manipulator.

Instruction:	Description:	Arguments:
SystemStopAction	Stops all manipulators in all tasks immediately.	<p>\Stop - similar to a normal program stop with stop button.</p> <p>\StopBlock - as above, but to restart the PP has to be moved.</p> <p>\Halt - this is like a category 0 stop, i.e. it will result in motors off state, stop of program execution and manipulator movements in all motion tasks. The Motors on button must be pressed before the program execution can be restarted.</p>
Stop	The current move instruction will be finished before the manipulator stops. A restart will continue the program execution.	<p>\NoRegain - the manipulator will not return to the stop point when restarted, e.g. after having been jogged away.</p> <p>\AllMoveTasks - all manipulators will be stopped</p>
StopMove	The current move instruction will be stopped immediately as a normal program stop but the program execution will continue with the next instruction. This is often used in for example trap routines.	<p>\Quick - the stop will be a soft stop on path, as described above for system input SoftStop, otherwise similar to a normal program stop.</p> <p>\AllMotionTasks - all manipulators will be stopped</p>
BREAK	The current move instruction and the program execution will be stopped immediately as a normal program stop. A restart will continue the program execution.	
EXIT	The current move instruction and the program execution will be stopped immediately as a normal program stop. After stop the Program Pointer has to be reset to Main.	
EXITCYCLE	The current move instruction and program execution will be stopped immediately. The Program Pointer will be reset to Main and if running mode is continuous, the program will be restarted.	

1 Safety

1.2.5.1. Overview of manipulator stopping functions

Continued

Instruction:	Description:	Arguments:
SearchX	Search instructions can be programmed with arguments to stop the manipulator movement close to the point where a search hit was noticed. The program execution will continue with the next instruction.	<p>\Stop - the manipulator will stop as fast as possible. This stop is performed by ramping down motion in each motor separate from each other, and as fast as possible. Since it will be without any coordination, the manipulator may slide off path fairly much. This is also called StiffStop.</p> <p>\PStop - the manipulator will stop like after a normal program stop.</p> <p>\SStop - the manipulator will stop on path but quicker than a normal program stop. This is similar to a system input SoftStop.</p> <p>\Sup - the manipulator will continue to the ToPoint. If more than one search hit is found, an error will be reported.</p>

RAPID instructions are described in *Technical reference manual - RAPID Instructions, Functions and Data types*.

System failure stops

Type of stop:	Description:
SysFail	In event of system failure raising a SysFail error the manipulator will stop immediately, with brakes being activated. This is an uncontrolled stop category 0.
Power fail	In event of power failure the manipulator will stop immediately, with brakes being activated. This is an uncontrolled stop category 0.
Stop at collision	<p>When a collision is detected the manipulator will stop immediately, with power disconnected from the drive units and the brakes activated.</p> <p>After full stop the power is reconnected and the residual forces are relieved by moving the manipulator in the reversed direction a short distance back to its path. Then the program execution will stop with an error message.</p> <p>The manipulator remains in the state Motors on so that program execution can be resumed after the collision error message has been acknowledged.</p> <p>This is an uncontrolled stop category 0.</p>

© Copyright 2004-2010 ABB. All rights reserved.

1.2.5.2. What is an emergency stop?

Definition of emergency stop

An emergency stop is a state that overrides any other manipulator control, disconnects drive power from the manipulator motors, stops all moving parts and disconnects power from any potentially dangerous functions controlled by the manipulator system.

An emergency stop state means that all power is disconnected from the manipulator except for the manual brake release circuits. You must perform a recovery procedure, i.e. resetting the emergency stop button and pressing the Motors On button, in order to return to normal operation.

The manipulator system can be configured so that the emergency stop results in either:

- An uncontrolled stop, immediately stopping the manipulator actions by disconnecting power from the motors.
- A controlled stop, stopping the manipulator actions with power available to the motors so that the manipulator path can be maintained. When completed, power is disconnected.

The default setting is uncontrolled stop. However, controlled stops are preferred since they minimize extra, unnecessary wear on the manipulator and the actions needed to return the manipulator system back to production. Please consult your plant or cell documentation to see how your manipulator system is configured.



NOTE!

The emergency stop function may only be used for the purpose and under the conditions for which it is intended.



NOTE!

The emergency stop function is intended for immediately stopping equipment in the event of an emergency.



NOTE!

Emergency stop should not be used for normal program stops as this causes extra, unnecessary wear on the manipulator. For how to perform normal program stops, see the section *Stopping programs* in *Operating manual - IRC5 with FlexPendant*.

Classification of stops

The safety standards that regulate automation and manipulator equipment define categories in which each type of stop applies:

If the stop is...	... then it is classified as...
uncontrolled	category 0 (zero)
controlled	category 1

Continues on next page

1 Safety

1.2.5.2. What is an emergency stop?

Continued

Emergency stop devices

In a manipulator system there are several emergency stop devices that can be operated in order to achieve an emergency stop. There are emergency stop buttons available on the FlexPendant and on the controller cabinet (on the Control Module on a Dual Cabinet Controller). There can also be other types of emergency stops on your manipulator. Consult your plant or cell documentation to see how your manipulator system is configured.

1.2.5.3. What is a safety stop?

Definition of safety stops

A safety stop means that only the power to the manipulator motors is disconnected. There is no recovery procedure. You need only to restore motor power to recover from a safety stop. Safety stop is also called protective stop.

The manipulator system can be configured so that the stop results in either:

- An uncontrolled stop, immediately stopping the manipulator actions by disconnecting power from the motors.
- A controlled stop, stopping the manipulator actions with power available to the motors so that the manipulator path can be maintained. When completed, power is disconnected.

The default setting is controlled stop.

Controlled stops are preferred since they minimize extra, unnecessary wear on the robot and the actions needed to return the robot system back to production. Please consult your plant or cell documentation to see how your robot system is configured.



NOTE!

The safety stop function may only be used for the purpose and under the conditions for which it is intended.



NOTE!

Safety stop should not be used for normal program stops as this causes extra, unnecessary wear on the manipulator. For how to perform normal program stops, see section *Stopping programs* in *Operating manual - IRC5 with FlexPendant*.

Classification of stops

The safety standards that regulate automation and manipulator equipment define categories in which each type of stop applies:

If the stop is...	... then it is classified as...
uncontrolled	category 0 (zero)
controlled	category 1

Type of safety stops

Safety stops are activated through special signal inputs to the controller, see *Product manual - IRC5*. The inputs are intended for safety devices such as cell doors, light curtains, or light beams.

Safety stop:	Description:
Automatic mode stop (AS)	Disconnects drive power in automatic mode. In manual mode this input is inactive.
General stop (GS)	Disconnects drive power in all operating modes.
Superior stop (SS)	Disconnects drive power in all operating modes. Intended for external equipment.

Continues on next page

1 Safety

1.2.5.3. What is a safety stop?

Continued



NOTE!

Use normal program stop for all other types of stop.

1.2.5.4. What is safeguarding?

Definition

Safeguarding are safety measures consisting of the use of safeguards to protect persons from hazards which cannot reasonably be removed or sufficiently eliminated by design.

A safeguard prevents hazardous situations by stopping the manipulator in a controlled manner when a certain safeguarding mechanism such as a light curtain is activated. This is done by connecting the safeguard to any of the safety stop inputs at the manipulator controller.

The safety stops described in *What is a safety stop? on page 25*, should be used for safeguarding.

**NOTE!**

The safeguarding function may only be used for the purpose and under the conditions for which it is intended.

**NOTE!**

The safeguarding function should not be used for normal program stops as this causes extra, unnecessary wear on the manipulator. For how to perform normal program stops, see section *Stopping programs in Operating manual - IRC5 with FlexPendant*.

Safeguarded space

The safeguarded space is the space guarded by the guards. For example, a manipulator cell is safeguarded by the cell door and its interlocking device.

Interlocking devices

Each present guard has an interlocking device which, when activated stops the manipulator. The manipulator cell door has an interlock that stops the manipulator when the door is opened. The only way to resume operation is to close the door.

Safeguarding mechanisms

A safeguarding mechanism consists of a number of guards connected in series. When a guard is activated, the chain is broken and the machine operation is stopped regardless of the state of the guards in the rest of the chain.

**NOTE!**

Use normal program stop for all other types of stop.

1 Safety

1.3.1. Safety signals in the manual

1.3 Safety related instructions

1.3.1. Safety signals in the manual





Introduction to safety signals

This section specifies all dangers that can arise when doing the work described in this manual. Each danger consists of:

- A caption specifying the danger level (DANGER, WARNING, or CAUTION) and the type of danger.
- A brief description of what will happen if the operator/service personnel **do not** eliminate the danger.
- An instruction on how to eliminate the danger to simplify doing the work.

Danger levels



The table below defines the captions specifying the danger levels used throughout this manual.

Symbol	Designation	Significance
	DANGER	Warns that an accident <i>will</i> occur if the instructions are not followed, resulting in a serious or fatal injury and/or severe damage to the product. It applies to warnings that apply to danger with, for example, contact with high voltage electrical units, explosion or fire risk, risk of poisonous gases, risk of crushing, impact, fall from height, etc.
	WARNING	Warns that an accident <i>may</i> occur if the instructions are not followed that can lead to serious injury, possibly fatal, and/or great damage to the product. It applies to warnings that apply to danger with, for example, contact with high voltage electrical units, explosion or fire risk, risk of poisonous gases, risk of crushing, impact, fall from height, etc.
	ELECTRICAL SHOCK	Warns for electrical hazards which could result in severe personal injury or death.
	CAUTION	Warns that an accident may occur if the instructions are not followed that can result in injury and/or damage to the product. It also applies to warnings of risks that include burns, eye injury, skin injury, hearing damage, crushing or slipping, tripping, impact, fall from height, etc. Furthermore, it applies to warnings that include function requirements when fitting and removing equipment where there is a risk of damaging the product or causing a breakdown.

© Copyright 2004-2010 ABB. All rights reserved.

Continues on next page

Continued

Symbol	Designation	Significance
 Electrostatic discharge (ESD)	ELECTROSTATIC DISCHARGE (ESD)	Warns for electrostatic hazards which could result in severe damage to the product.
 Note	NOTE	Describes important facts and conditions.
 Tip	TIP	Describes where to find additional information or how to do an operation in an easier way.

1 Safety

1.3.2. DANGER - Make sure that the main power has been switched off!

1.3.2. DANGER - Make sure that the main power has been switched off!

Description

Working with high voltage is potentially lethal. Persons subjected to high voltage may suffer cardiac arrest, burn injuries, or other severe injuries. To avoid these dangers, do not proceed working before eliminating the danger as detailed below.

Elimination, Single Cabinet Controller

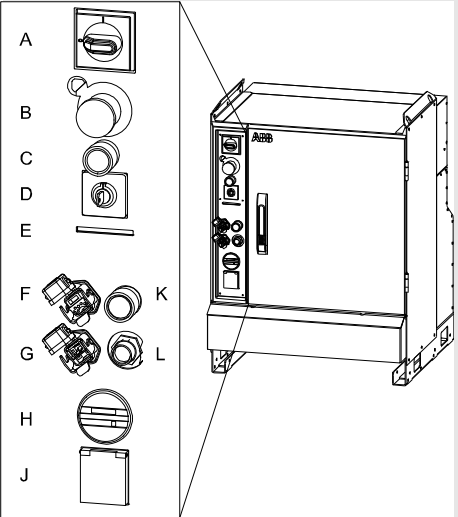
Action	Note/illustration
1. Switch off the main switch on the controller cabinet.	 <p>xx0600002782</p> <p>A: Main switch</p>

Elimination, Dual Cabinet Controller

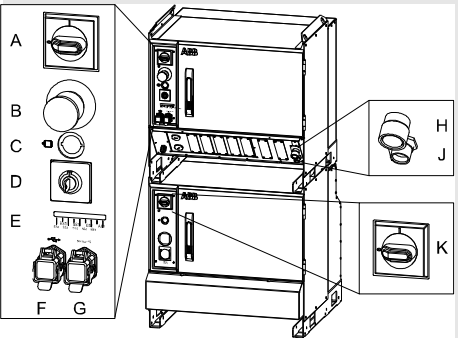
Action	Note/illustration
1. Switch off the main switch on the Control Module.	 <p>xx0600002783</p> <p>A: Main switch, Control Module</p>
2. Switch off the main switch on the Drive Module.	<p>K: Main switch, Drive Module (see illustration above)</p>

© Copyright 2004-2010 ABB. All rights reserved.

1.3.3. WARNING - The unit is sensitive to ESD!

Description

ESD (electrostatic discharge) is the transfer of electrical static charge between two bodies at different potentials, either through direct contact or through an induced electrical field. When handling parts or their containers, personnel not grounded may potentially transfer high static charges. This discharge may destroy sensitive electronics.

Elimination

	Action	Note
1.	Use a wrist strap	Wrist straps must be tested frequently to ensure that they are not damaged and are operating correctly.
2.	Use an ESD protective floor mat.	The mat must be grounded through a current-limiting resistor.
3.	Use a dissipative table mat.	The mat should provide a controlled discharge of static voltages and must be grounded.

Location of wrist strap button

The location of the wrist strap button is shown in the following illustration.

IRC5

The wrist strap button is located in the top right corner.

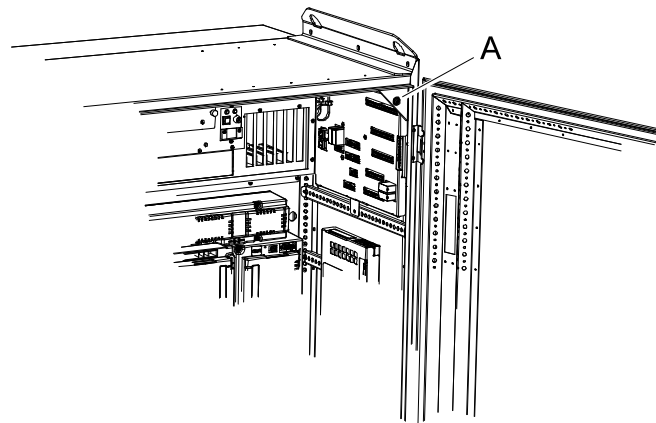

xx0500002171

A Wrist strap button

1 Safety

1.3.4. CAUTION - Never stand on or use the cabinet as a ladder

1.3.4. CAUTION - Never stand on or use the cabinet as a ladder

Description

To avoid personal injury or damaging the product, it is never allowed to stand on the single cabinet or the modules of the dual cabinet. Nor is it allowed to use the single cabinet or the modules of the dual cabinet as a ladder.

1.3.5. CAUTION - Make sure that there are no loose screws or turnings inside the computer unit DSQC639

1.3.5. CAUTION - Make sure that there are no loose screws or turnings inside the computer unit DSQC639

Description

To avoid damaging the product, do not proceed working before checking that there are no loose screws, turnings or other parts inside the computer unit after work has been performed inside the controller cabinet.

1 Safety

1.3.6. CAUTION - Close the cabinet door

1.3.6. CAUTION - Close the cabinet door

Description

The cabinet door must be closed properly when the manipulator system is in production. If a door is not properly closed, the cabinet does not comply with the protection class IP54. The shield for Electro Magnetic Compatibility is also affected if the door is not properly closed.

1.3.7. CAUTION - Hot components in controller

Description

Units and heat sinks are HOT after running the manipulator!

Touching the units and heat sinks may result in burns!

With higher environment temperature more surfaces on the controller get HOT and may result in burns.

1 Safety

1.3.7. CAUTION - Hot components in controller

2 Installation and Commissioning, IRC5

2.1. Overview

General

The ABB IRC5 controller is available in two basic configurations: Single Cabinet Controller and Dual Cabinet Controller.

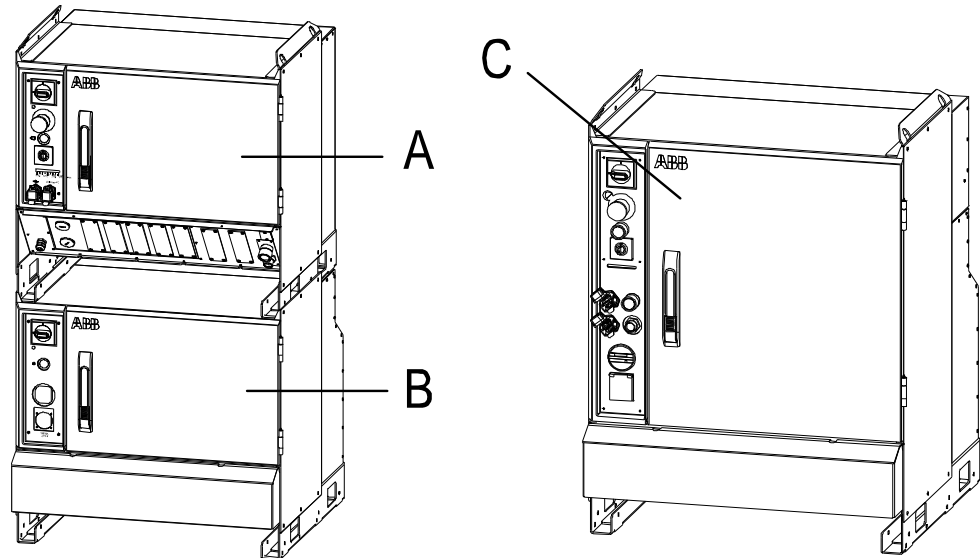

xx0600002929

A	Dual Cabinet (Control Module)
B	Dual Cabinet (Drive Module)
C	Single Cabinet

The Single Cabinet Controller has all components in one single cabinet and the Dual divides the components into two modules: Control Module and Drive Module.

The Single Cabinet Controller is regarded as the standard configuration and therefore the illustration in the procedures detailed in this manual are based on the Single Cabinet Controller.

If the procedure in general is the same, it is mentioned in each procedure where the part is located in the Dual Cabinet configuration. If there are significant differences, both cabinet configurations are shown.



NOTE!

When replacing a unit in the controller, report to ABB:

- the serial number
- article number
- revision

of both the replaced unit and the replacement unit.

This is particularly important for the safety equipment to maintain the safety integrity of the installation.

2 Installation and Commissioning, IRC5

2.2. Installation Activities

2.2. Installation Activities

Preconditions

The following section details the main steps on how to unload, transport, install and connect the IRC5 Controller modules.

Procedure

	Action	Info/Illustration
1.	Unpack the delivered IRC5 Controller.	How to lift,unpack and transport the IRC5 controller is detailed in section Lifting the controller modules on page 39 and Unpacking the controller on page 40
2.	Install the IRC5 Controller.	How to install the IRC5 controller is detailed in section Bolting down the controller on page 43
3.	Connect the manipulator to IRC5 Controller.	How to connect the manipulator to IRC5 controller is detailed in section Connecting the manipulator to the IRC5 controller on page 67.
4.	Connect power supply to the IRC5 Controller.	How to connect power supply is detailed in sections, Connecting power supply to the Single Cabinet Controller on page 57. Connecting power supply to the Dual Cabinet Controller on page 61.
5.	Connect the FlexPendant to the IRC5 Controller.	How to connect the FlexPendant is detailed in section Connecting a FlexPendant on page 52.
6.	Miscellaneous connections.	How to connect MOTORS ON/MOTORS OFF circuits is detailed in section The MOTORS ON/MOTORS OFF circuit on page 69. How to connect to an external safety relay is detailed in Connection of external safety relay on page 74. How to connect buses e.g DeviceNet, is detailed in the Application manual for the bus respectively. How to connect I/O units to the IRC5 controller is detailed in the Application manual for the I/O unit respectively. How to connect to a network is detailed in section Connecting a PC to the service port on page 53.
7.	If used, install add-ons.	How to install add-ons is detailed in section Installation of add-ons on page 106

© Copyright 2004-2010 ABB. All rights reserved.

2.3 Transporting and handling

2.3.1. Lifting the controller modules

Lifting device

Use the two lifting eyes or a fork lift when lifting the IRC5 controller, as shown below. The figure below shows the maximum angle between the lifting straps when lifting the controller. The weight of the controller modules are detailed in section *Unpacking the controller on page 40*

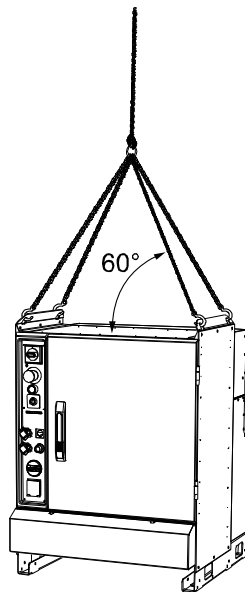

xx0200000076

2 Installation and Commissioning, IRC5

2.3.2. Unpacking the controller

2.3.2. Unpacking the controller

General

Before unpacking and installing the robot system, read the safety regulations and other instructions very carefully. These are found in Chapter *Safety on page 13*.

The installation must be done by qualified installation personnel and should conform to all national and local codes.

When unpacking the controller, check that it was not damaged during transport.



NOTE!

If the IRC5 Controller is going to be stored before unpacking and installation, read the following information regarding storage conditions.

Storage conditions

The table below shows the recommended storage conditions for the IRC5 Controller:

Parameter	Value
Min. ambient temperature	-25 C
Max. ambient temperature	+55 C
Max. ambient temperature (short periods, max 24 h)	+70 C
Max. ambient humidity	Max. 95% at constant temperature

After storage, the operation conditions must be met for at least 4 hours before switching on the controller (see operating conditions below).

Operating conditions

The table below shows the allowed operating conditions for the IRC5 Controller:

Parameter	Value
Min. ambient temperature	0 C
Max. ambient temperature	+45 C
Max. ambient temperature (option)	+52 C
Max. ambient humidity	Max. 95%

Weight controller

The table below shows the weight for the IRC5 Controller:

Controller	Weight
Single Cabinet Controller	max. 150 kg
Dual Cabinet Controller	max. 180 kg
• Control Module	50 kg
• Drive Module	100-130 kg

Protection class

The table below shows the protection classes for the IRC5 Controller and FlexPendant:

Equipment	Protection class
IRC5 Single or Dual Cabinet Controller electronics	IP54
IRC5 Single or Dual Cabinet Controller air cooling ducts	IP33
FlexPendant	IP54

2 Installation and Commissioning, IRC5

2.4.1. Required installation space, IRC5 Controller

2.4 On-site Installation

2.4.1. Required installation space, IRC5 Controller

Dimensions

The figure below shows the required installation space for the IRC5 controller, the illustration shows a Single Cabinet Controller. The measures are the same for the Dual Cabinet Controller.

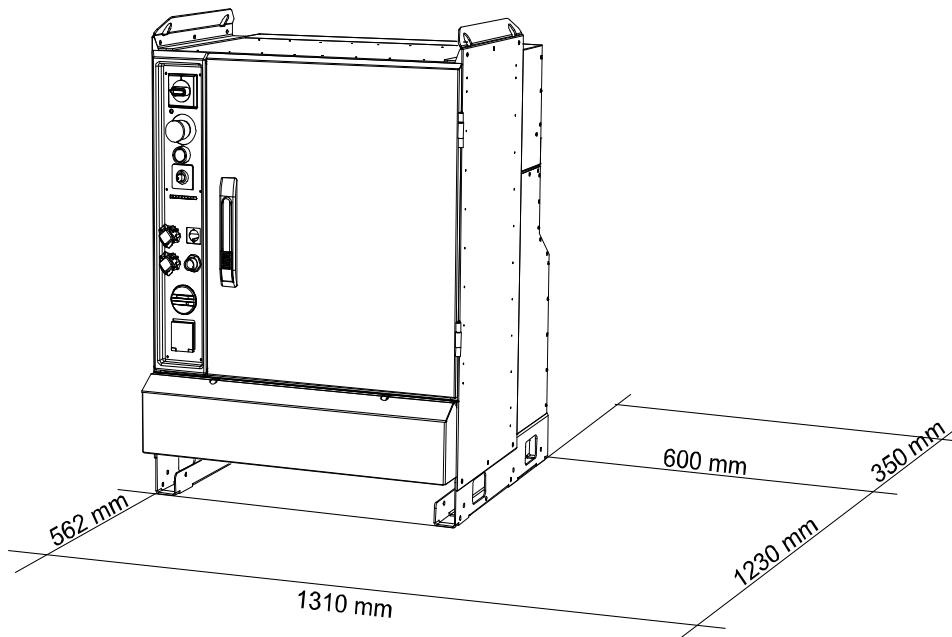

xx0500001848

NOTE! The free space on the right hand side of the controller is required to allow opening the door a full 180° and to access the optional moist dust filter.

NOTE! The air distance 300 mm on the backside of the controller is required to allow inspection and replacement of the optional moist dust filter and ensure proper cooling.

NOTE! Do not place customer cables over the moist dust filters on the backside of the controller. Makes difficult to inspect and replace the moist dust filters.

2.4.2. Bolting down the controller

Bolt pattern, Single Cabinet Controller and Dual Cabinet Controller Design 2006

The figure below shows the bolt pattern for the Single Cabinet Controller:

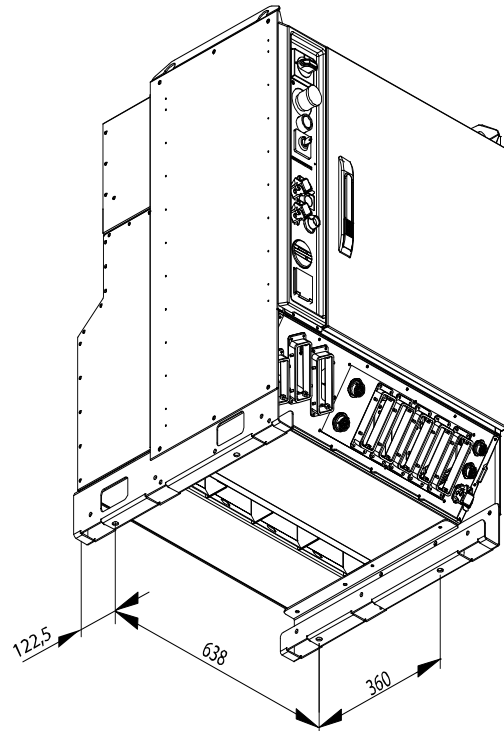

xx0500001853

Bolt pattern, Dual Cabinet Controller Design 2004

The figures below shows the bolt pattern for the Control Module and the Drive Module.

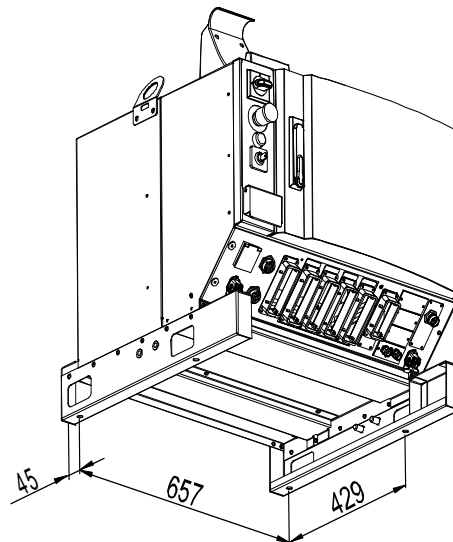

xx0200000075

2.4.3. Transportation screws

General

During transportation the kick cover is secured with two screws. The two screws must be removed before removal of the plate and connection of cables. The screws are located as shown in the illustration below.

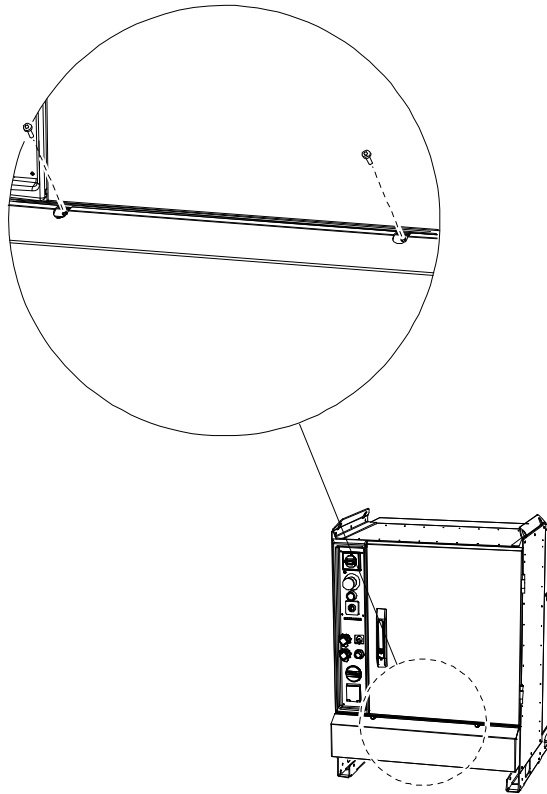

xx0500002038

2.4.4. Mounting the FlexPendant holder

Location

The placement of the FlexPendant holder is shown in the illustration below.

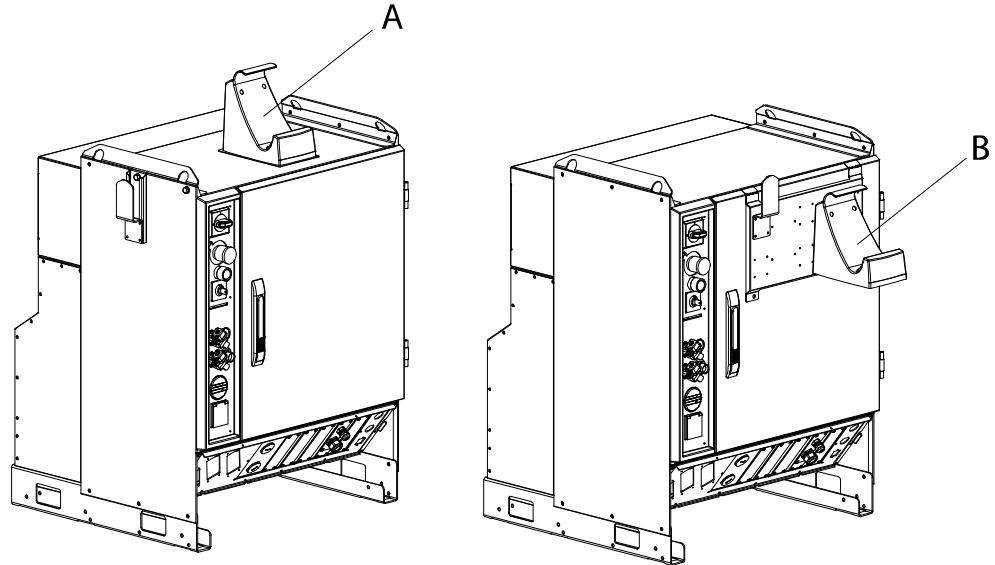

xx0500002542

A	FlexPendant holder mounted on top of the control cabinet.
B	FlexPendant holder mounted on the control cabinet door.



NOTE!

In order to avoid drop of the FlexPendant from high levels, the location of the FlexPendant holder on top of the control cabinet is recommended only with one single cabinet. Otherwise according to location on the control cabinet door.

Required equipment

Equipment	Art.no	Note
Standard tool kit		The contents are defined in section, Standard Toolkit .
FlexPendant holder	3HAC033610-001	



2 Installation and Commissioning, IRC5

2.4.4. Mounting the FlexPendant holder

Continued

Procedure - On top of the control cabinet

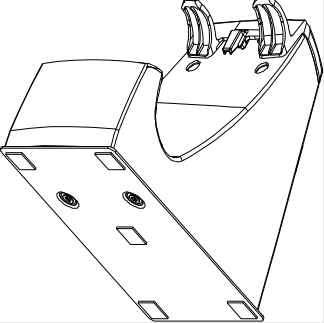
The following procedure details how to mount the FlexPendant holder on top of the control cabinet.

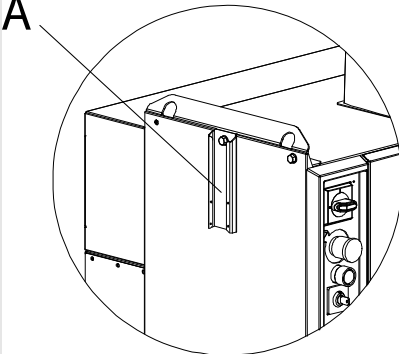
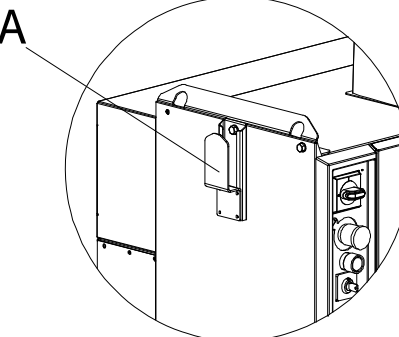
	Action	Note/illustration
1.	Remove the protective liner from the tape.	 xx0500002546
2.	Press the mounting plate with FlexPendant holder against the top of the control cabinet.  NOTE! The surface must be clean and dry.	
3.	Mount the cable bracket holder on the side of the cabinet. Use one of the existing M8 screws.	 xx0700000240 • A: Cable bracket holder
4.	Mount the cable bracket on the cable bracket holder using enclosed Fastite screws (4 pcs).	 xx0700000241 • A: Cable bracket

© Copyright 2004-2010 ABB. All rights reserved.

Continues on next page

Continued

Procedure - On the control cabinet door

The following procedure details how to mount the FlexPendant holder on the control cabinet door.

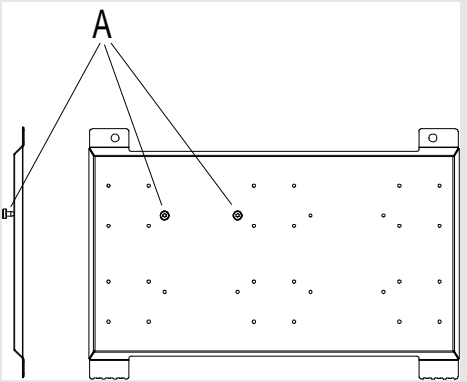
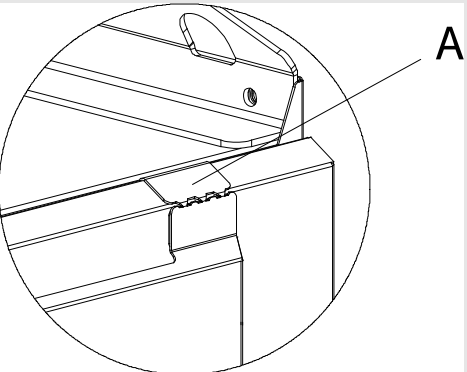
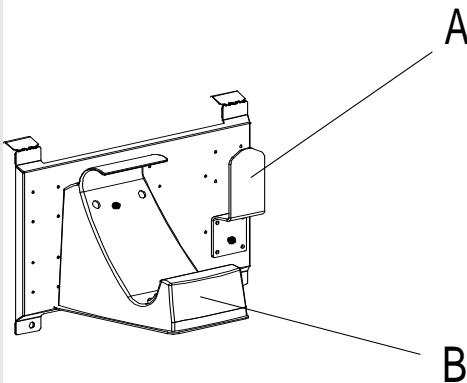
	Action	Note/Illustration
1.	At assembly of FlexPendant holder on the mounting plate start with fasten the Fastite screws (2 pcs) to the mounting plate.	 <p>xx080000048</p> <ul style="list-style-type: none"> • A: Fastite screw (2 pcs)
2.	Bend the two flanges on the mounting plate to match the upper shape of the door.	 <p>xx0700000242</p> <ul style="list-style-type: none"> • A: Flange
3.	Mount the FlexPendant holder and cable bracket to the mounting plate with the enclosed Fastite screws (6 pcs).	 <p>xx0700000244</p> <ul style="list-style-type: none"> • A: Cable bracket • B: FlexPendant holder
4.	Remove the protective liner from the tape on the mounting plate.	

Continues on next page

2 Installation and Commissioning, IRC5

2.4.4. Mounting the FlexPendant holder

Continued

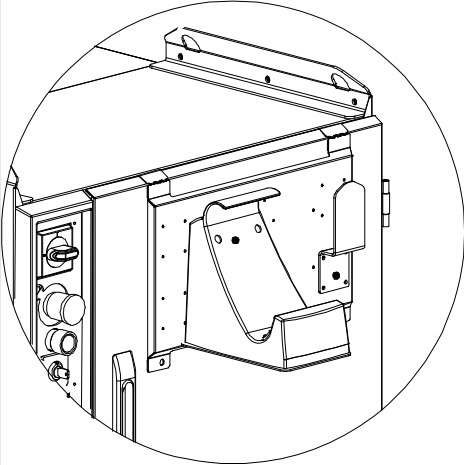
Action	Note/Illustration
<p>5. Press the mounting plate against the control cabinet door.</p> <p></p> <p>NOTE! The surface must be clean and dry.</p>	 <p>xx0700000243</p>

2.5 Connections

2.5.1. Connectors on controller, IRC5

General

The following section describes the connectors on respective front panels on the IRC5 controller. These are described below.

Single Cabinet Controller

The following details the connection interface on the Single Cabinet Controller.

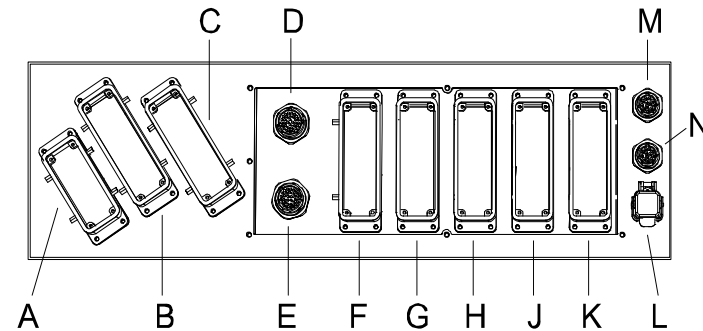

	Description
A	XP.0 Mains connection
B	XS.1 Robot power connection
C	XS.7 Additional axes power connection
D	XS.58 Position switches
E	XS.8 Position switches
F	XS.13/XS.5 Customer power/signals external connection
G	XS.10 Customer options
H	XS.11 Customer options
J	XS.12 Customer options
K	X3 Customer safety signals
L	XS.28 Network connection
M	XS.41 Additional axes SMB connection
N	XS.2 Robot SMB connection

2 Installation and Commissioning, IRC5

2.5.1. Connectors on controller, IRC5

Continued

Dual Cabinet Controller

The following details the connectors on the frontpanel of the Dual Cabinet Controller, that is the Control Module and the Drive Module.

Control Module

The following details the connectors on the frontpanel of the Control Module.

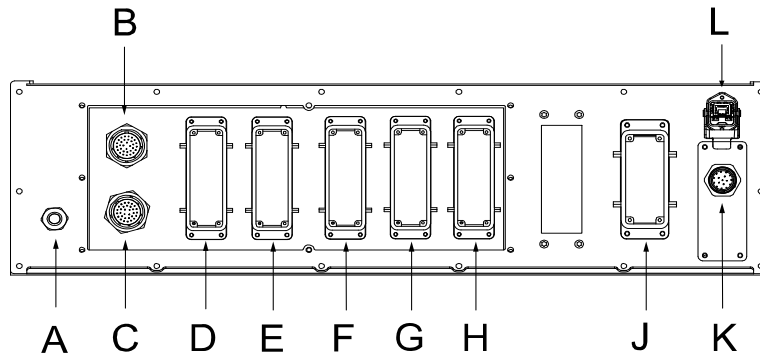

xx040000931

	Description
A	Power connection
B	A5.X8: Position switches
C	A5.X58: Position switches
D	A5.X5: Customer power/signals external connection
E	A5.X11: Customer options
F	A5.X12: Customer options
G	A5.X13: Customer options
H	A5.X14: Customer options
J	A5.X3: Customer safety signals
K	A22.X1: FlexPendant connection
L	A5.X28: Network connection

© Copyright 2004-2010 ABB. All rights reserved.

Continues on next page

Continued

Drive Module

The following details the connectors on the frontpanel of the Drive Module.

Small robots:

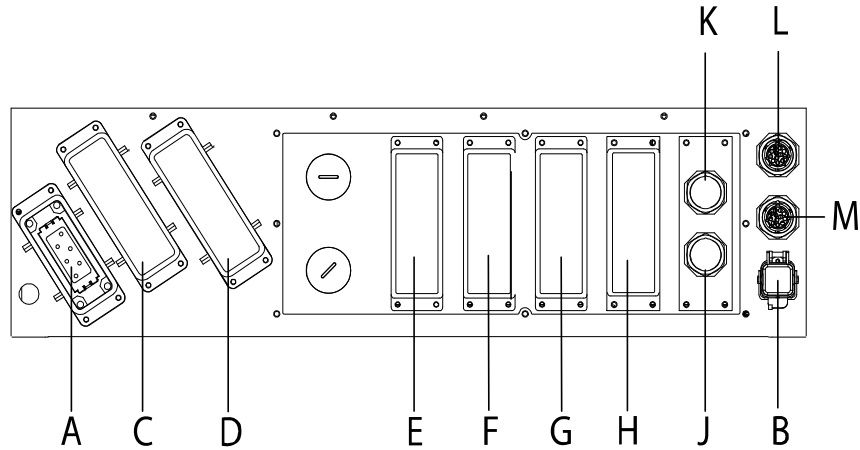

xx0600002931

Large robots:

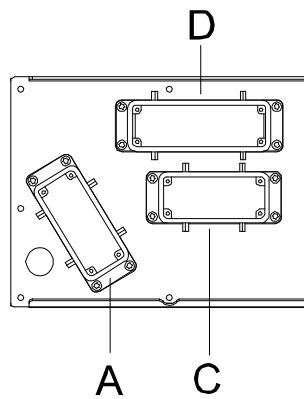

xx0700000424

	Description
A	A4.X0: Mains connection to transformer
B	A4.XS25: Power to Control Module
C	A4.X1: Robot power connection
D	A4.X7: External axes power connection
E	A4.XX: Customer options
F	A4.XX: Customer options
G	A4.XX: Customer options
H	A4.XX: Customer options
J	Communication cabling between Control/Drive Module
K	Communication cabling between Control/Drive Module
L	A4.XS41: Additional axes SMB connection
M	A4.XS2: Robot SMB connection

2 Installation and Commissioning, IRC5

2.5.2. Connecting a FlexPendant

2.5.2. Connecting a FlexPendant

Location of FlexPendant connector

The FlexPendant connector is located on the operator's panel on the controller, or on an external operator's panel. The Panel Mounted Controller has a connector on the front.

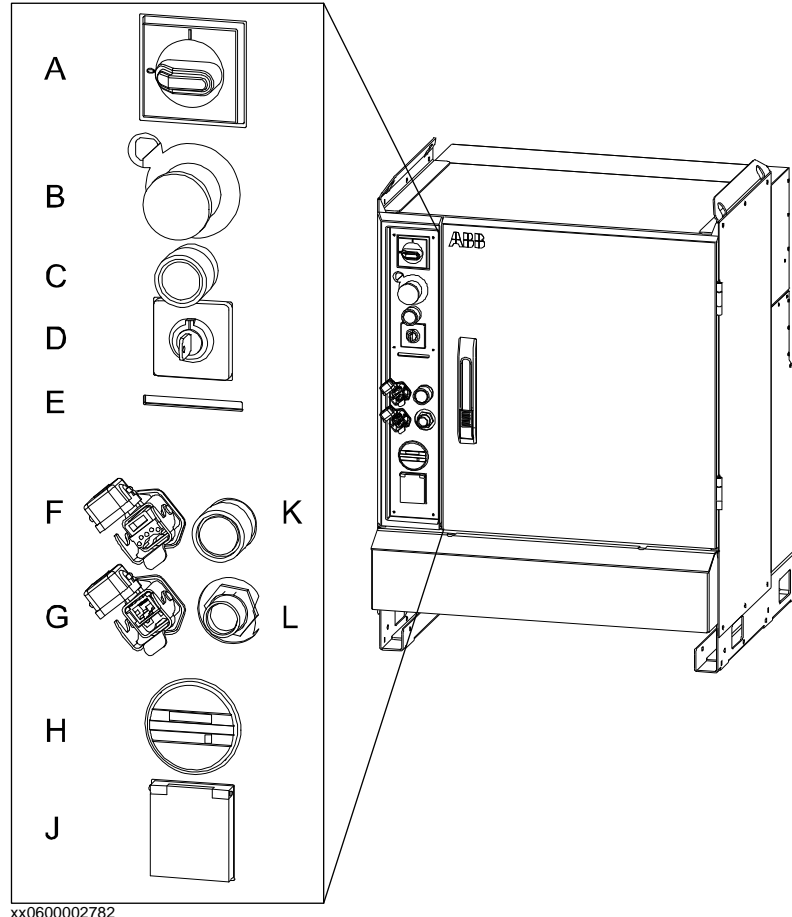

xx0600002782

L FlexPendant connector (A22.X1)

Connecting a FlexPendant

	Action	Info
1.	Locate the FlexPendant socket connector on the controller or operator's panel.	The controller must be in manual mode. If your system has the option Hot plug, then you can also disconnect in auto mode. See section <i>Using the hot plug option</i> in <i>Operating manual - IRC5 with FlexPendant</i> .
2.	Plug in the FlexPendant cable connector.	
3.	Screw the connector lock ring firmly by turning it clockwise.	

© Copyright 2004-2010 ABB. All rights reserved.

2.5.3. Connecting a PC to the service port



NOTE!

The service port shall only be used for direct connection to a PC as described in this procedure. It must not be connected to a LAN (local area network), since it has a DHCP server that automatically distributes IP addresses to all units connected to the LAN.

Contact your network administrator for more information.



NOTE!

The maximum number of connected network clients using robapi is:

- LAN: 3
- Service: 1
- FlexPendant: 1

The total max. number of applications using robapi running on the same PC connected to one controller has no built-in maximum however, UAS limits the number of logged on users to 50.

The total max. number of concurrently connected FTP clients is 4.



CAUTION!

When a cable is connected to the service port on the controller front and the service hatch or the connector cover on the single cabinet is opened, the controller will not comply with the requirements of protection class IP54.

Ports DSQC639

The illustration below shows the two main ports on the computer unit: the Service Port and the LAN port. Make sure the LAN (factory network) is not connected to any of the service ports!

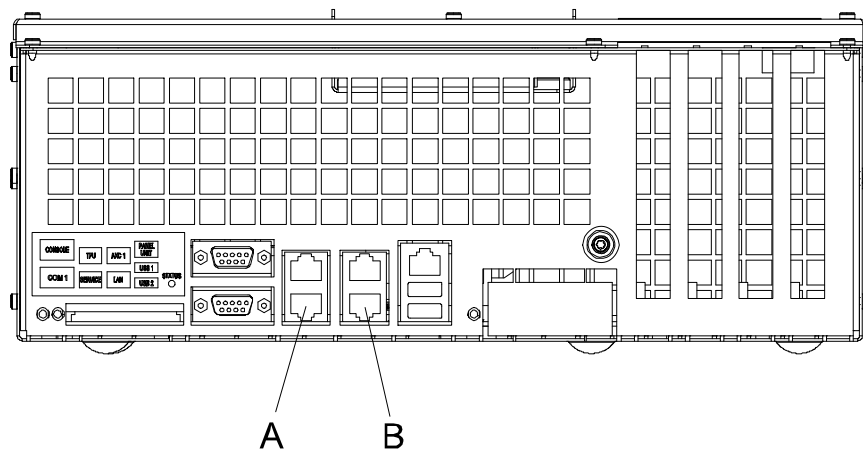

xx0600002889

A	Service port on the computer unit (connected to Service port on the Control Module front through a cable)
B	LAN port on computer unit (connects to factory LAN)

2 Installation and Commissioning, IRC5

2.5.3. Connecting a PC to the service port

Continued

Connections to ports may be done as detailed below.

Connection to/from:	Detailed in section:
Connecting the Single Cabinet/Control Module to the factory LAN.	
Connecting a PC to the Single Cabinet/Control Module service port.	Proceed as detailed below.

Connecting a PC to the service port

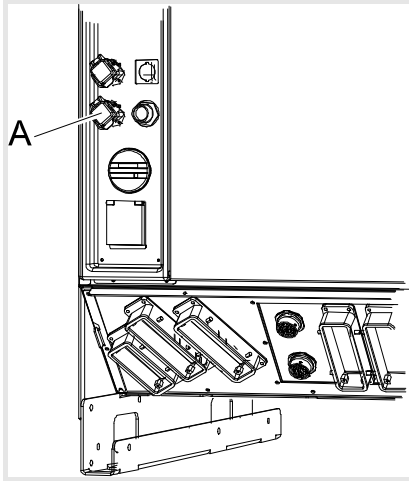
Action	Illustration
1. Make sure the network setting on the PC to be connected is correct.	Refer to the system documentation for your PC, depending on the operative system you are running. The PC must be set to "Obtain an IP address automatically" or set as described in Service PC Information in the Boot Application.
2. Use the delivered category 5 Ethernet crossover boot cable with RJ45 connectors.	The cable is delivered in the RobotWare product box.
3. Connect the boot cable to the network port of your PC.	
4. Connect the boot cable to the service port on the controller.	 <p>xx0600002891</p> <ul style="list-style-type: none"> A: Service port

© Copyright 2004-2010 ABB. All rights reserved.

2.5.4. Connection to serial channel connector

Overview

The controller has one serial channel RS232 for permanent use which can be used for communication point to point with printers, terminals, computers or other equipment.

The following sections describe connection to the serial channel connector (COM1) on the computer unit.

Location DSQC639

The serial channel connector is located on the computer unit as shown below.

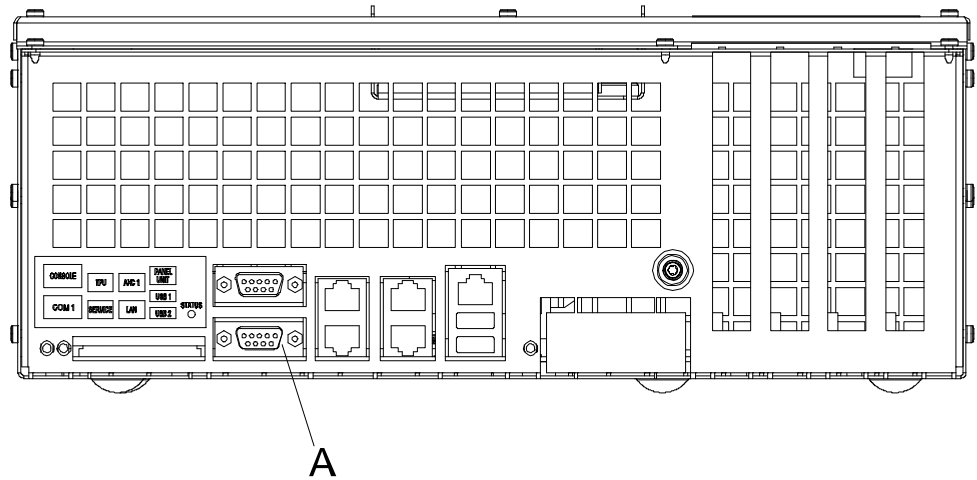

xx0600002892

	Description
A	COM1

Required equipment

Equipment	Note
RS-232/422 converter	DSQC 615 See Computer unit DSQC 639 parts on page 305 for spare part number.
Circuit diagram	See Circuit Diagram on page 319

2 Installation and Commissioning, IRC5

2.5.4. Connection to serial channel connector

Continued

Conversion of the RS232 channel

The RS232 channel can be converted to RS422 full duplex with an optional adapter (Option 714-1).

The RS422 enables a more reliable point to point communication (differential) over longer distances, from RS232 = 15m to RS422 = 120m.

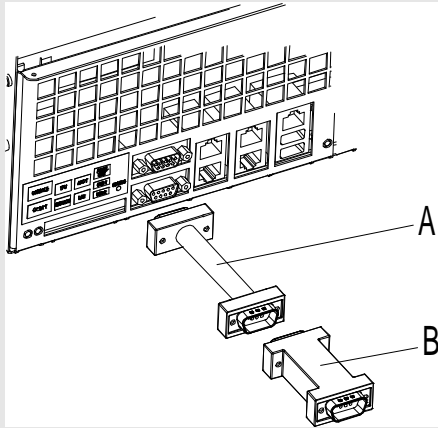
Action	Info/Illustration
1. Connect the adapter to the serial channel connector.	<p>A cable is needed between the serial channel connector and the adapter.</p>  <p>xx0600003075</p> <ul style="list-style-type: none">• A: cable• B: adapter

2.5.5. Connecting power supply to the Single Cabinet Controller

General

The following sections details how to connect power supply to the Single Cabinet Controller.

Location

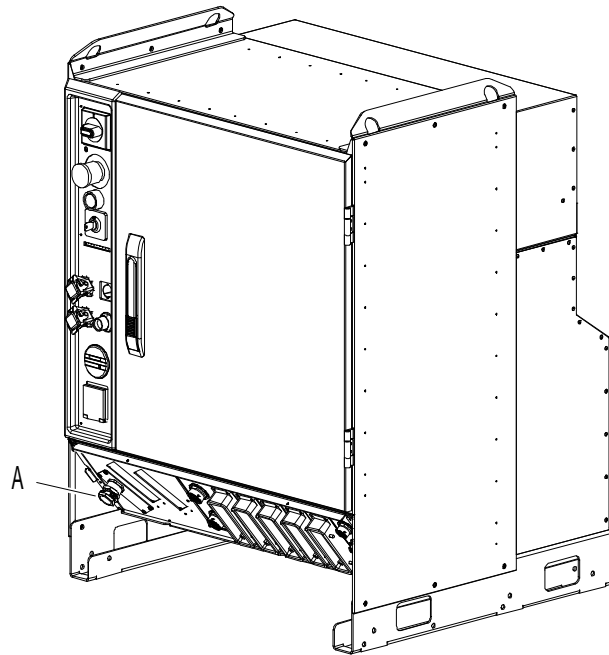

xx0500001869

A Cable gland

Rated voltage and current

To find the rated voltage, rated current and interrupting capacity of the Controller, see the name plate on the side of the cabinet.

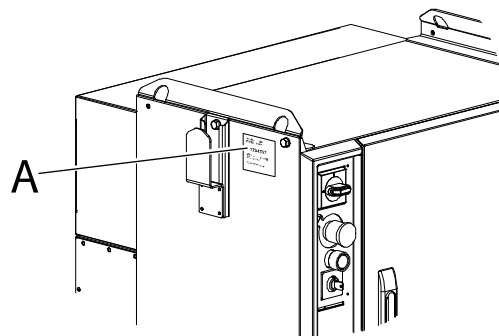

xx0900000273

A Controller name plate

2 Installation and Commissioning, IRC5

2.5.5. Connecting power supply to the Single Cabinet Controller

Continued

Line fusing

Recommended line fusing, slow-blowing diazed or circuit breaker with trip characteristic K.
Max. fuse 35 A, with options 80 A.

Robot	Voltage	Description
IRB 140, 1400, 1600, 2400, 260, 340, 360, 4400, 6400RF	at 400-600 V	3x16 A
IRB 140, 1400, 1600, 2400, 260, 340, 360, 4400, 6400RF	at 200-220 V	3x25 A
IRB 4600, 660, 66XX, 7600	at 400-600 V	3x25 A
IRB 4600, 660, 66XX, 7600	at 200-220 V	3x25 A

Prerequisites

Equipment	Note
Power supply cable (3-phase)	
External earth fault protection (residual current circuit breaker, Class B for frequency converters, 300mA)	For control cables up to 7m, a 30mA earth fault protection can be used if it is Hager CDH440R or equal residual current circuit breaker.
Standard toolkit	The contents are defined in section Standard toolkit!
Other tools and procedures may be required. See references to these procedures in the step-by-step instructions below.	These procedures include references to the tools required.
Circuit Diagram	See Circuit Diagram on page 319

Connection through a cable gland

The following procedures detail how to connect the mains power to the controller through a cable gland.

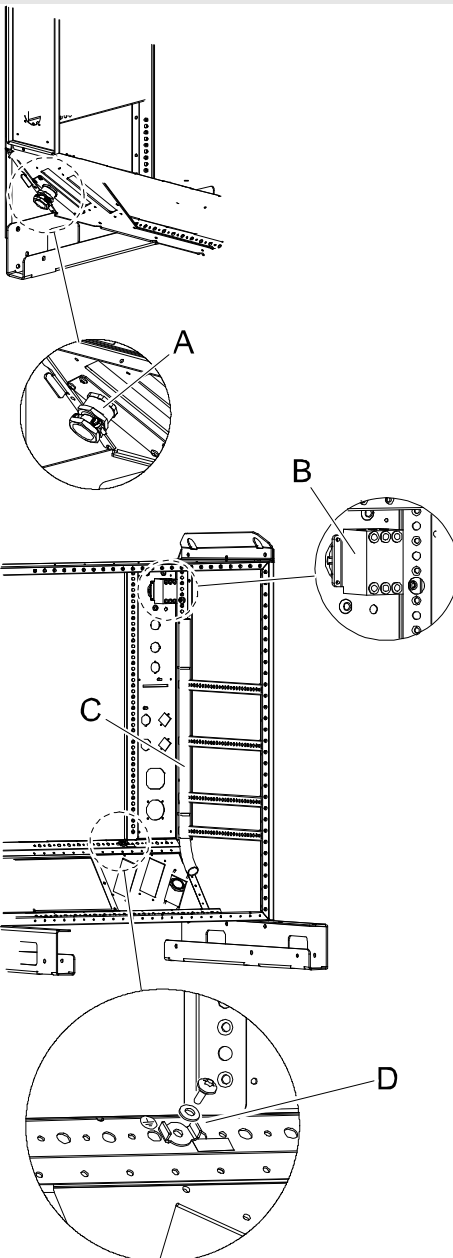
	Action	Note/Illustration
1.	Connect power supply from an external earth fault protection.	Described in section, Prerequisites
	2. Fit the cable trough the cable gland and tighten.	 <p data-bbox="981 1832 1093 1854">xx0500001870</p> <p data-bbox="981 1863 1045 1886">Parts:</p> <ul data-bbox="1013 1899 1252 2024" style="list-style-type: none"> • A: cable gland • B: rotary switch • C: cable pipe • D: grounding point

Continues on next page

2 Installation and Commissioning, IRC5

2.5.5. Connecting power supply to the Single Cabinet Controller

Continued

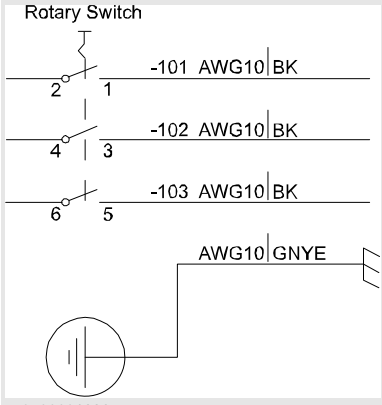
	Action	Note/Illustration
3.	Strip the insulation on the power supply cable long enough to reach the rotary switch.	
4.	Connect the ground cable at the <i>grounding point</i> .	See illustration above. Tightening torque, 4.5Nm.
5.	Route the phase wires through the pipe up to the rotary switch.	See illustration above.
6.	Connect the wires as shown in the illustration.	 <p>Rotary Switch</p> <p>1 -101 AWG10 BK</p> <p>3 -102 AWG10 BK</p> <p>5 -103 AWG10 BK</p> <p>AWG10 GNYE</p> <p>xx0500001882</p>

Connection through a connector

The following procedures detail how to connect the mains power to the controller through a connector.



NOTE!

How to manufacture a cable with connector is described in section [Fitting the connector on page 65](#)

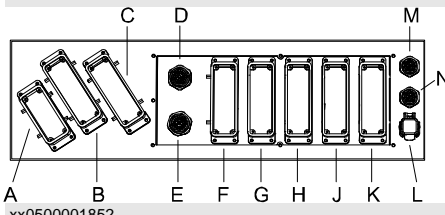
	Action	Note/illustration
1.	Connect the power cable from the shop supply to connector XP0 on the front panel on the controller.	 <p>xx0500001852</p> <p>Parts:</p> <ul style="list-style-type: none"> A: XP0 Mains power connector

© Copyright 2004-2010 ABB. All rights reserved.

2.5.6. Connecting power supply to the Dual Cabinet Controller

General

The following sections details how to connect power supply to the Dual Cabinet Controller for both the Control Module and the Drive Module.

Location

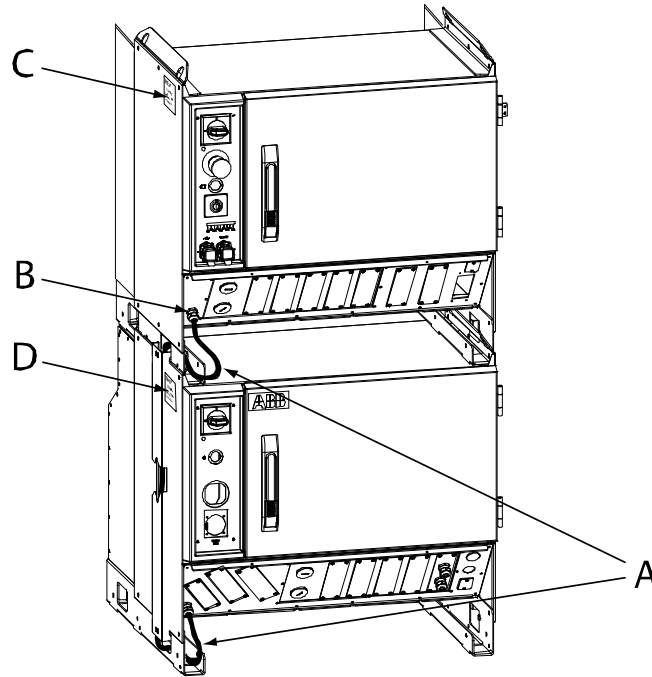

xx0600003364

A	Harness-230V from Drive Module to Control Module.
B	Cable gland for Harness-230V.
C	Name plate for Control Module
D	Name plate for Drive Module

Rated voltage and current

To find the rated voltage, rated current and interrupting capacity of the Control Module and Drive Module, see the name plate on the side of the respective cabinet.

Line fusing

Recommended line fusing, slow-blowing diazed or circuit breaker with trip characteristic K.
Max. fuse 35 A, with options 80 A.

Robot	Voltage	Description
IRB 140, 1400, 1600, 2400, 260, 340, 360, 4400, 6400RF	at 400-600 V	3x16 A
IRB 140, 1400, 1600, 2400, 260, 340, 360, 4400, 6400RF	at 200-220 V	3x25 A
IRB 4600, 660, 66XX, 7600	at 400-600 V	3x25 A
IRB 4600, 660, 66XX, 7600	at 200-220 V	3x25 A

Continues on next page

2 Installation and Commissioning, IRC5

2.5.6. Connecting power supply to the Dual Cabinet Controller

Continued

To Control Module

Normally the 230 V cable between the Drive Module and the Drive Module is connected at delivery.

The following procedure describes exceptions from the standard delivery, when the cable must be connected to the Control Module after delivery.

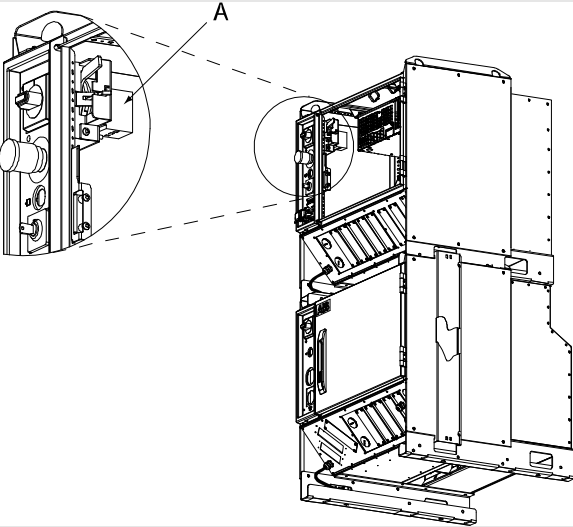
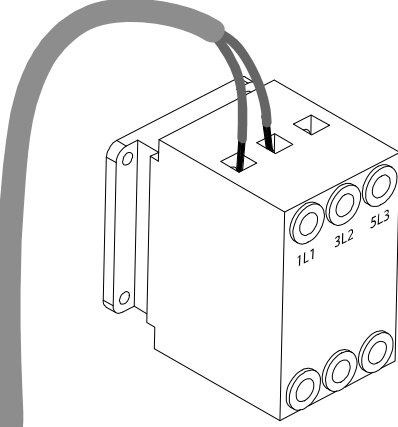
	Action	Note/Illustrator
1.	Lead the harness through the cable gland, into the Control Cabinet.	Connectors on the Control Module are described in section, Connectors on controller, IRC5 on page 49
2.	Loosen the contact behind the main switch of the Control Cabinet.	 <p>xx0600003367 A - Connect</p>
3.	Connect the two power cables from the harness to the contacts marked 1L1 and 3L2 on the contact.	 <p>xx0600003368</p>
4.	Strap the cabling to existing straps inside the module.	

© Copyright 2004-2010 ABB. All rights reserved.

To Drive module

Connecting power to the Drive Module is done exactly as for the Single Cabinet Controller, see [Connecting power supply to the Single Cabinet Controller on page 57](#).

2.5.7. Connecting the communication cabling for the Dual Cabinet Controller

General

Normally the communication cabling between the Control Module and Drive Module are installed at delivery.

The following procedures describes exceptions from the standard delivery, when the cables must be connected to the Control Module after delivery.

Communication cabling

The communication cabling are delivered with the Drive Module, and consists of the following cables:

- Ethernet cable
- Safety cable

Location

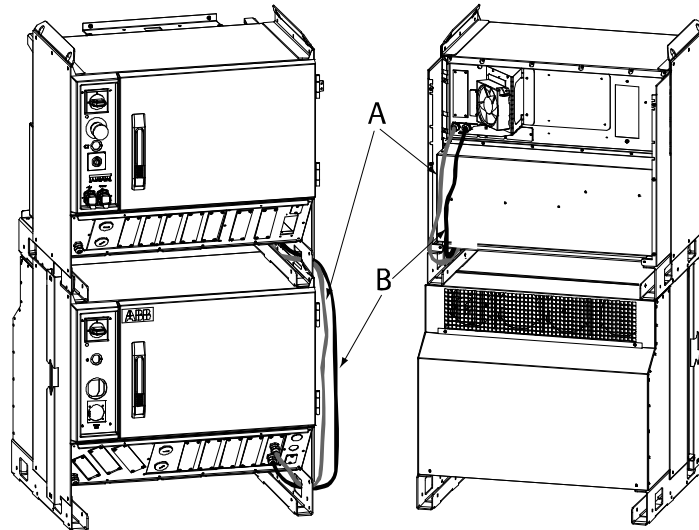

xx0600003365

A	Ethernet cable
B	Safety cable

2 Installation and Commissioning, IRC5

2.5.7. Connecting the communication cabling for the Dual Cabinet Controller

Continued

Procedure

The procedures below details how to install the communication cabling.

The placement of Computer unit, Axis computer, Panel unit and Contactor board are described in the repairs section respectively.

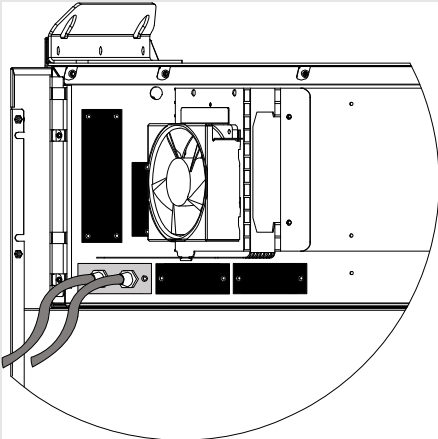
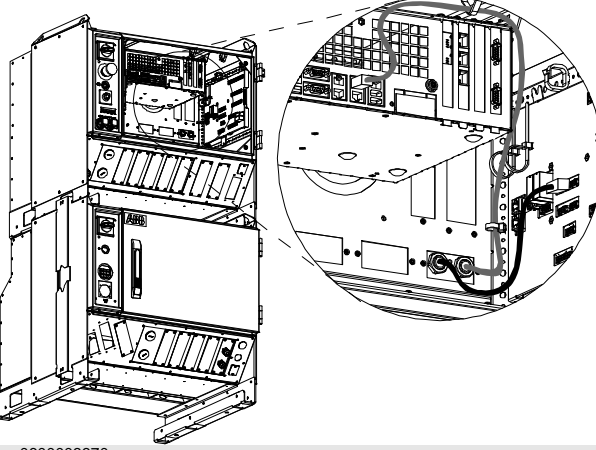
	Action	Info/Illustration
	1. Lead the Ethernet and safety cables from the front of the Drive Module to the back of the Control Module. Lead the cables into the Control Module through the cable glands on the back.	 <p>xx0600003367</p>
	2. Connect the Ethernet cable to the main computer, contact A32.A9. The contact is marked with AXC1. Connect the safety cable to the panel board, contact A21.X7.	 <p>xx0600003370</p>
	3. Strap the cabling to existing straps inside the module.	

© Copyright 2004-2010 ABB. All rights reserved.

2.5.8. Fitting the connector

General

This section describes how to manufacture a cable for connecting the mains power to the Drive Module.

Specifications

The following describes the cable and fuse requirements for the mains power connection to the Drive Module.

Component	Description
Cable type	Flexible oil resistant rubber
Cable area	4 x 6mm ²
Fuse	Delay action fuse 25A

Included parts

The following parts are included in the delivery.

Part	Qty
Female contact	1
Contact housing	1
Brass cable clamp with gasket	1

Procedure

Use the following procedure to fit the connectors.

	Action	Note/Illustration
1.	Select a suitable three phase + earth cable and cut it to desired length.	See specifications above.
2.	Make sure all parts required are available.	Specified in Included parts above.

2 Installation and Commissioning, IRC5

2.5.8. Fitting the connector

Continued

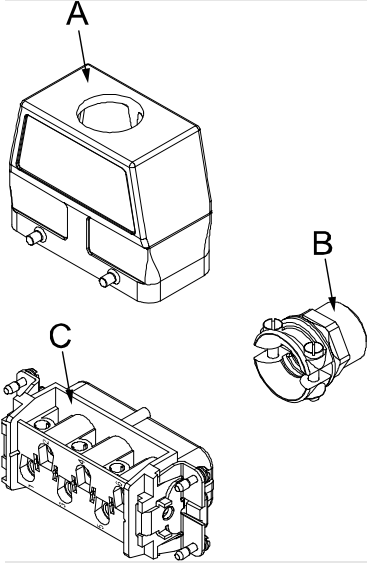
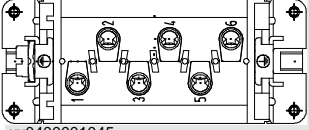
	Action	Note/Illustration
	3. Fit the cable through the housing and the brass cable clamp, and connect the wires to the female connector.	 <p>xx0400001044</p> <ul style="list-style-type: none">• A: housing• B: Brass cable clamp• C: female connector
	4. Connect the wires according to the illustration.	 <p>xx0400001045</p> <ul style="list-style-type: none">• X0.1 - phase 1• X0.2 - phase 2• X0.3 - phase 3• X0.PE - earth wire
	5. Assemble the connector by fitting the housing and the brass cable clamp.	

2.5.9. Connecting the manipulator to the IRC5 controller

General

Connect the manipulator and IRC5 controller to each other after installing them. The lists below specify which cables to be used in each application.

All connectors on the IRC5 controller are shown in section *Connectors on controller, IRC5 on page 49*.

Main cable categories

All cables between manipulator and IRC5 controller are divided into the following categories:

Cable category	Description
Manipulator cables	Handles power supply to and control of the manipulator's motors as well as feedback from the serial measurement board.
Position switch cables (option)	Handles supply to and feedback from any position switches.
Customer cables (option)	Handles communication with equipment fitted on the manipulator by the customer.
Additional axes cables (option)	Handles power supply to and control of the external axes motors as well as feedback from the servo system.

These categories above are divided into sub-categories which are specified in section *Manipulator cables on page 308*.

2.5.10. Connecting safety signals

External customer connection

If the cabinet is equipped with the option External customer connection, connect the connector as shown in the following illustration.

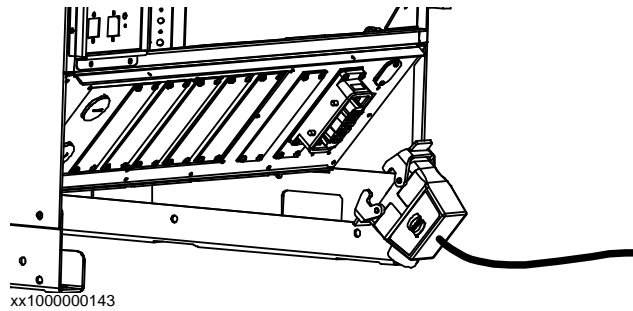

Internal customer connection

If the cabinet is not equipped with the option External customer connection, the signal cables must go through a cable gland and be connected to the Panel board inside the cabinet.

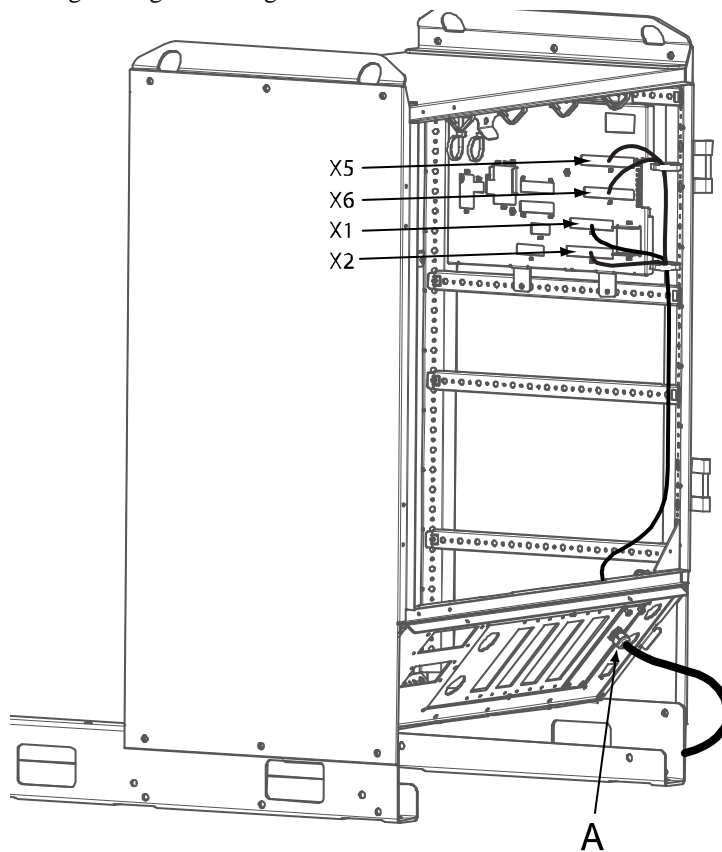

A Cable gland



NOTE!

The signal cable should be shielded and the shielding connected to the cable gland, or a ferrite ring should be used around the cable inside the cabinet close to the cable gland. The same goes for all customer I/O signals.

2.5.11. The MOTORS ON/MOTORS OFF circuit

Outline diagram

The MOTORS ON/MOTORS OFF circuit is made up of two identical chains of switches.

The diagram shows the available customer connections, AS, GS, SS and ES.

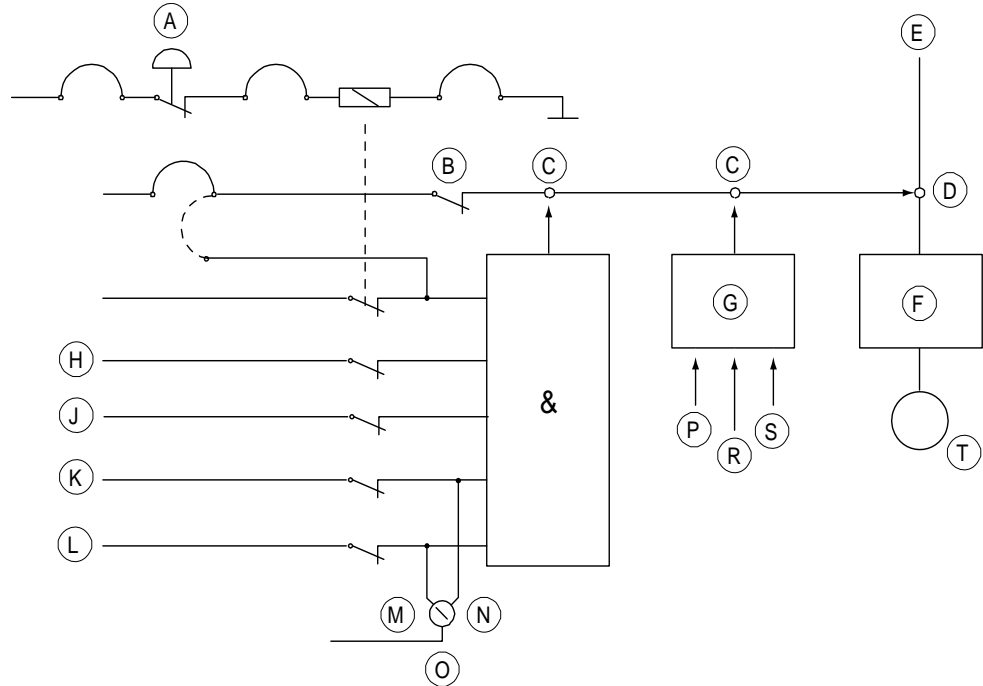

xx0100000174

A	ES (emergency stop)
B	LS (Limit switch)
C	Solid state switches
D	Contactor
E	Mains
F	Drive unit
G	Second chain interlock
H	GS (general mode safeguarded space stop)
J	SS (superior stop, same function as GS)
K	AS (Automatic mode safeguarded space stop)
L	ED (TPU enabling device)
M	Manual mode
N	Automatic mode
O	Operating mode selector
P	RUN
R	EN1
S	EN2
T	Motor

2 Installation and Commissioning, IRC5

2.5.11. The MOTORS ON/MOTORS OFF circuit

Continued

Function of the MOTORS ON/MOTORS OFF circuit

The circuit monitors all safety related equipment and switches. If any of the switches is opened, the MOTORS ON/MOTORS OFF circuit switches the power to the motors off.

As long as the two chains not are in an identical state, the robot will remain in MOTORS OFF mode.

Connection of safety chains

The diagram below shows the dual channel safety chain.

The supply from internal 24V and 0 V is displayed. For external supply of GS and AS check the circuit diagram.

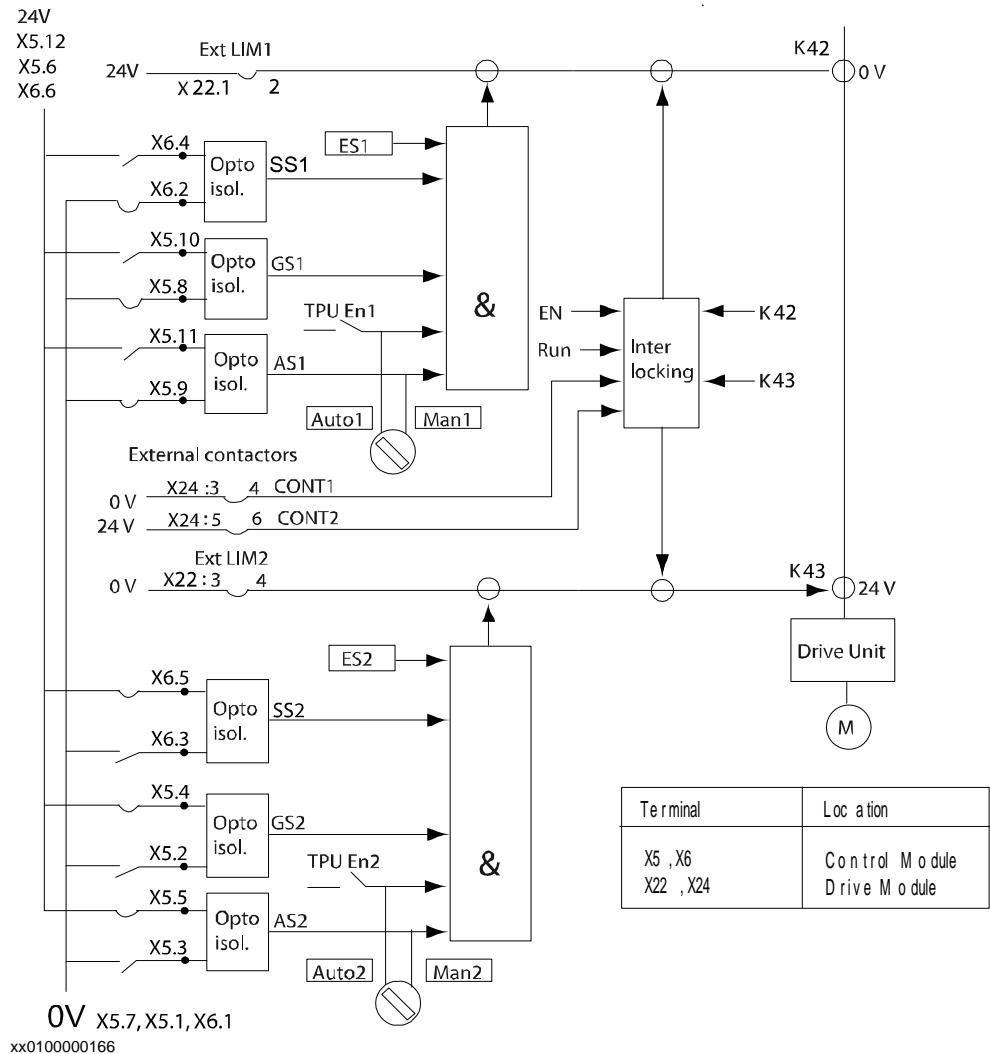

Technical data per chain	
Limit switch	Load: 300 mV Max. voltage drop: 1 V
External connectors	Load: 10 mA Max. voltage drop: 4 V
GS/AS/SS load at 24 V	25 mA
GS/AS/SS closed "1"	>18 V

Continues on next page

Continued

Technical data per chain	
GS/AS/SS open "0"	< 5 V
External supply of GS/AS/SS	Max. + 35 VDC Min. - 35 VDC
GS/AS/SS Filter time	2,0 ms ¹⁾
Max. potential in relation to the cabinet earthing and other signal groups.	300 V
Signal class	Control signals

1) When connecting e.g. a Safety PLC to a safety stop, make sure that the safety check pulses not exceeds 2,0 ms, otherwise a safety relay must be connected in between. See illustration below.

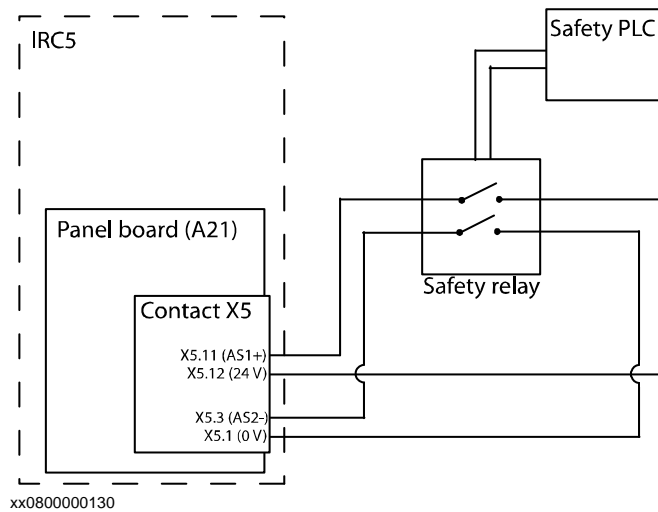

2 Installation and Commissioning, IRC5

2.5.11. The MOTORS ON/MOTORS OFF circuit

Continued

Connection of ES1/ES2 on panel unit

The diagram below shows the terminals for the emergency circuits.

The supply from internal 24V (X1/X2:10) and 0V (X1/X2:10) is displayed. For an ext. supply, X1:3 / X2:9 is connected to ext. 24V, and X1:9 / X2:3 is connected to ext. 0V (dotted lines).

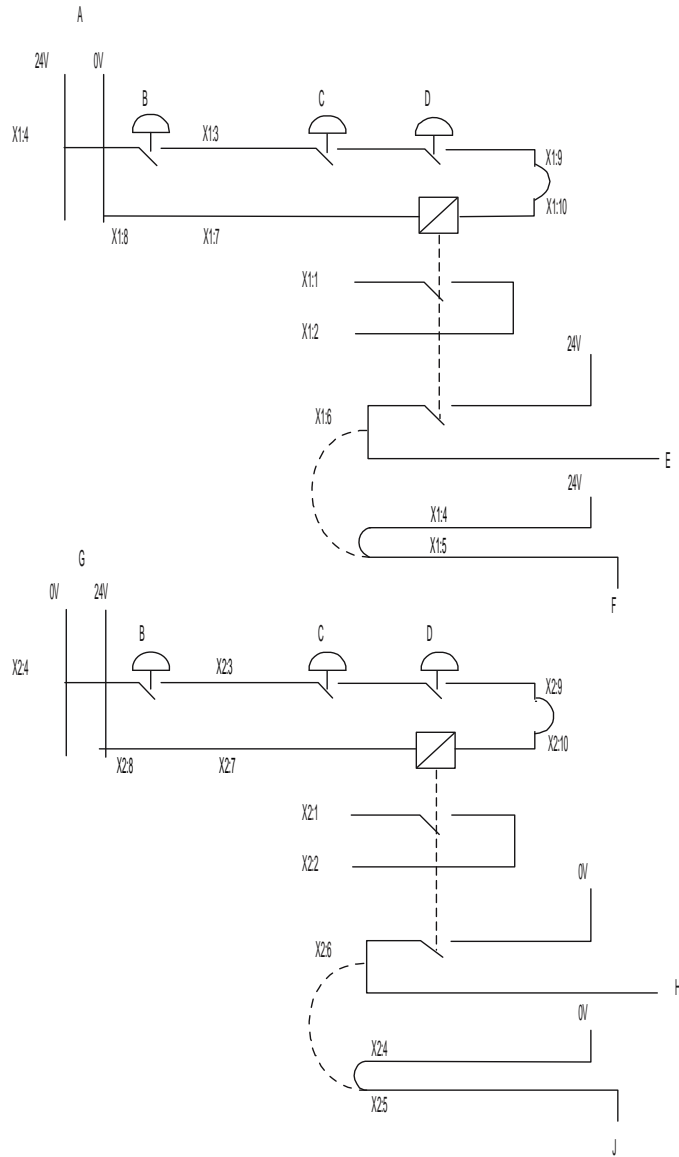

xx0100000191

A	Internal
B	Ext stop
C	FlexPendant
D	Cabinet
E	ES1 internal
F	Run chain 1 top
G	Internal
H	ES2 internal
J	Run chain 2 top

Continues on next page

© Copyright 2004-2010 ABB. All rights reserved.

Continued

Technical data	
ES1 and ES2 max output voltage	120 VAC or 48 VDC
ES1 and ES2 max output current	120 VAC: 4 A 48 VDC L/R: 50 mA 24 VDC L/R: 2 A 24 VDC R load: 8 A
External supply of ES relay	24 VDC \pm 10% between terminals X1:9, 8 and X2:9, 8 respectively. Note! In case of interference, the external supply must be properly filtered.
Rated current per chain	40 mA
Max. potential in relation to the cabinet earthing and other signal groups.	300 V
Signal class	Control signals

Connection to operating mode selector (Option)

The illustration below shows the connection of terminals for customer use.

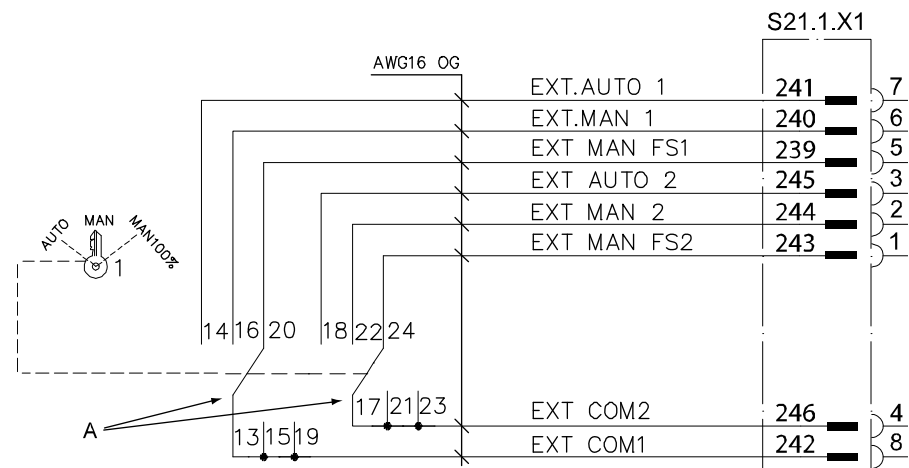

xx0500002092

A Mode selector

External manual FS (Full Speed) 100% is an option.

Technical data	
Max. voltage	48 VDC
Max. current	4 A
Max. potential in relation to the cabinet earthing and other signal groups.	300 V
Signal class	Control signals

2.5.12. Connection of external safety relay

Description

The motor contactors K42 and K43 in the Drive Module can operate with external equipment if external relays are used.

The following figure shows an example of how to connect an external safety relay.

Connection example

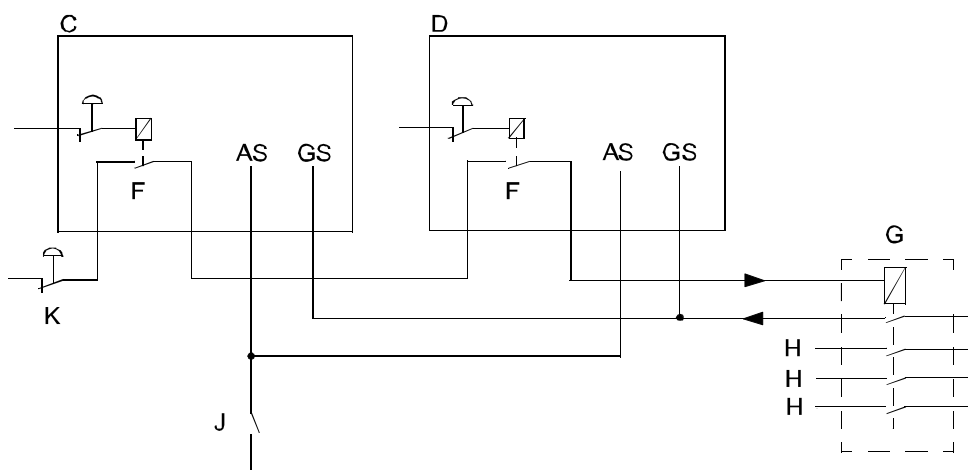

xx0100000246

C	Robot 1
D	Robot 2
F	ES (emergency stop) relay
G	External Safety relay
H	To other equipment
J	Safety gate
K	Cell ES (emergency stop)

2.5.13. Connection to MOTORS ON/MOTORS OFF contactor

General

This section details connection to the MOTORS ON/MOTORS OFF contactor. To be used when the customer wants external equipment to follow the robot control.

Location

The MOTORS ON/MOTORS OFF contactor is located on the left hand side in the Drive Module.

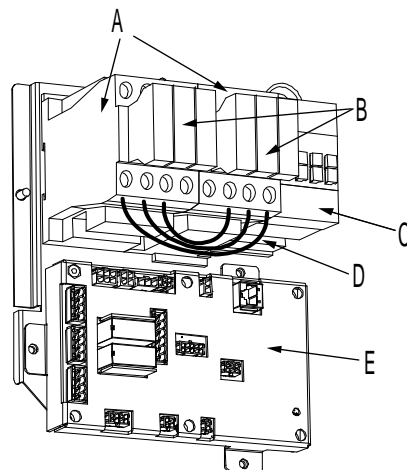

xx0400001058

A	MOTOR ON contactor K42 / K43
B	Contactor auxiliary block 33-34
C	Brake contactor
D	Jumper (3 pcs)
E	Contactor interface board

Required equipment

The table below details the required equipment.

Equipment	Note
Standard toolkit	
Circuit Diagram	See Circuit Diagram on page 319

Technical data

The table below shows technical data.

Technical data	
Max. voltage	48 VDC
Max. current	4 A
Max. potential in relation to the cabinet earthing and other signal groups.	300 V
Signal class	Control signals

Continues on next page

2 Installation and Commissioning, IRC5

2.5.13. Connection to MOTORS ON/MOTORS OFF contactor

Continued

Procedure

Following procedure describes connection to the MOTORS ON/MOTORS OFF contactor.

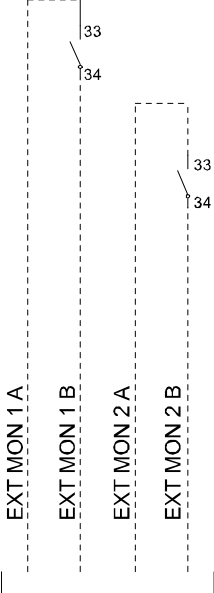
	Action	Info/Illustration
1.	 DANGER! Before commencing any work inside the cabinet, please observe the safety information in section <i>DANGER - Make sure that the main power has been switched off!</i> on page 30.	
2.	Connect the wires to the contactor auxiliary blocks 33-34, according to the diagram to the right.	 <p>The diagram shows four terminal blocks labeled EXT MON 1 A, EXT MON 1 B, EXT MON 2 A, and EXT MON 2 B. Each block has two terminals, 33 and 34. Dashed lines indicate the following connections: EXT MON 1 A (33) to EXT MON 1 B (34), EXT MON 1 A (34) to EXT MON 2 A (33), EXT MON 1 B (33) to EXT MON 2 B (34), and EXT MON 1 B (34) to EXT MON 2 B (33).</p> <p>xx0400001231</p>

2.5.14. Connection of Drive Module Disconnect, by limit switch

General

This function enables you to temporarily disconnect a Drive Module and deactivate any robot or additional mechanical units connected to this module. The procedures are detailed below. It is also possible to connect a remote switch to enable a Drive Module Disconnect. The required equipment and procedure for connection of a switch are specified below.



NOTE!

The system diagnostics monitors the connection and disconnection of Drive Modules, and event log messages regarding these events will be stored in the event log when required. These messages are accessible using the FlexPendant or RobotStudio.

Location

The contactor interface board unit is located on the left hand side of the controller as shown below.

In the Dual Cabinet Controller, the board is located in the Drive Module.

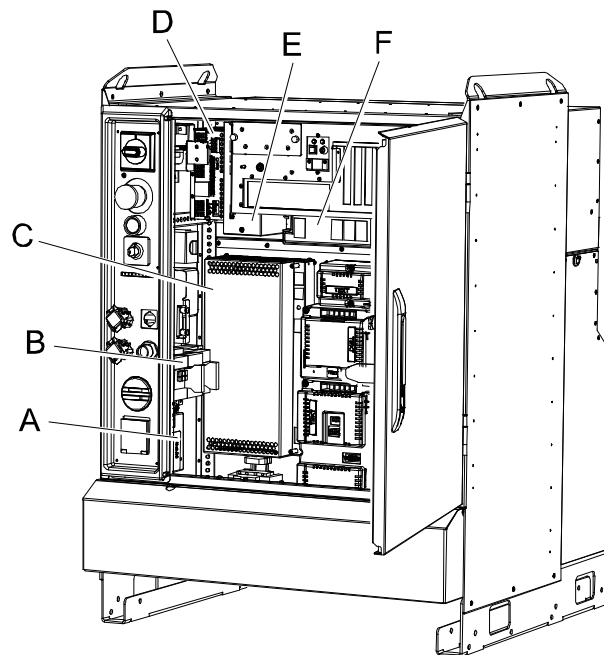

xx0500001951

A	Contactor interface board
B	Contactors
C	Drive system power supply
D	Customer I/O power supply
E	Control power supply
F	Backup energy bank

2 Installation and Commissioning, IRC5

2.5.14. Connection of Drive Module Disconnect, by limit switch

Continued

Required equipment

The table below details the required equipment.

Equipment	Note
Wire	AWG20
Switch	24V 0,5A
Operating manual - RobotStudio	
Operating manual - IRC5 with FlexPendant	
Standard toolkit	
Circuit diagram	See Circuit Diagram on page 319

Enabling a Drive Module Disconnect in RobotStudio

The following procedures details how to enabeling the system for a Drive Module Disconnect.

Action
1. In RobotStudio, select the Topic: Motion .
2. Select Type: Drive Module User Data .
3. Set the parameter for selected drive module to YES .
4. Restart the system. (Warm start)

Enabling a Drive Module Disconnect with the FlexPendant

The following procedures details how to enabeling the system for a Drive Module Disconnect.

Action
1. On the FlexPendant, Tap ABB and then Tap Control Panel .
2. In the Control panel menu, Tap Configuration .
3. In the Configuration menu, Tap Topics , and select Motion .
4. In the Topic: Motion , Tap Type: Drive Module User Data .
5. Tap selected drive module.
6. Tap the parameter in order to modify it.
7. Restart the system (warm start).

© Copyright 2004-2010 ABB. All rights reserved.

Continues on next page

Disconnect the Drive Module

The following procedure details how to disconnect a Drive Module.

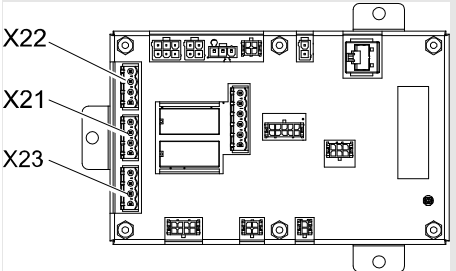
	Action	Note/illustration
1.	Make sure that the system is in the MOTORS_OFF state.	
2.	Disconnect the connector X22.	<p>It is also possible to use connector X21, but this is typically used for limit switches on the robot.</p>  <p style="text-align: right; font-size: small;">xx</p>

Reconnect the Drive Module

The following procedure details how to reconnect the Drive Module.

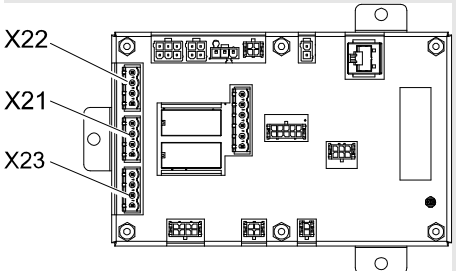
	Action	Note/illustration
1.	Make sure that the system is in the MOTORS_OFF state.	
2.	Reconnect the X22 connector.	 <p style="text-align: right; font-size: small;">xx0500002087</p>
3.	Move the program pointer to main in the RAPID-program where the disconnected mechanical units are active.	

Connect a remote switch

The following procedures details how to connect a remote switch.

	Action	Note/illustration
1.	Make sure that the system is in the MOTORS_OFF state.	
2.	Disconnect the jumpers from the connector X22.	

2 Installation and Commissioning, IRC5

2.5.14. Connection of Drive Module Disconnect, by limit switch

Continued

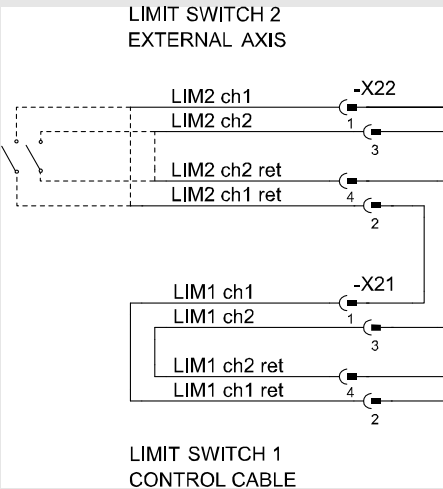
	Action	Note/illustration
	3. Connect the wires to the connector X22 according to the diagram on the right.	 <p>LIMIT SWITCH 2 EXTERNAL AXIS</p> <p>LIMIT SWITCH 1 CONTROL CABLE</p> <p>xx0500002091</p>

2.5.15. Connection of servo disconnect, by servo power switch

General

The IRC5 controller is pre-wired to accept a customer servo disconnect.



NOTE!

Due to risk of voltage drop, the switch to the servo disconnect circuit should not be mounted more than 50 meters from the Drive Module.

Location

The contactor is found on the left hand side inside the Drive Module as shown below.

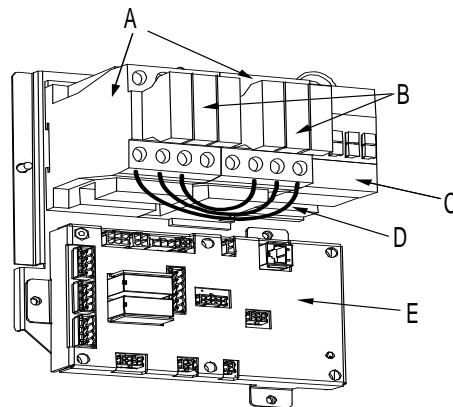

xx0400001058

A	MOTOR ON contactor K42 / K43
B	Contactor block3
C	Brake contactor
D	Jumper (4 pcs)
E	Contactor interface board

Required equipment

The table below details the required equipment.

Equipment	Note
Wire	AWG 10, brake AWG 16
Switch	500V 40 A, brake 24V 10A
Standard toolkit	
Circuit Diagram	See Circuit Diagram on page 319



WARNING!

It is recommended to also open the 24V to the brake (wire 489) to avoid accidental release of the brakes when the drive system is disconnected.

2 Installation and Commissioning, IRC5

2.5.15. Connection of servo disconnect, by servo power switch

Continued

Procedure

Following procedure details how to connect a servo disconnect.

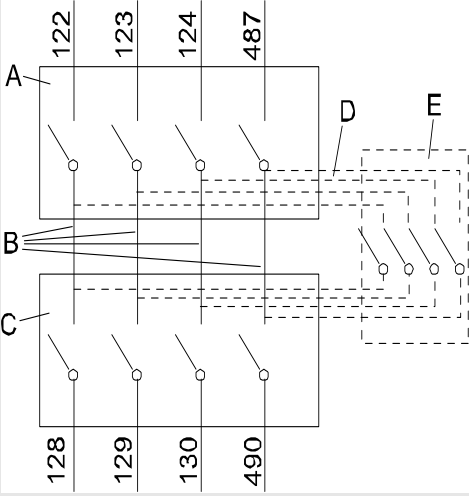
	Action	Note/Illustration
1.	 DANGER! Before commencing any work inside the cabinet, please observe the safety information in section <i>DANGER - Make sure that the main power has been switched off!</i> on page 30.	
2.	Remove the four jumpers between contactors R2 and R3	The jumpers are shown in Location on page 81
3.	Connect the wires according to the diagram on the right.	 <p>xx040000</p> <ul style="list-style-type: none">• A: MOTOR ON contactor K43• B: Jumper (4 pcs)• C: MOTOR ON contactor K42• D: Wires to external main switch• E: External switch

2.5.16. Connecting a Limit switch override push button



DANGER!

The Limit switch override is used to disconnect safety limitations. Make sure the Limit switch override function is not active longer than absolutely necessary.

If the option SafeMove is implemented, Limit switch override must never be used at all. The SafeMove safety controller has its own override function.

General

The override circuit enables the possibility to jog an axis out of a forbidden (limited) zone.

Limitations

The switch has to be placed inside the controller to eliminate the risk of electrical noise.

Required equipment

Equipment	Art. no	Note
Contact block	1SFA 610 605 R1001	ABB CW Control
Contact blocks with holder	1SFA 611 605 R1201	ABB CW Control
Push button (in Dual Cabinet)	1SFA 611 102 R1105	ABB CW Control
Connector X23	1SSA 245 204 R0100	ABB CW Control
Wire		Cable AWG 20 Blue
Standard toolkit		Described in section, Standard Toolkit .
Circuit diagram		See Circuit Diagram on page 319

Procedure for Single Cabinet Controller

The following procedure details how to connect a Limit switch override circuit in a Single Cabinet Controller.

Action	Note/illustration
1.  Danger DANGER! Before any work inside the IRC5 controller modules, please observe the safety information in section DANGER - Make sure that the main power has been switched off! on page 30 .	

2 Installation and Commissioning, IRC5

2.5.16. Connecting a Limit switch override push button

Continued

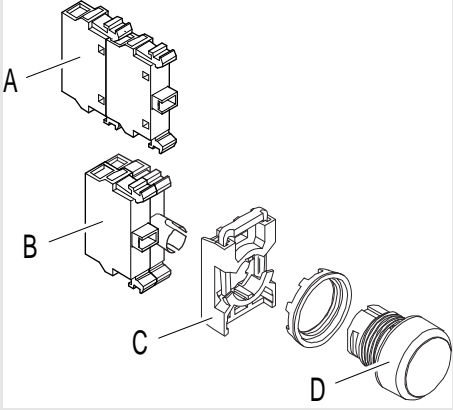
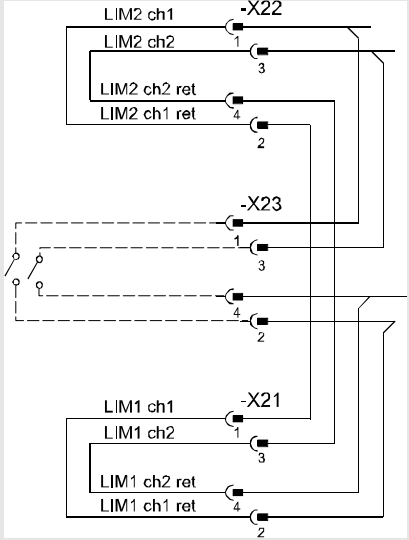
Action	Note/illustration
<p>2. Attach two additional contact blocks on the existing push button (Motors on).</p> <div data-bbox="472 421 544 495" style="text-align: center;">  </div> <p style="text-align: center;">note</p> <p>Note! There is only room for one additional contact block beside the two existing. Therefore, place one additional block on top of the other.</p>	<div data-bbox="943 360 1398 768" style="text-align: center;">  </div> <p style="text-align: center;">xx0500002553</p> <ul style="list-style-type: none"> • A: Additional contact blocks • B: Existing contact, lamp blocks • C: Holder • D: Push button
<p>3. Connect wires from the contact blocks to the connector according to the diagram to the right.</p>	<div data-bbox="943 969 1353 1507" style="text-align: center;">  </div> <p style="text-align: center;">xx0500002556</p>

© Copyright 2004-2010 ABB. All rights reserved.

Continues on next page

Continued

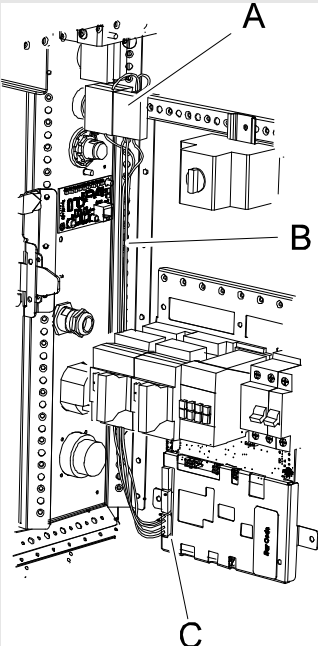
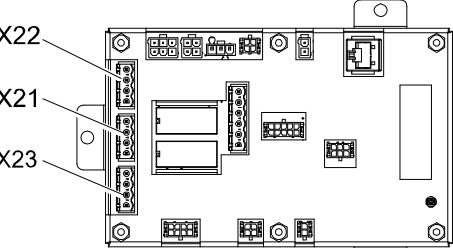
Action	Note/illustration
<p>4. Route the wires together with the existing harness on the left wall.</p>	 <p>xx0500002557</p> <ul style="list-style-type: none"> • A: Contact blocks • B: Wires • C: Connector X23
<p>5. Fit the connector to the X23 connector on the contactor interface board.</p>	 <p>xx0500002087</p>

2 Installation and Commissioning, IRC5

2.5.16. Connecting a Limit switch override push button

Continued

Procedure for Dual Cabinet Controller

The following procedure details how to connect a Limit switch override circuit in a Dual Cabinet Controller.

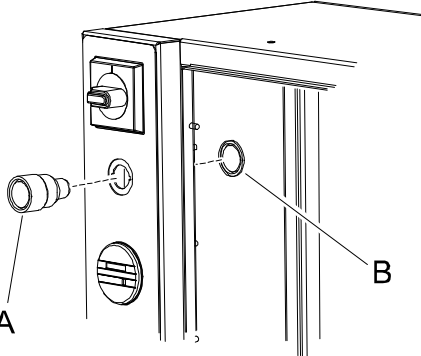
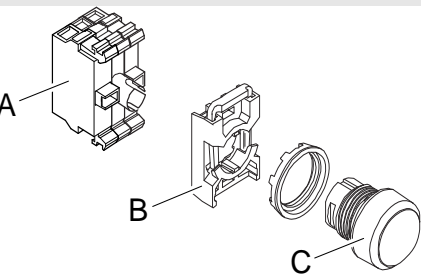
Action	Note/illustration
<p>1.</p>  <p>Danger</p> <p>DANGER!</p> <p>Before any work inside the IRC5 controller modules, please observe the safety information in section <i>DANGER - Make sure that the main power has been switched off!</i> on page 30.</p>	
<p>2. Disconnect the two wires from the signal lamp block.</p>	
<p>3. Remove the signal lamp from the operator's panel on the Drive Module.</p>	 <p>xx0500002563</p> <ul style="list-style-type: none"> • A: Signal lamp • B: Attachment nut
<p>4. Fit the push button with holder and contact and lamp blocks in the existing hole of the signal lamp.</p>	 <p>xx0500002554</p> <ul style="list-style-type: none"> • A: Contact, lamp blocks • B: Holder • C: Push button
<p>5. Reconnect the two wires from signal lamp to the new lamp block.</p>	

© Copyright 2004-2010 ABB. All rights reserved.

Continues on next page

Continued

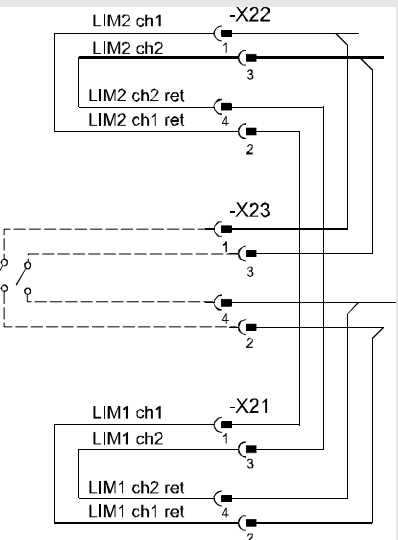
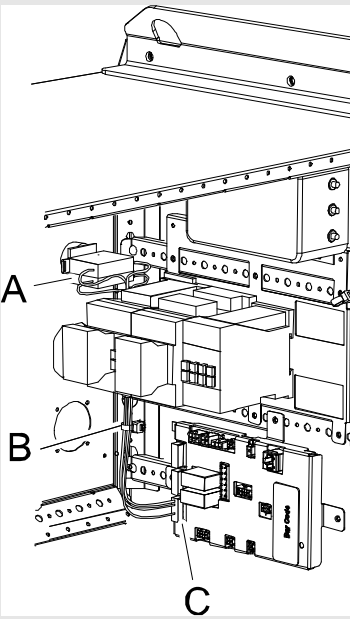
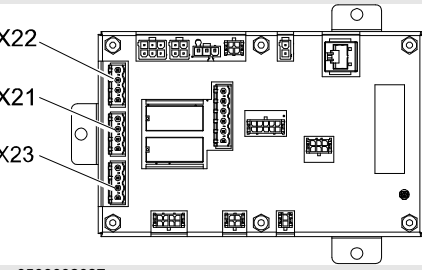
Action	Note/illustration
<p>6. Connect wires from the contact blocks to the connector according to the diagram to the right.</p>	 <p style="text-align: right;">xx050000</p>
<p>7. Route the wires together with the existing harness on the left wall.</p>	 <p style="text-align: right;">xx0500002564</p> <ul style="list-style-type: none"> • A: Contact block • B: Wires • C: Connector X23
<p>8. Fit the connector to the X23 connector on the contactor interface board.</p>	 <p style="text-align: right;">xx0500002087</p>

2 Installation and Commissioning, IRC5

2.6.1. Drive functions, general

2.6 Drive system

2.6.1. Drive functions, general

General

The robot is powered by power electronics found in the IRC5 controller, (for the Dual Cabinet Controller it's found in the Drive Module). This also includes power electronics for driving additional axes.

Standard configurations

The drive system is available in different sizes depending on which robot to drive and other power requirements.

How to configure the drive system is described in section *Configuration of Drive System 04, IRC5 on page 91* or *Configuration of Drive System 09, IRC5 on page 98*.

Install drive system parts

How to install the drive system parts is described in section *Installation of Drive system parts (Drive System 04) on page 114* or *Installation of Drive system parts (Drive System 09) on page 116*.

2.6.2. Drive System 04 or 09?

Overview

The IRC5 Controller is delivered with either Drive System 04 or Drive System 09. Their function is the same, but for maintenance and when connecting additional axes it is necessary to know which drive system the controller has.

Drive System 04

In Drive System 04 it is easy to see one drive unit for each robot axis. The axis computer used with Drive System 04 is slightly larger than the one for Drive System 09.

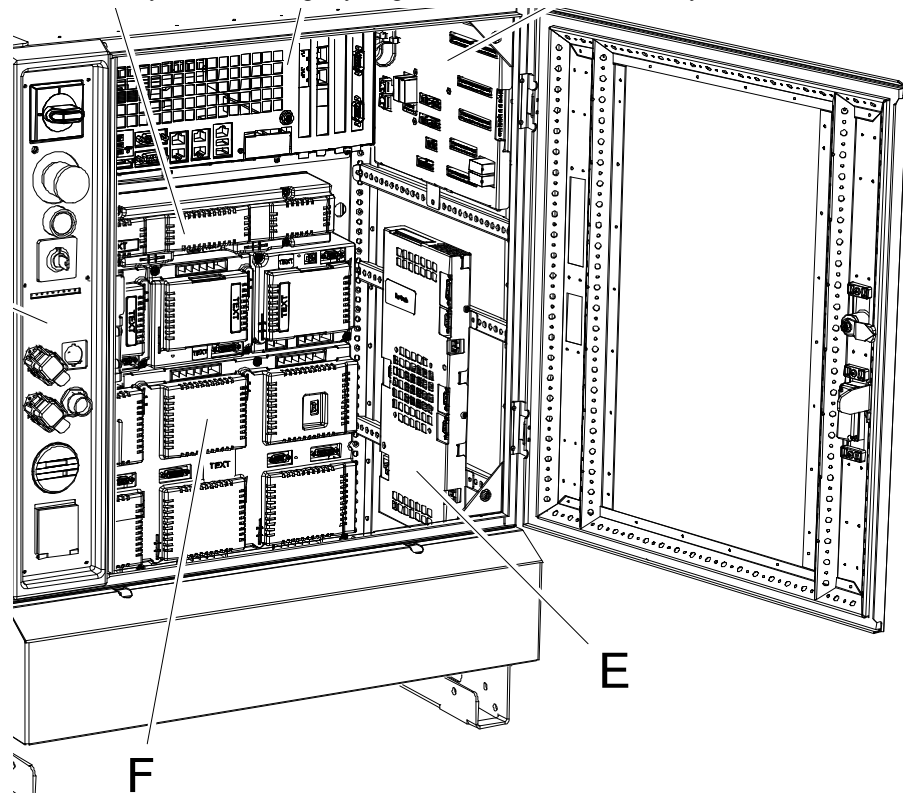

xx0500001858

E	Axis computer
F	Drive system

2 Installation and Commissioning, IRC5

2.6.2. Drive System 04 or 09?

Continued

Drive System 09

In Drive system 09 there is only one unit including rectifier, capacitors and drive units for all robot axes, the Main Drive Unit. The axis computer used with Drive System 09 is slightly smaller than the one for Drive System 04.

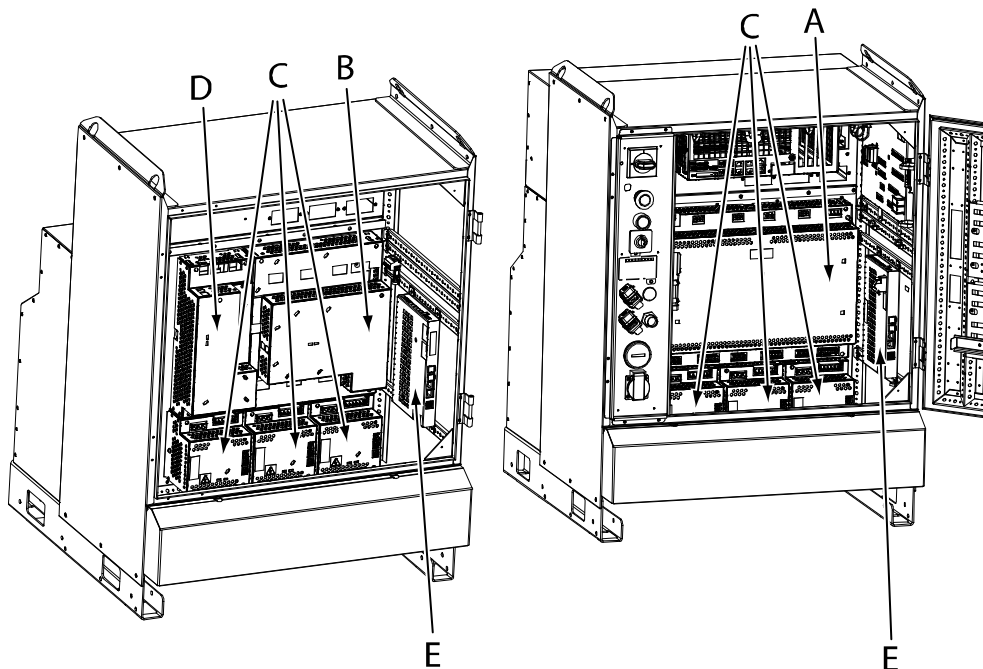

xx100000001

A	Main Drive Unit for large robots
B	Main Drive Unit for small robots
C	Additional Drive Units (for additional axes)
D	Additional Rectifier Unit (only used for additional axes in combination with small robots)
E	Axis computer

2.6.3. Configuration of Drive System 04, IRC5

General

The IRC5 Single Cabinet Controller contains a number of drive units, rectifiers and filters. Any allowed combination of these, depending on the robot type, is specified below.

The robot system may also be equipped with up to three additional drive modules, which are described in section *Installation of additional Drive Module on page 106*.

Location

The servo drive units, rectifiers and capacitor units are located in the Single Cabinet Controller as shown below.

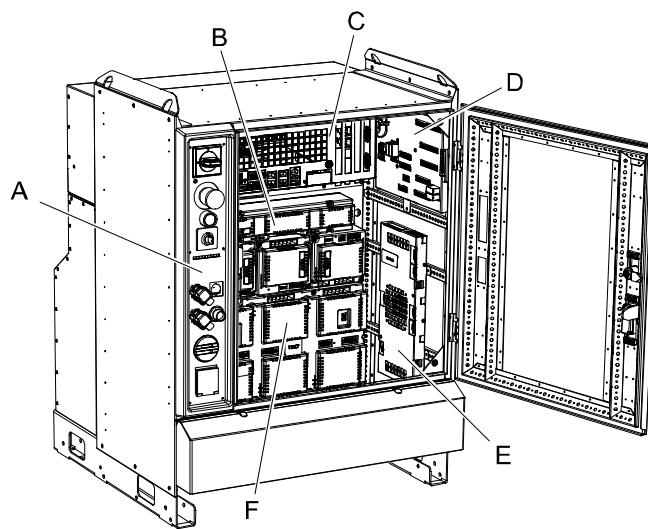

xx0500001858

	Description
A	Operator's panel
B	Capacitor
C	Computer unit
D	Panel unit
E	Axis computer
F	Drive system, (drive units and rectifier)

DC busbars

Between the units are fitted DC-busbars, which are specified below:

Description	Art. no.	Note
DC-bus bar	3HAC17281-1	DC_L6: long busbar with six connector groups
DC-bus bar	3HAC17281-3	DC_S2: short busbar with two connector groups
Servo drive dummy	3HAC17282-1	-

Continues on next page

2 Installation and Commissioning, IRC5

2.6.3. Configuration of Drive System 04, IRC5

Continued

IRB 140

The figures show the drive unit with and without additional axes respectively. The table specifies which units may be fitted in which positions.

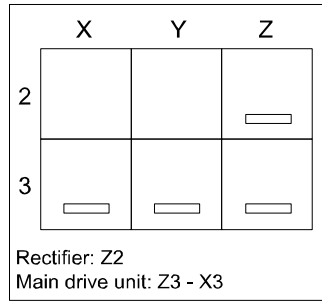

xx0200000121

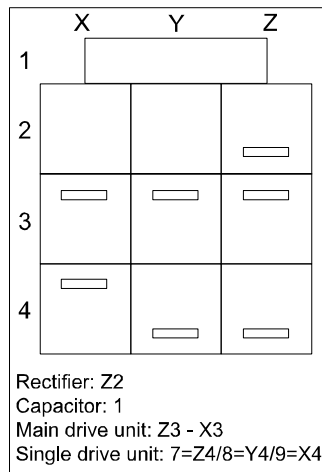

xx0200000120

Pos.	Identification	Description	Art. no.	Note
1	DSQC 620_C2	Capacitor unit	3HAC14551-1	Only in system with two external axes, size U
Z2	DSQC 618_RC1	Rectifier	3HAC14549-1	In systems <i>without</i> external axes only!
Z2	DSQC 618_R2	Rectifier	3HAC14549-2	In systems <i>with</i> external axes only!
Z3, Y3, X3	DSQC 617_3B3A	Main Drive unit	3HAC025338-001	Z3 - X3 is ONE unit!
Z4, Y4, X4	DSQC 619	Optional drive units for additional axes	3HAC14550-1 3HAC14550-2 3HAC14550-3	Size: 1C Size: 1T Size: 1U

© Copyright 2004-2010 ABB. All rights reserved.

Continues on next page

IRB 340, 360

The figures show the drive unit with and without additional axes respectively. The table specifies which units may be fitted in which positions.

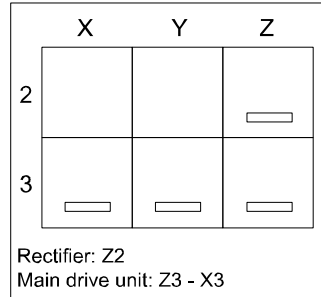

xx0200000121

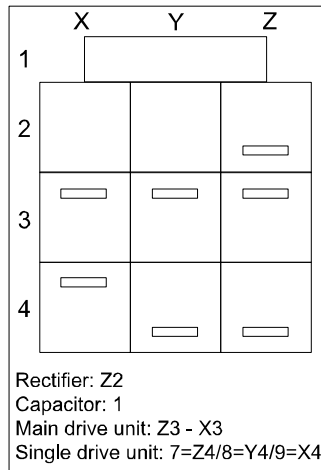

xx0200000120

Pos.	Identification	Description	Art. no.	Note
1	DSQC 620_C2	Capacitor unit	3HAC14551-1	In systems <i>with</i> external axes only!
1	DSQC 620_C4	Capacitor unit	3HAC14551-3	Only in system with two external axes, size U
Z2	DSQC 618_RC1	Rectifier	3HAC14549-1	In systems <i>without</i> external axes only!
Z2	DSQC 618_R2	Rectifier	3HAC14549-2	In systems <i>with</i> external axes only!
Z3, Y3, X3	DSQC 617_3E1C	Main Drive unit	3HAC025338-003	Z3 - X3 is ONE unit!
Z4, Y4, X4	DSQC 619	Optional drive units for additional axes	3HAC14550-1 3HAC14550-2 3HAC14550-3	Size: 1C Size: 1T Size: 1U

Continues on next page

2 Installation and Commissioning, IRC5

2.6.3. Configuration of Drive System 04, IRC5

Continued

IRB 1400

The figures show the drive unit *with and without additional axes* respectively. The table specifies which units may be fitted in which positions.

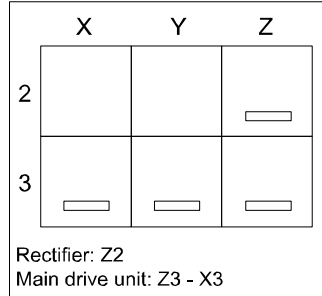

xx0200000121

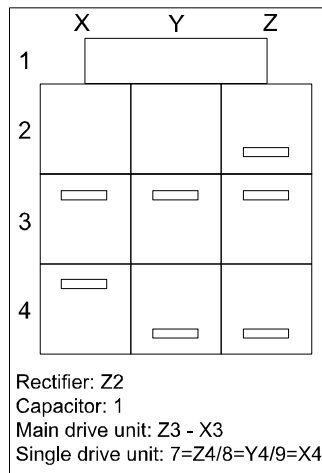

xx0200000120

Pos.	Identification	Description	Art. no.	Note
1	DSQC 620_C4	Capacitor unit	3HAC14551-3	Only in system with two external axes, size U
Z2	DSQC 618_RC1	Rectifier	3HAC14549-1	In systems <i>without</i> external axes only!
Z2	DSQC 618_R2	Rectifier	3HAC14549-2	In systems <i>with</i> external axes only!
Z3, Y3, X3	DSQC 617_3B3A	Main Drive unit	3HAC025338-001	Z3 - X3 is ONE unit!
Z4, Y4, X4	DSQC 619	Optional drive units for additional axes	3HAC14550-1 3HAC14550-2 3HAC14550-3	Size: 1C Size: 1T Size: 1U

© Copyright 2004-2010 ABB. All rights reserved.

Continues on next page

IRB 1600, 2400

The figures show the drive unit with and without additional axes respectively. The table specifies which units may be fitted in which positions.

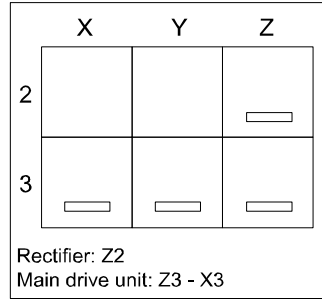

xx0200000121

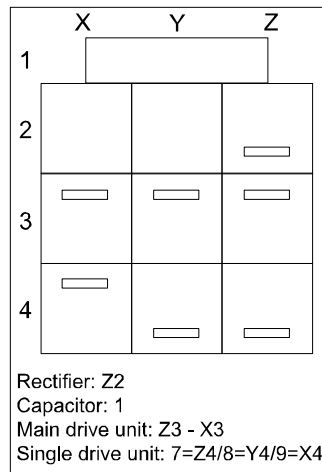

xx0200000120

Pos.	Identification	Description	Art. no.	Note
1	DSQC 620_C4	Capacitor unit	3HAC14551-3	Only in system with two external axes, size U
Z2	DSQC 618_RC1	Rectifier	3HAC14549-1	In systems <i>without</i> external axes only!
Z2	DSQC 618_R2	Rectifier	3HAC14549-2	In systems <i>with</i> external axes only!
Z3, Y3, X3	DSQC 617_2E2C2B	Main Drive unit	3HAC025338-002	Z3 - X3 is ONE unit!
Z4, Y4, X4	DSQC 619	Optional drive units for additional axes	3HAC14550-1 3HAC14550-2 3HAC14550-3	Size: 1C Size: 1T Size: 1U

Continues on next page

2 Installation and Commissioning, IRC5

2.6.3. Configuration of Drive System 04, IRC5

Continued

IRB 4400

The figures show the drive unit with and without additional axes respectively. The table specifies which units may be fitted in which positions.

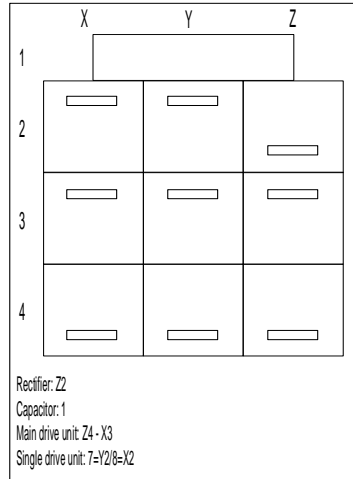

xx030000184

Pos.	Identification	Description	Art. no.	Note
1	DSQC 620_C4	Capacitor unit	3HAC14551-3	
Z2	DSQC 618_R2	Rectifier	3HAC14549-2	
Y2, X2	DSQC 619	Optional drive units for additional axes	3HAC14550-1 3HAC14550-2 3HAC14550-3	Size: 1C Size: 1T Size: 1U
Z4, Y4, X4, Z3, Y3, X3	DSQC 617_3G3T	Main Drive unit	3HAC025338-004	Z4 - X3 is ONE unit!

IRB 6400RF

The figures show the drive unit with and without additional axes respectively. The table specifies which units may be fitted in which positions.

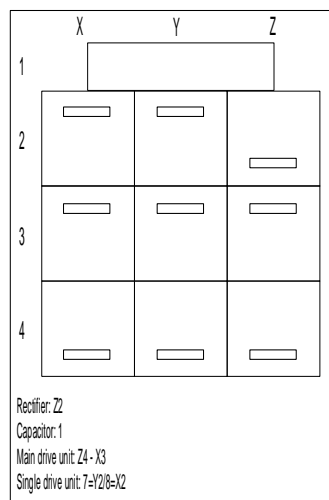

xx030000184

© Copyright 2004-2010 ABB. All rights reserved.

Continues on next page

Continued

Pos.	Identification	Description	Art. no.	Note
1	DSQC 620_C4	Capacitor unit	3HAC14551-3	
Z2	DSQC 618_R2	Rectifier	3HAC14549-2	
Y2, X2	DSQC 619	Optional drive units for external axes	3HAC14550-4	Size: 1W
Z4, Y4, X4, Z3, Y3, X3	DSQC 617_3V3W	Main Drive unit	3HAC025338-006	Z4 - X3 is ONE unit!

IRB 4600, 6600, 7600

The figures show the drive unit with and without additional axes respectively. The table specifies which units may be fitted in which positions.

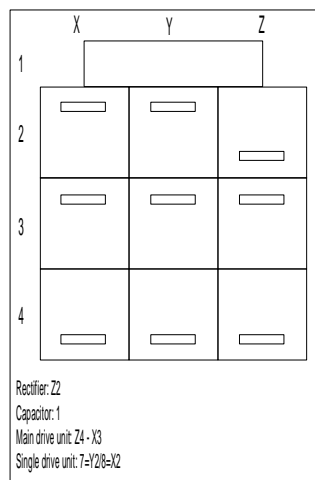

xx0300000184

Pos.	Identification	Description	Art. no.	Note
1	DSQC 620_C3	Capacitor unit	3HAC14551-2	
Z2	DSQC 618_R3	Rectifier	3HAC14549-3	
Y2, X2	DSQC 619	Optional drive units for external axes	3HAC14550-4	Size: 1W
Z4, Y4, X4, Z3, Y3, X3	DSQC 617_3V3W	Main Drive unit	3HAC025338-006	Z4 - X3 is ONE unit!

2 Installation and Commissioning, IRC5

2.6.4. Configuration of Drive System 09, IRC5

2.6.4. Configuration of Drive System 09, IRC5

General

The IRC5 Controller contains one Main Drive Unit and up to three Additional Drive Units, and in some cases an Additional Rectifier Unit. The allowed combinations of these, depending on the robot type, is specified below.

The robot system may also be equipped with up to three additional drive modules, which are described in section *Installation of additional Drive Module on page 106*.

Location

The drive system is located in the Single Cabinet Controller as shown below.

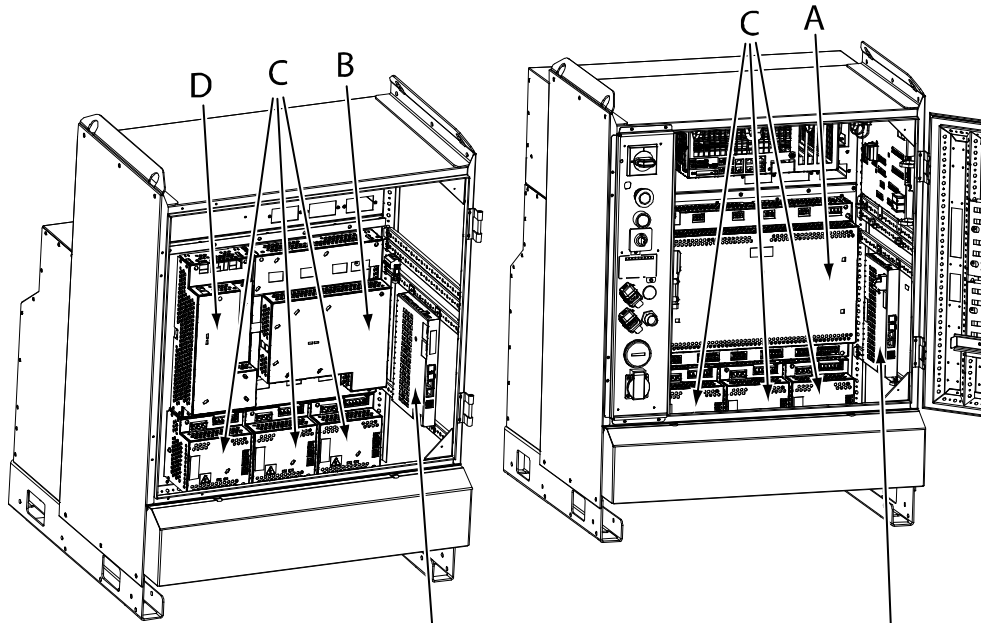

xx100000001

A	Main Drive Unit MDU-790A (for large robots)
B	Main Drive Unit MDU-430A (for small robots)
C	Additional Drive Units (for additional axes)
D	Additional Rectifier Unit (only used for additional axes in combination with small robots)

DC bus cables

Between the units are fitted DC bus cables, which are specified below:

Description	Art. no.	Note
DC bus cable	3HAC032612-001	Between Main Drive Unit MDU-790A and Additional Drive Units.
DC bus cable	3HAC036612-001	Between Additional Rectifier Unit and first Additional Drive Unit.
DC bus cable	3HAC036612-002	Between Additional Rectifier Unit and second Additional Drive Unit.
DC bus cable	3HAC036612-003	Between Additional Rectifier Unit and third Additional Drive Unit.

Continues on next page

Continued

IRB 120, 140, 1410, 260, 340, 360, 1600

The following illustration shows the drive units. The table specifies which units may be fitted in which positions.

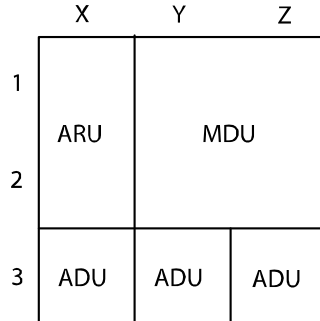

en0800000293

Pos.	Identification	Description	Art. no.	Note
Y1, Y2, Z1, Z2	DSQC 406	Main Drive Unit MDU-430A	3HAC035301-001	
X1, X2	DSQC 417	Additional Rectifier Unit ARU-430A	3HAC035381-001	Required if any Additional Drive Unit is used.
X3	DSQC 664	Additional Drive Unit ADU-790A	3HAC030923-001	For first additional axis
Y3	DSQC 664	Additional Drive Unit ADU-790A	3HAC030923-001	For second additional axis
Z3	DSQC 664	Additional Drive Unit ADU-790A	3HAC030923-001	For third additional axis

IRB 2400, 2600, 4400, 4600, 6400R, 6600, 6620, 6640, 6650, 6660, 660, 7600

The following illustration shows the drive units. The table specifies which units may be fitted in which positions.

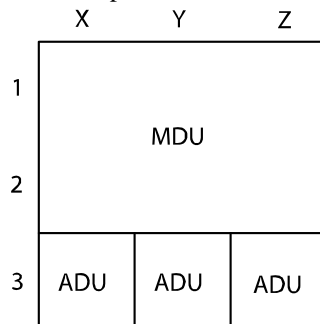

en0800000292

Pos.	Identification	Description	Art. no.	Note
X1, X2, Y1, Y2, Z1, Z2	DSQC 663	Main Drive Unit MDU-790A	3HAC029818-001	

2 Installation and Commissioning, IRC5

2.6.4. Configuration of Drive System 09, IRC5

Continued

Pos.	Identification	Description	Art. no.	Note
X3	DSQC 664	Additional drive unit ADU-790A	3HAC030923-001	For first additional axis
Y3	DSQC 664	Additional drive unit ADU-790A	3HAC030923-001	For second additional axis
Z3	DSQC 664	Additional drive unit ADU-790A	3HAC030923-001	For third additional axis

2.7 Memory functions

2.7.1. Memory functions

General

The controller may be fitted with memory functions found inside the Computer Module.

The memory functions are divided into two main categories:

- Mass memory (hard disk drive, solid state disk drive, etc.)
- RAM memory (memory modules fitted on the main computer motherboard)

Computer units

Computer unit DSQC639:

- Compact flash memory 1 GB containing ABB boot image software.
- 256 MB DDR SDRAM memory (Synchronous Dynamic Random Access Memory).



Note

NOTE!

Only use Compact flash memory and DDR SDRAM memory supplied by ABB.

Further information

The table gives references to additional information.

Information:	Found in:
How to replace malfunctioning memory units and restore the drive system to full operation:	Section Replacement of Compact Flash memory in computer unit DSQC639 on page 223 Section Replacement of motherboard in computer unit DSQC639 on page 204 . Section Replacement of DDR SDRAM memory on motherboard in computer unit DSQC639 on page 207

2 Installation and Commissioning, IRC5

2.7.2. Connecting a USB memory to the computer unit

2.7.2. Connecting a USB memory to the computer unit

Location DSQC639

A USB memory may be connected to either one of the USB ports on the computer unit. The location of the USB ports is shown by the following illustration:

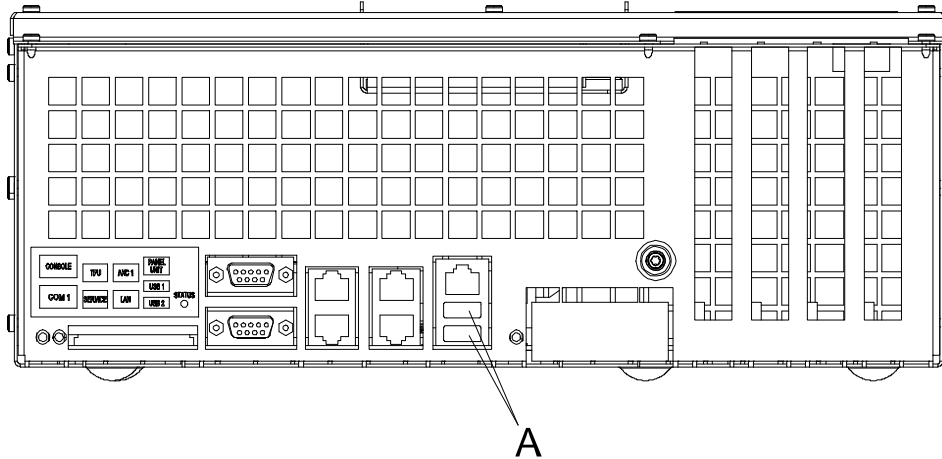

xx0600002895

A	USB 1, 2 The USB connectors provide two legacy USB 2.0 ports supporting High Speed/Full Speed/Low Speed (HS/FS/LS)
---	--

Connection

Action	Info/illustration
<p>1. Open the connector cover on the controller or open the door, (Control Module on the Dual Cabinet).</p>	<p style="text-align: center;">xx0600002894</p> <ul style="list-style-type: none"> • A: USB port
<p>2. Remove the end cover on the USB memory and connect it to the connector. Do not disconnect the USB memory within approx. 10 seconds after connecting it.</p>	<p>The USB memory and its contents may now be accessed from the computer unit just as any other hard drive unit.</p>

© Copyright 2004-2010 ABB. All rights reserved.

Continues on next page

Continued

	Action	Info/illustration
3.	 <p>CAUTION!</p> <p>CAUTION! Handling of USB memory is described in Operating manual - IRC5 with Flex-Pendant, section File Managing.</p>	

2 Installation and Commissioning, IRC5

2.8.1. Definition of I/O units, IRC5

2.8 I/O system

2.8.1. Definition of I/O units, IRC5

General

The IRC5 controller may be fitted with I/O, Gateway or Encoder units. These are configured in an identical way.

The IRC5 Single Cabinet Controller is prepared for up to two I/O units, Gateways or Encoder interfaces units, and the Dual Cabinet Controller (Control Module) is prepared for up to four I/O units, Gateways or Encoder interface units. This means that the harness inside the IRC5 controller is equipped with necessary connectors.

For the Single Cabinet Controller the I/O, Gateway or Encoder units are placed on the inside of the door as shown in the illustration below. For the Dual Cabinet Controller the units are mounted in the Control Module.

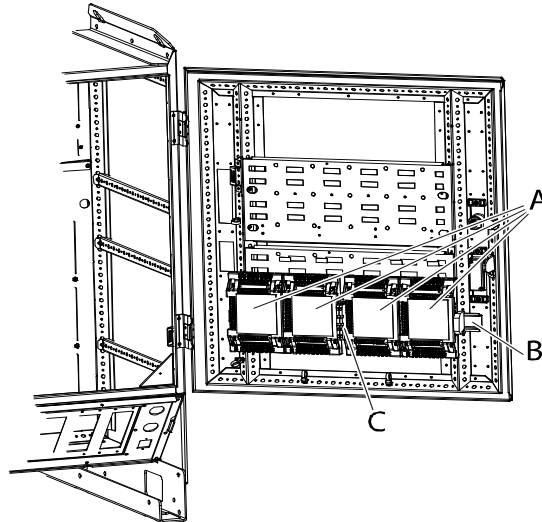

xx0500001859

A	I/O, Gateway or Encoder units
B	Mounting rail

Standard configuration

In the standard form, no fieldbus is mounted to the controller. However, the digital inputs and outputs are available on the customer plate in the control module.

It is possible to connect any type of DeviceNet compliant I/O unit on the DeviceNet - master bus. All I/O units should comply with the DeviceNet standard and be conformance tested by ODVA.

I/O units

The table below specifies the I/O units:

Description	Note
AD Combi I/O	DSQC 651 See <i>I/O System parts on page 304</i> for the spare part number
Digital I/O	DSQC 652 See <i>I/O System parts on page 304</i> for the spare part number
Digital I/O with relay outputs	DSQC 653 See <i>I/O System parts on page 304</i> for the spare part number

Gateways

The table below specifies the Gateways:

Description	Art. no.	Note
DeviceNet/Allen Bradely Remote I/O Gateway	3HNE00025-1	DSQC 350A
DeviceNet/Interbus Gateway	3HNE00006-1	DSQC 351A

Encoder interface units

The table below specifies the encoder interface units:

Description	Art. no.	Note
Encoder interface unit for conveyor tracking	3HNE01586-1	DSQC 377A.

Further information

The table below gives references to additional information:

Information:	Found in:
How to install the I/O units and Gateways mechanically and electrically.	Section <i>Installation of I/O, Gateways and encoder interface units, IRC5 on page 118</i> .
Allowed configurations of I/O units and how to setup the configurations.	Technical reference manual - System parameters
How to install the I/O unit and Gateways software related in a new system.	The Application manual for the different I/O buses respectively.
Detailed descriptions of all available I/O units and Gateways.	The Application manual for the different I/O buses respectively.

2 Installation and Commissioning, IRC5

2.9.1. Installation of additional Drive Module

2.9 Installation of add-ons

2.9.1. Installation of additional Drive Module

General

To be able to use a Multi Move system or to control more than 3 additional axes, an additional Drive Module is needed. The IRC5 controller is prepared for up to three additional Drive Modules.

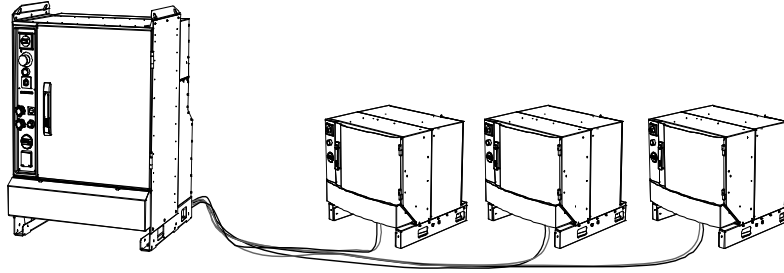

xx0400001042

Prerequisites

Equipment	Note
Additional Drive Module (Includes all cabling and required mounting hardware)	Specified in Specification Form
Ethernet board	DSQC 612 See Computer unit DSQC 639 parts on page 305 for the spare part number
Standard toolkit	The contents are defined in section Standard toolkit!
Other tools and procedures may be required. See references to these procedures in the step-by-step instructions below.	These procedures include references to the tools required.
Circuit Diagram	See Circuit Diagram on page 319

Procedure

The procedure below details how to install the additional drive module.

	Action	Info/Illustration
1.	 DANGER! Before commencing any work inside the cabinet, please observe the safety information in section DANGER - Make sure that the main power has been switched off! on page 30 .	

© Copyright 2004-2010 ABB. All rights reserved.

Continues on next page

Continued

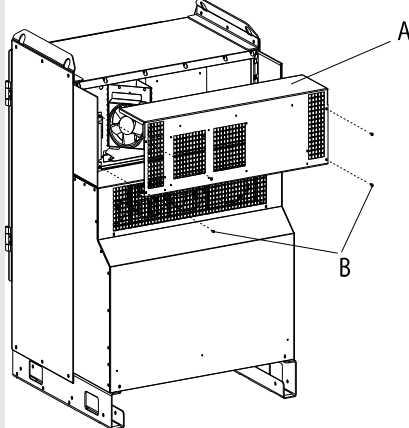
	Action	Info/Illustration
2.	 <p>esd</p> <p>WARNING! The unit is sensitive to ESD. Before handling the unit please read the safety information in the section WARNING - The unit is sensitive to ESD! on page 31</p>	
3.	Fit the DSQC 612 Ethernet board into the computer unit.	How to fit the Ethernet board is detailed in section Replacement of PCI boards in the computer unit DSQC639 on page 211 .
4.	Place the additional drive module in position and secure it with the included screws and washers.	
5.	Remove the top cover.	 <p>xx0500001887</p> <p>Parts:</p> <ul style="list-style-type: none"> • A: top cover • B: attachment screw (4pcs)

2 Installation and Commissioning, IRC5

2.9.1. Installation of additional Drive Module

Continued

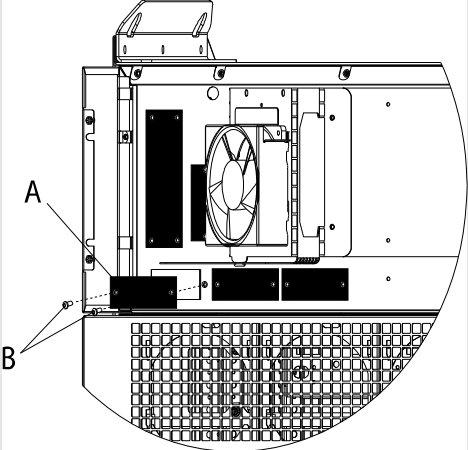
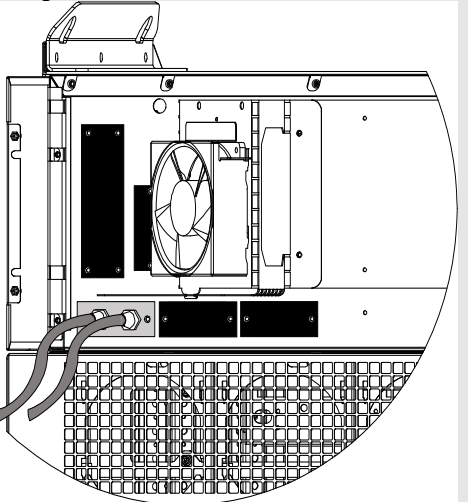
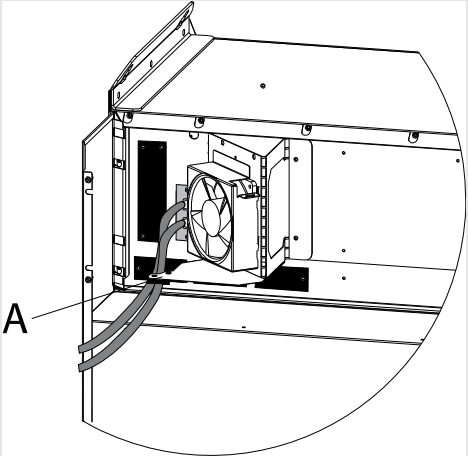
	Action	Info/Illustration
	<p>6. Loosen the attachment screws, and remove the cover to a empty slot in the back of the controller.</p>	 <p>xx0500001888</p> <ul style="list-style-type: none"> • A: cover • B: attachment screw (2pcs)
	<p>7. Fit the communication cabling with cover with two attachment screws.</p> <p>When connecting the 4:th Drive Module (MultiMove system) to a Dual Cabinet, strap the cables according to the image.</p>	<p>Single Cabinet:</p>  <p>xx0500001889</p> <p>Dual Cabinet:</p>  <p>xx0700000415</p> <ul style="list-style-type: none"> • A: cable strap

© Copyright 2004-2010 ABB. All rights reserved.

Continues on next page

Continued

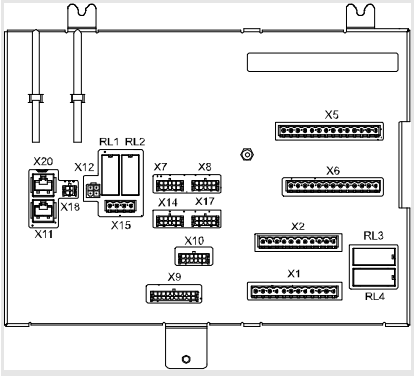
	Action	Info/Illustration
8.	<p>Connect the ethernet cable (A32.X9) to the DSQC 612 Ethernet board.</p> <p>Connector:</p> <ul style="list-style-type: none"> A32.X9 to Ethernet board connector, AXC1 	
9.	<p>Connect the safety signal cable (A21.X7) to the Panel board.</p> <p>Connector:</p> <ul style="list-style-type: none"> A21.X8 - 1 additional drive A21.X14 - 2 additional drives A21.X17 - 3 additional drives 	 <p>xx0400001890</p>
10.	<p>Strap the cabling to existing straps inside the module.</p>	

2 Installation and Commissioning, IRC5

2.9.2. Installation of external operator's panel, IRC5

2.9.2. Installation of external operator's panel, IRC5

Location

An external operator's panel may be fitted in a separate wall cabinet as shown in the illustration below.

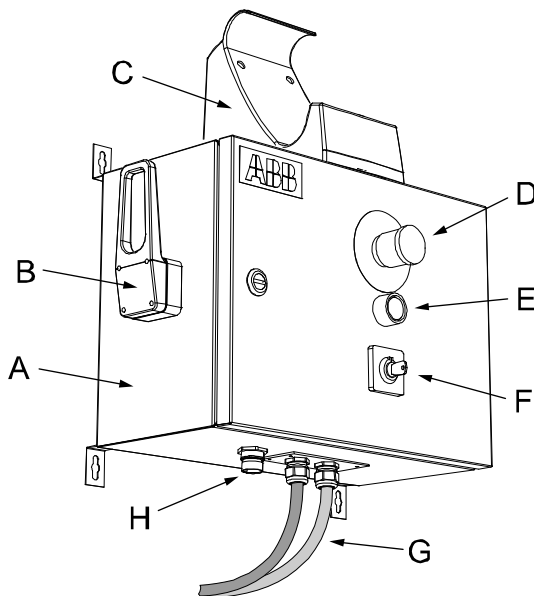

xx0400000956

A	Wall cabinet IRC5
B	Bracket
C	FlexPendant holder
D	Emergency stop button
E	Motor ON button
F	Position mode switch
G	External Operator's panel harness
H	FlexPendant connector

Required equipment

Equipment	Art. no.	Note
Wall cabinet IRC5	3HAC022035-001	
External Operator's panel cable	3HAC021273-005	30 m
	3HAC021273-001	22 m
	3HAC021273-006	15 m
Standard toolkit		The contents are defined in section, <i>Standard Toolkit</i> .
Other tools and procedures may be required. See references to these procedures in the step-by-step instructions below.		These procedures include references to the tools required.
Circuit Diagram		See <i>Circuit Diagram on page 319</i>

Continues on next page

Procedure

The procedure below details how to install the external control panel.

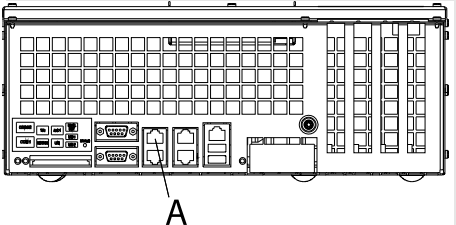
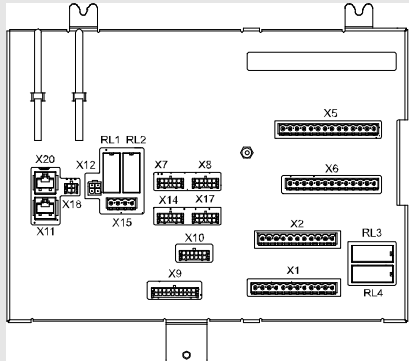
	Action	Info/Illustration
1.	 <p>DANGER! Before commencing any work inside the cabinet, please observe the safety information in section <i>DANGER - Make sure that the main power has been switched off!</i> on page 30.</p>	
2.	<p>Disconnect the cable from the ethernet connector for FlexPendant on the computer unit.</p>	<p>DSQC639:</p>  <p>xx0600002897</p> <ul style="list-style-type: none"> A: FlexPendant port
3.	<p>Disconnect signal cabling from the panel board unit.</p> <p>Connectors:</p> <ul style="list-style-type: none"> A21.X9 A21.X10 	 <p>xx0500001890</p>

2 Installation and Commissioning, IRC5

2.9.2. Installation of external operator's panel, IRC5

Continued

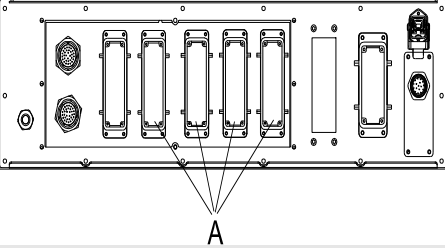
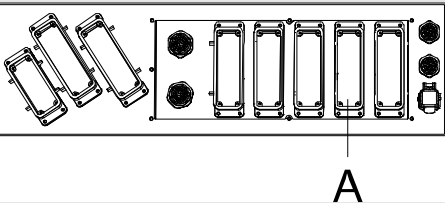
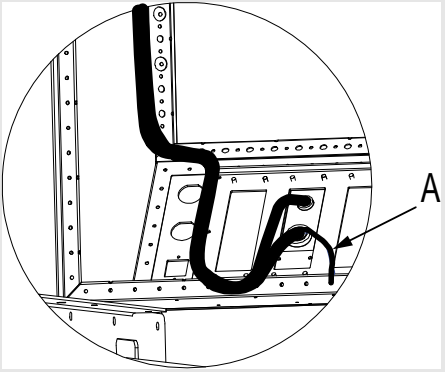
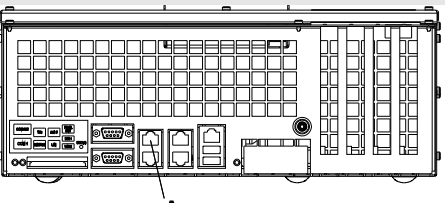
	Action	Info/Illustration
	<p>4. Remove the cover to a free customer connector slot on the connection panel.</p>	<p>The illustration below shows the connection panel for the Dual Cabinet Controller.</p>  <p>xx0400000966</p> <ul style="list-style-type: none"> A: Customer connection slot <p>The illustration below shows the connection panel for the Single Cabinet Controller.</p>  <p>xx0500001960</p> <ul style="list-style-type: none"> A: Customer connection slot
	<p>5. Fit the Harness from the external control panel to the empty slot with the four attachment screws.</p>	
	<p>6. Connect the earth cable to the chassi.</p>	 <p>xx0700000619</p> <ul style="list-style-type: none"> A: earth cable
	<p>7. Connect the ethernet connector A32.A8 to the computer unit.</p>	<p>DSQC639:</p>  <p>xx0600002897</p> <ul style="list-style-type: none"> A: FlexPendant port

© Copyright 2004-2010 ABB. All rights reserved.

Continues on next page

Continued

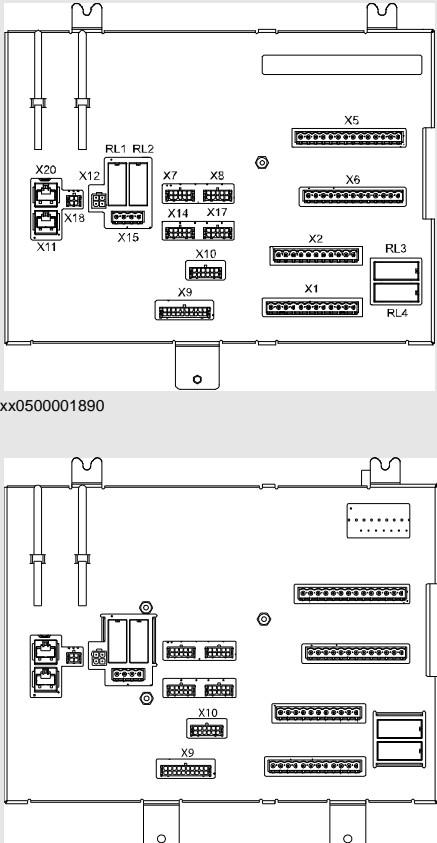
Action	Info/Illustration
<p>8. Connect the signal connectors A21.X9 and A21.X10 to the <i>connector X9 and X10</i> on the panel board unit.</p>	 <p>xx0500001890</p> <p>xx0600003257</p>
<p>9. Strap the cabling to the existing cable strapping inside the module.</p>	
<p>10. Fit the cabling to the wall cabinet with the two attachment screws.</p>	
<p>11. Connect the connectors inside the wall cabinet.</p>	<p>Connectors inside wall cubicle.</p> <ul style="list-style-type: none"> • A21.X9 to X9 • A22.X2 to X2 • A22.X3 to X3

2 Installation and Commissioning, IRC5

2.9.3. Installation of Drive system parts (Drive System 04)

2.9.3. Installation of Drive system parts (Drive System 04)

Location

The illustration below shows the location of the drive system in a Single Cabinet Controller, in a Dual Cabinet Controller the drive system components are located in the Drive Module.

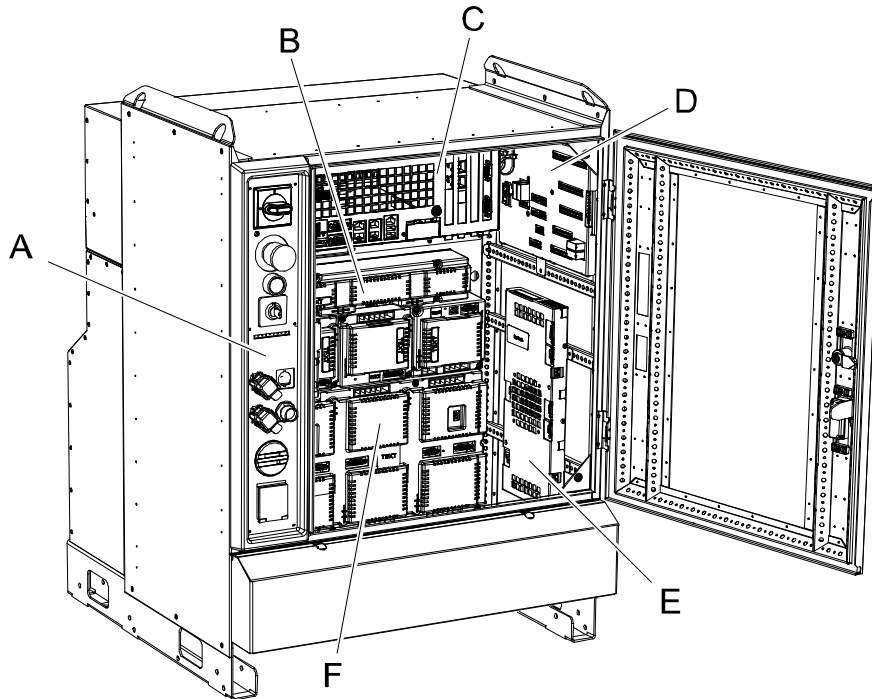

xx0500001858

A	Operator's panel
B	Capacitor
C	Computer unit
D	Panel unit
E	Axis computer
F	Drive units/Rectifier

Required equipment

Equipment	Art. no.	Note
A number of choices are available		Specified in section Configuration of Drive System 04, IRC5 on page 91 .
Standard toolkit		The contents are defined in section Standard toolkit.
Other tools and procedures may be required. See references to these procedures in the step-by-step instructions below.		These procedures include references to the tools required.
Application manual - Additional axes and stand alone controller	3HAC021395-001	Contains information on how to configure the system for additional axes.
Circuit Diagram		See Circuit Diagram on page 319

Continues on next page

Procedure

The procedure below details how to install a drive unit.

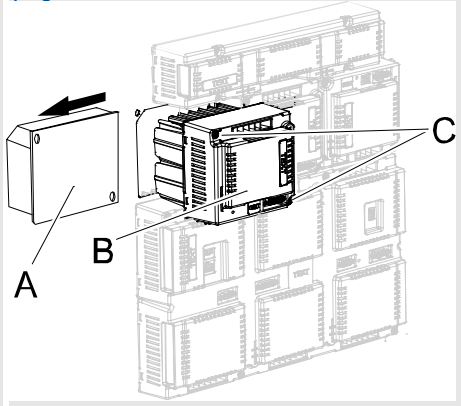
	Action	Note/Illustration
1.	 <p>DANGER! Before commencing any work inside the cabinet, please observe the safety information in section <i>DANGER - Make sure that the main power has been switched off!</i> on page 30.</p>	
2.	Remove the dummy by unscrewing its attachment screws.	<p>Location is detailed in section <i>Location on page 114.</i></p>  <p>xx0500001843</p> <p>Parts:</p> <ul style="list-style-type: none"> • A: dummy • B: drive unit • C: attachment screw
3.	Fit the drive unit in position. Secure it with its attachment screws.	Allowed positions are specified in section <i>Configuration of Drive System 04, IRC5 on page 91</i>
4.	Connect any additional connectors to the unit.	
5.	Make sure the robot system is configured to reflect the drive functions installed.	<p>Basic robot drive functionality is configured in System Builder in RobotStudio.</p> <p>Additional axes detailed in documents specified above!</p>

2 Installation and Commissioning, IRC5

2.9.4. Installation of Drive system parts (Drive System 09)

2.9.4. Installation of Drive system parts (Drive System 09)

Location

The illustration shows the location of drive units in a Single Cabinet Controller.

In the Dual Cabinet Controller the servo drive components are located in the Drive Module.

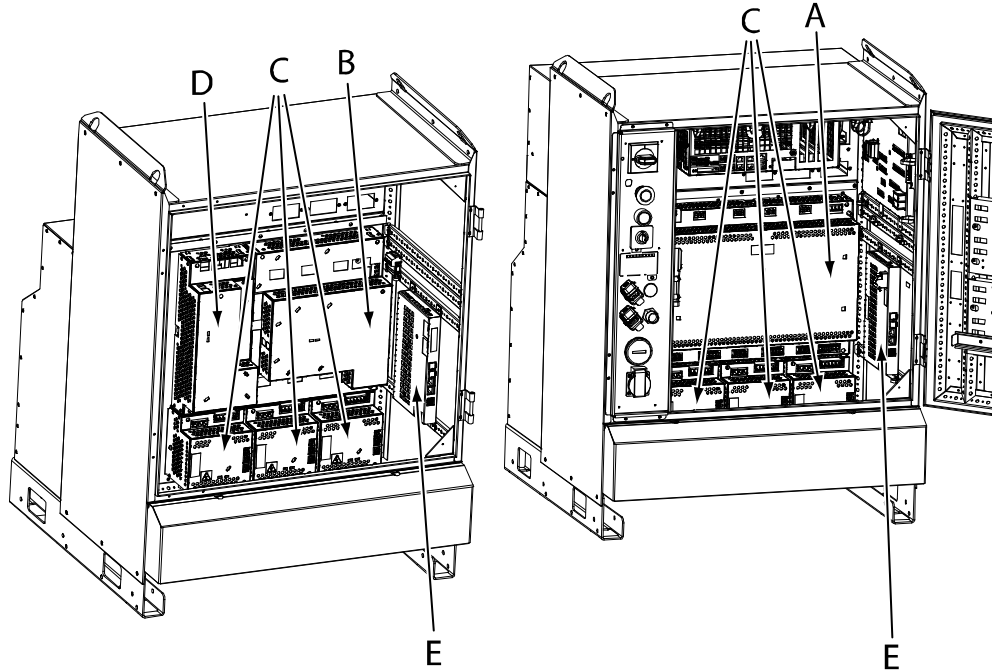

xx100000001

A	Main Drive Unit for large robots
B	Main Drive Unit for small robots
C	Additional Drive Units (for additional axes)
D	Additional Rectifier Unit (only used for additional axes in combination with small robots)

Configuration

The drive module exists in a number of versions, these are described in section [Configuration of Drive System 09, IRC5 on page 98](#).

Required equipment

Equipment	Note
Drive units	Specified in section Configuration of Drive System 09, IRC5 on page 98 .
Standard toolkit	The contents are defined in section Standard toolkit, IRC5 on page 299 .
Other tools and procedures may be required. See references to these procedures in the step-by-step instructions below.	These procedures include references to the tools required.
Circuit Diagram	See Circuit Diagram on page 319 .

© Copyright 2004-2010 ABB. All rights reserved.

Continues on next page

Installing an Additional Drive Unit

The procedure below details how to install an Additional Drive Unit.



NOTE!

When using Main Drive Unit MDU-430A an Additional Rectifier Unit, ARU-430A, is required to use an Additional Drive Unit. The Additional Rectifier Unit is installed to the left of the Main Drive Unit. The installation is similar to that of the Additional Drive Unit.

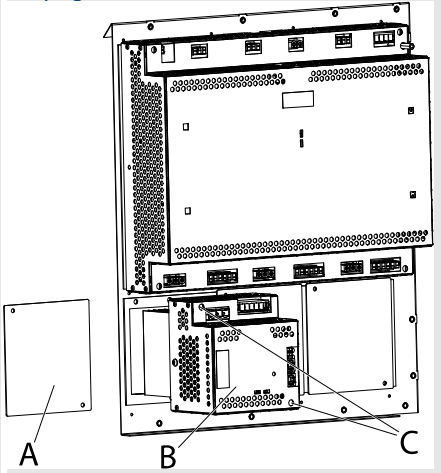
	Action	Note/Illustration
1.	 <p>DANGER! Before any work inside the cabinet, please observe the safety information in section <i>DANGER - Make sure that the main power has been switched off!</i> on page 30.</p>	
2.	Remove the cover plate by unscrewing its attachment screws.	<p>Location is detailed in section <i>Location</i> on page 116.</p>  <p>xx0900000127</p> <p>Parts:</p> <ul style="list-style-type: none"> • A: cover plate • B: Additional Drive Unit • C: attachment screws
3.	Fit the drive unit in its intended position and orientation. Secure it with its <i>attachment screws</i> .	
4.	Connect any additional connectors to the drive unit.	
5.	Make sure the robot system is configured to reflect the drive functions installed.	<p>Basic robot drive functionality is configured in System Builder in RobotStudio.</p> <p>For information about additional axes, see <i>Application manual - Additional axes and stand alone controller</i>.</p>

2 Installation and Commissioning, IRC5

2.9.5. Installation of I/O, Gateways and encoder interface units, IRC5

2.9.5. Installation of I/O, Gateways and encoder interface units, IRC5

Location in Single Cabinet Controller

The location for the I/O units, Gateway or encoder interface units to be installed are shown in the illustration below.

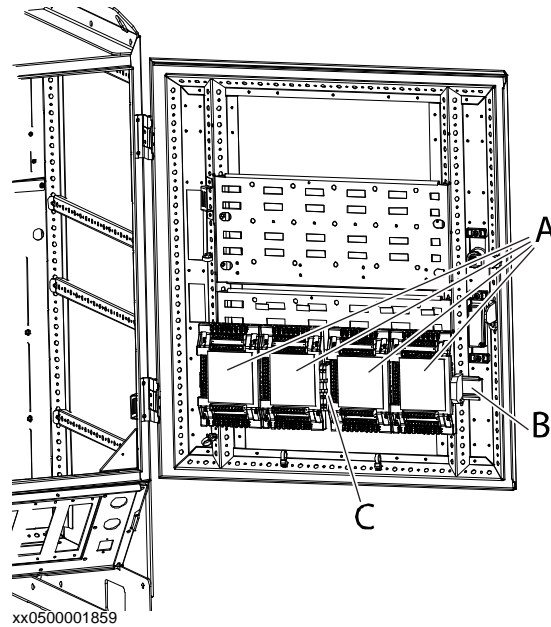

A	I/O units, Gateways or encoder interface units
B	Mounting rail
C	Connection terminal XT31

Location in Dual Cabinet Controller

The location of I/O units, Gateways or encoder interface units in the Dual Cabinet Controller is shown in the illustration below.

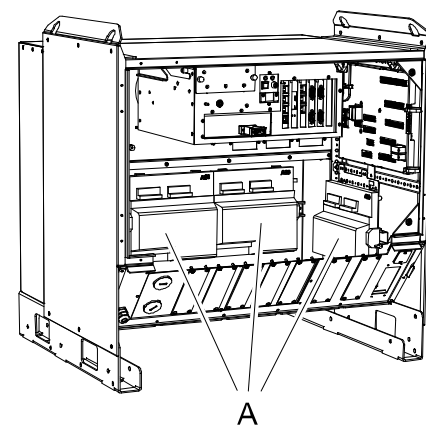

A	I/O units, Gateways or encoder interface units
---	--

Required equipment

Equipment	Art. no.	Note
I/O units, Gateways or encoder interface units		Specified in <i>Definition of I/O units, IRC5 on page 104.</i>
Application manual - DeviceNet	3HAC020676-001	
Circuit Diagram		See <i>Circuit Diagram on page 319</i>

Fitting

The procedure below details how to fit the units.

	Action	Note/Illustration
1.	 <p>DANGER! Before commencing any work inside the cabinet, please observe the safety information in section <i>DANGER - Make sure that the main power has been switched off! on page 30.</i></p>	
2.	Fit the I/O unit by snapping it onto the mounting rail.	
3.	Connect the DC supply to the board.	
4.	Connect wires to the inputs and output connectors as required.	Described in the Application manual for the respective busses.

24 V power supply

I/O units are supplied with 24 V power from the connector XT31 (see previous illustration).

Parallel connection

The 24V coming from DSQC 662, terminal XT31.1, can not be increased by adding power from any other 24 V power supply (not even DSQC 609). There is no load levelling function that ensures current distribution. The unit will not be destroyed but the lifetime may be affected.

The parallel connection of two DSQC 609 is permitted (factory setting) but not more than two.

2 Installation and Commissioning, IRC5

2.9.6. Installation of PMC-card for Force Control Function (Drive System 04)

2.9.6. Installation of PMC-card for Force Control Function (Drive System 04)

Limitations

This section describes how to install a PCM-card on a Controller with Drive System 04. This solution is not possible for Drive System 09.

Location

The PMC-card shall be mounted on the axis computer card. The axis computer is located as shown in the illustration below.

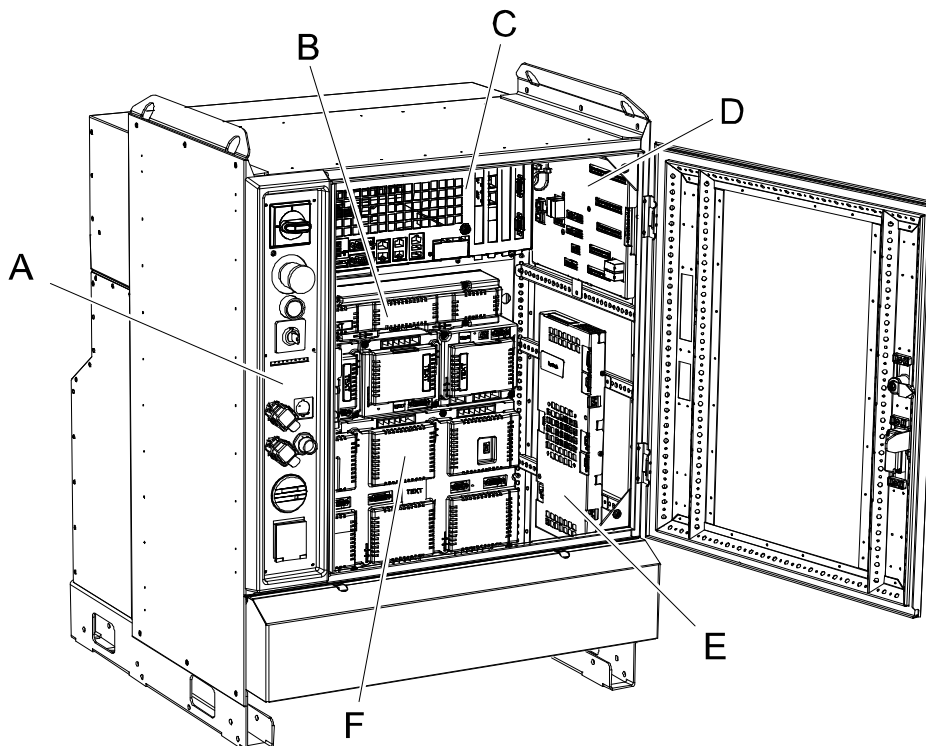

xx0500001858

A	Operator's panel
B	Capacitor
C	Computer unit
D	Panel unit
E	Axis computer
F	Drive system (drive units and rectifier)

Required equipment

Equipment	Art. no.	Note
6-DOF sensor		ATI
PMC-card		Supplied with the sensor
Cable between the sensor and PMC-card		Supplied with the sensor
RW Force Control Software		Option no: Assembly: 661-2

© Copyright 2004-2010 ABB. All rights reserved.



Continues on next page

Continued

Equipment	Art. no.	Note
Application manual - Force Control Assembly	3HAC025057-001	
Operating manual - RobotStudio	3HAC032104-001	
Standard tool kit.		
Circuit diagram		See <i>Circuit Diagram on page 319</i>

Procedures

The following procedures details how to install the PMC-card on the axis computer card.

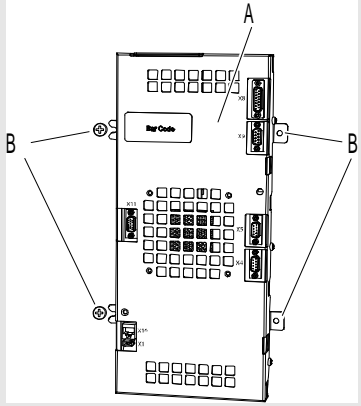
	Action	Note/illustration
1.	 <p>DANGER! Before commencing any work inside the cabinet, please observe the safety information in section <i>DANGER - Make sure that the main power has been switched off!</i> on page 30.</p>	
2.	 <p>esd WARNING! The unit is sensitive to ESD. Before handling the unit please read the safety information in the section <i>WARNING - The unit is sensitive to ESD!</i> on page 31</p>	
3.	Remove the attachment screws and pull out the axis computer.	 <p>xx0500002002</p> <ul style="list-style-type: none"> • A: axis computer • B: attachment screws

2 Installation and Commissioning, IRC5

2.9.6. Installation of PMC-card for Force Control Function (Drive System 04)

Continued

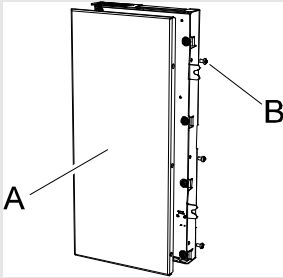
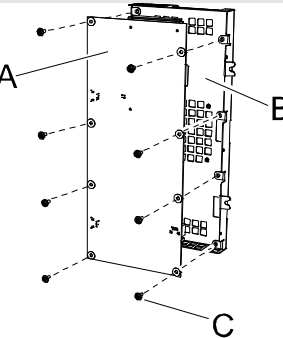
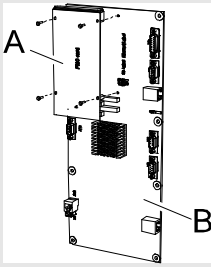
	Action	Note/illustration
	<p>4. Remove the six attachments screws on the sides of the axis computer, and remove the back cover.</p>	 <p>xx0500002134</p> <ul style="list-style-type: none"> • A: back cover • B: attachment screw (6pcs)
	<p>5. Remove the eight attachment screws holding the board to the front cover, and lift out the board.</p>	 <p>xx0500002137</p> <ul style="list-style-type: none"> • A: axis computer board • B: front cover • C: attachment screw (8pcs)
	<p>6. Mount the PMC-card according to the picture, and secure it with the four attachment screws.</p>	 <p>xx0500002138</p> <ul style="list-style-type: none"> • A: PMC-card with attachment screws • B: axis computer board

© Copyright 2004-2010 ABB. All rights reserved.

Continues on next page

Continued

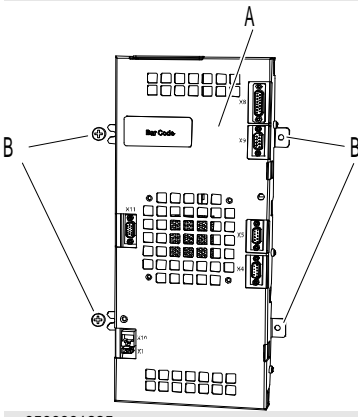
	Action	Note/illustration
7.	Refit the axis computer in controller.	 <p style="font-size: small;">xx0500001885</p> <ul style="list-style-type: none"> • A: axis computer • B: attachment screws
8.	Install the Force Control software.	Installation of the software is described in <i>Operating manual - RobotStudio</i>

2 Installation and Commissioning, IRC5

2.9.7. Installation of Force Control for Drive System 09

2.9.7. Installation of Force Control for Drive System 09

About Force Control hardware

An IRC5 controller with Drive System 09 does not require any specific hardware inside the cabinet for Force Control. Instead an external voltage measurement box is connected to Serial Measurement Link 2. For more information on how to connect this, see *Application manual - Force Control for Assembly* or *Application manual - Force Control for Machining*.

2.9.8. Upgrading and installation of 2X Euromap interface (Option 671-4)

General

This section describes installation of 2X Euromap interface (Option 671-4) in an IRC5 Single Cabinet Controller and in an IRC5 Dual Cabinet Controller. The customer option 2X Euromap interface is not a pre mounted delivery option, it must be complimented with a safety relay, not included in the option kit from ABB.



NOTE!

The 2X Euromap interface (Option 671-4) is an upgrade option and demands a pre installed Euromap installation.



NOTE!

The harness used when installing 2X Euromap is identical with the pre mounted Euromap 1 harness. Beware of the identical connection markings.

Location of Euromap 2X interfaces in the Single Cabinet Controller

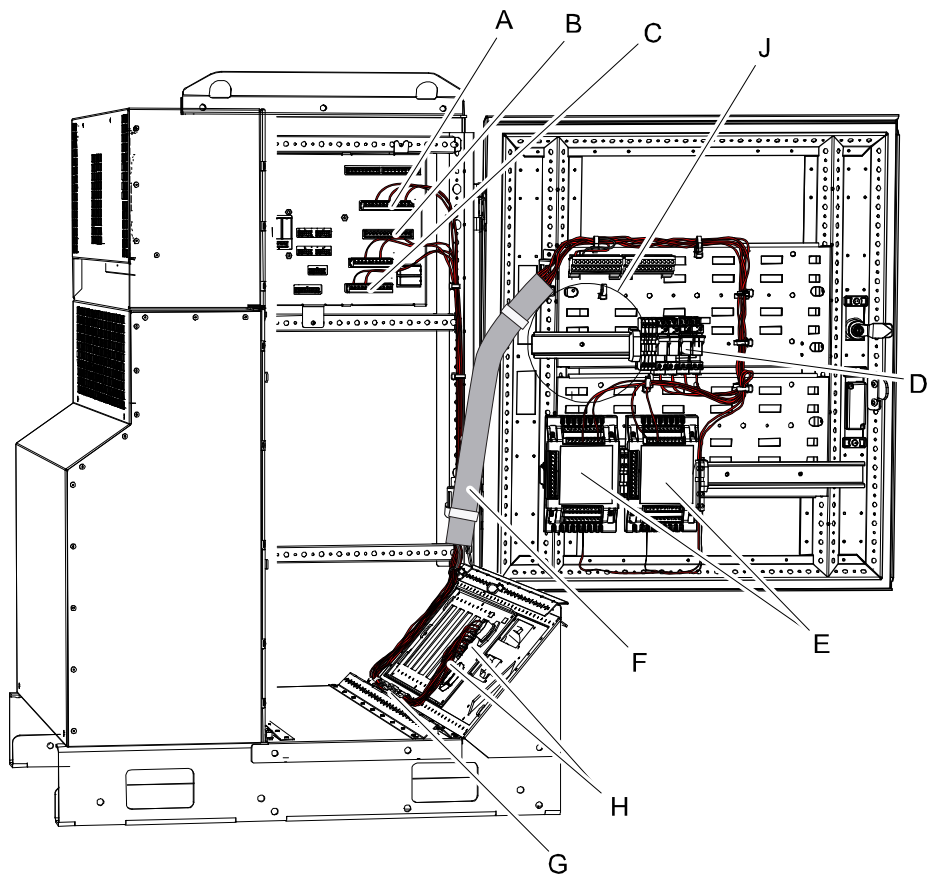

xx0800000214

A	Connector A21.X5, on panel board
B	Connector A21.X1, on panel board
C	Connector A21.X2, on panel board
D	Relay 24K1 and relay 24K2
E	2X Euromap 67: Digital 24 VDC I/O

Continues on next page

2 Installation and Commissioning, IRC5

2.9.8. Upgrading and installation of 2X Euromap interface (Option 671-4)

Continued

F	Cable protection
G	Euromap adapter
H	X13x and X14z connector
J	Placement of customer safety relay

Location of Euromap 2X interfaces in the Dual Cabinet

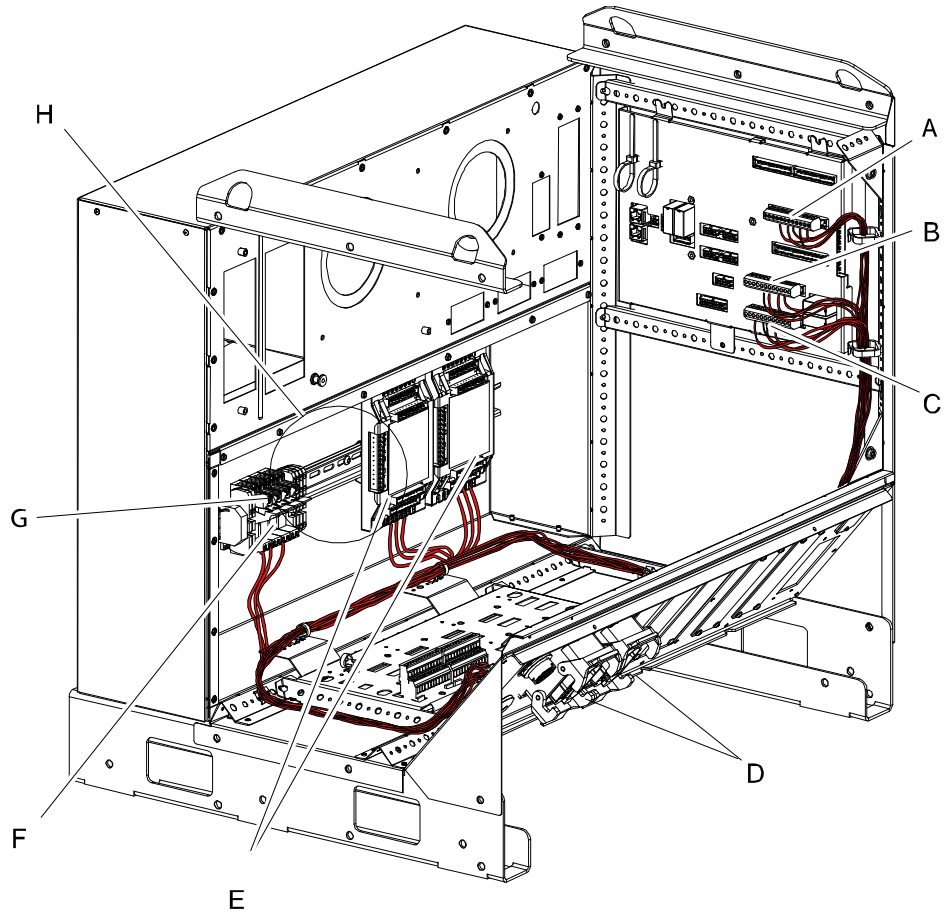

xx0800000215

A	Connector A21.X5, on panel board
B	Connector A21.X1, on panel board
C	Connector A21.X2, on panel board
D	X13x and X14z connector
E	2X Euromap 67: Digital 24 VDC I/O
F	XT31
G	Connector XS13, relay 24K1 and relay 24K2
H	Placement of customer safety relay

© Copyright 2004-2010 ABB. All rights reserved.

Continues on next page

Required equipment for 2X Euromap interfaces in the Single Cabinet Controller

Equipment	Art. number	Description	Note
Cable harness	3HAC026692-001	Harness-Euromap 67 DCC	Single Cab.
Gasket	3HAC024175-001		
Harness-Euromap 67 adapter	3HAC032370-001		
Terminal block	3HAC17833-1		
Marking card	3HAC17833-6		
Standard tools			

Required equipment for 2X Euromap interfaces in the Dual Cabinet

Equipment	Art. number	Description	Note
Cable harness	3HAC026821-001	Harness-Euromap 67 DCC	Dual Cab.
Gasket	3HAC024175-001		
Harness-Euromap 67 adapter	3HAC032370-001		
Terminal block	3HAC17833-1		
Marking card	3HAC17833-6		
Standard tools			

Installation of interfaces in the Single Cabinet Controller

	Action	Note/Illustration
1.	 <p>DANGER! Before commencing any work inside the cabinet, please observe the safety information in section <i>DANGER - Make sure that the main power has been switched off! on page 30.</i></p>	

2 Installation and Commissioning, IRC5

2.9.8. Upgrading and installation of 2X Euromap interface (Option 671-4)

Continued

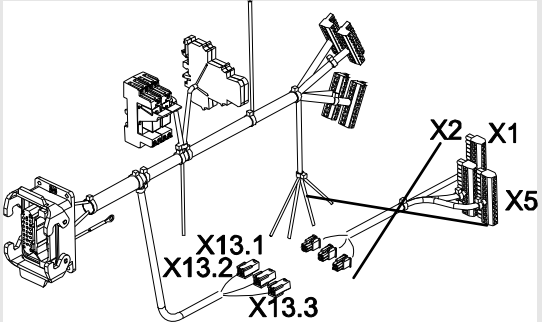
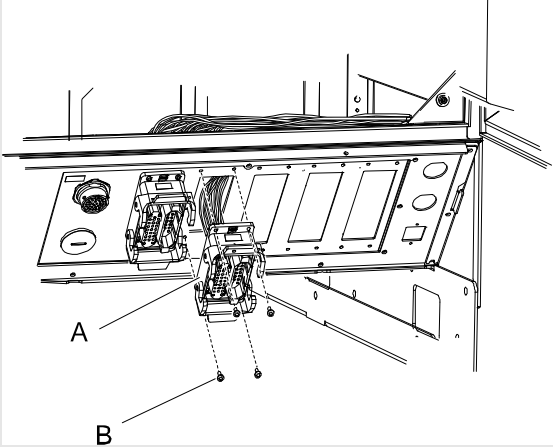
	Action	Note/Illustration
2.	 <p>esd</p> <p>WARNING! The unit is sensitive to ESD. Before handling the unit please read the safety information in the section <i>WARNING - The unit is sensitive to ESD! on page 31</i></p>	
3.	<p>Before assembling the harness 2, disconnect X31.1, X31.2 and X31.3 and discard the harness with the connectors X1, X2 and X5 for the panel board.</p>	 <p>xx0800000218</p>
4.	<p>Fit the harness 2 through the connector hole on the adapter plate, and fit the connector XS14z with the attachment screws.</p>	 <p>xx0800000217</p> <ul style="list-style-type: none"> • A: Connector X14z • B: Attachment screws
5.	<p>Disconnect the connectors X13.1, X13.2 and X13.3 on harness 1.</p>	



© Copyright 2004-2010 ABB. All rights reserved.

Continues on next page

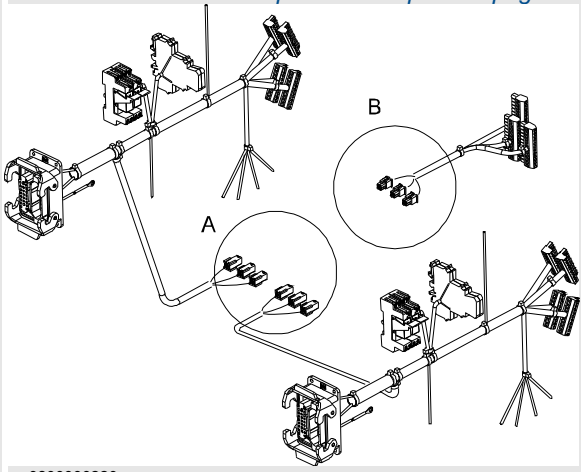
Continued

	Action	Note/Illustration
6.	Use the adapter 3HAC032370-001 to connect (harness 1 with harness 2) ^A and the (panel board harness) ^B , described in section Adapter Euromap 67 on page 132	<p>Described in section Adapter Euromap 67 on page 132.</p>  <p style="text-align: center; font-size: small;">xx0800000220</p>
7.	Connect XP13.3 on harness 1 to XS13.1 on harness 2.	To complete the safety loop, described in section Wiring relay on page 133 .
8.	Connect the harness from the panel board to the adapter.	Connectors X13.1 , X13.2 and X13.3 , described in section Adapter Euromap 67 on page 132 .
9.	Connect the safety relay.	Described in section Installation of safety relay on page 131 .

Installation of interfaces in the Dual Cabinet

	Action	Note/Illustration
1.	 <p>DANGER! Before commencing any work inside the cabinet, please observe the safety information in section DANGER - Make sure that the main power has been switched off! on page 30.</p>	
2.	 <p>esd WARNING! The unit is sensitive to ESD. Before handling the unit please read the safety information in the section WARNING - The unit is sensitive to ESD! on page 31</p>	
3.	Install harness 2 and the adapter 3HAC032370-001.	Described in step 1-8 in section Installation of interfaces in the Single Cabinet Controller on page 127 .
4.	Connect the safety relay.	Described in section Installation of safety relay on page 131 .

Continues on next page

2 Installation and Commissioning, IRC5

2.9.8. Upgrading and installation of 2X Euromap interface (Option 671-4)

Continued

Requirements safety relay

The safety loop demands a safety relay, it is not included in the upgrade kit and has to be supplied by the customer.

Relay specification:

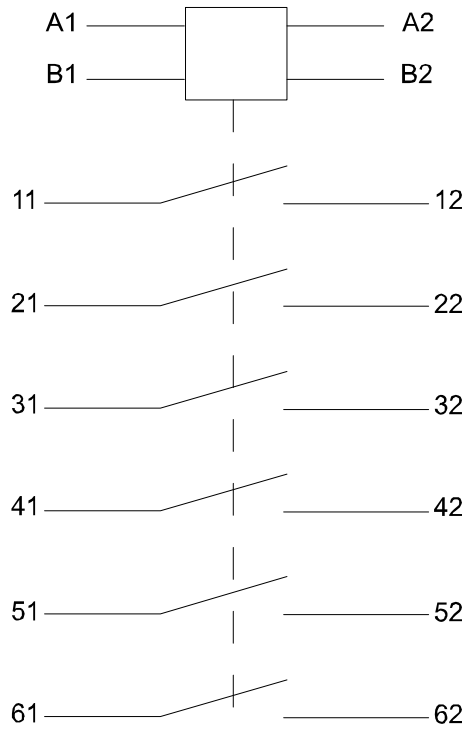

- Two channels
- Six NO contacts



NOTE!

To retain a full functional safety loop during a system power failure, it is important to use an external power source for the customer safety relay.

Installation of safety relay

	Action	Note/Illustration
1.	 <p>DANGER! Before commencing any work inside the cabinet, please observe the safety information in section DANGER - Make sure that the main power has been switched off! on page 30.</p>	
2.	 <p>esd</p> <p>WARNING! The unit is sensitive to ESD. Before handling the unit please read the safety information in the section WARNING - The unit is sensitive to ESD! on page 31</p>	
3.	Assemble the relay (customer supplied) on the recommended location in the IRC5 Controller.	
4.	Connect all wires from the adapter.	Described in Wiring relay on page 133.

2 Installation and Commissioning, IRC5

2.9.8. Upgrading and installation of 2X Euromap interface (Option 671-4)

Continued

Adapter Euromap 67

The figure below shows the connections for the Euromap 67 adapter 3HAC032370-001.

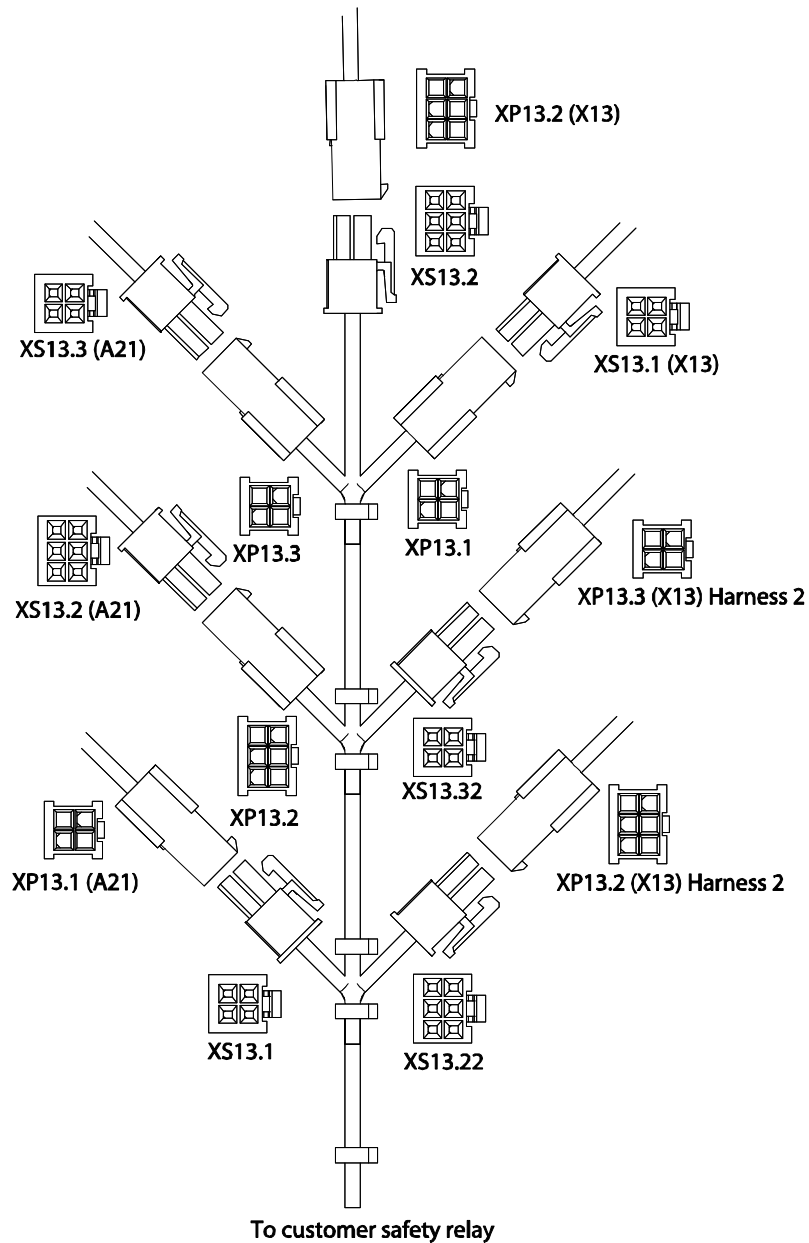

xx0800000216

Wiring adapter

Harness	Connection	From-To	Connection
1	XS13.1	X13-Adapter	XP13.1
	XP13.2	X13-Adapter	XS13.2
	XP13.3	X13-Adapter	XS13.1 (X13 Harness 2)
	XP13.1	A21-Adapter	XS13.1
	XS13.3	A21-Adapter	XP13.3
2	XP13.2	X13-Adapter	XS13.22
	XP13.3	X13-Adapter	XS13.32

© Copyright 2004-2010 ABB. All rights reserved.

Continues on next page

Wiring relay

The figure below shows the connections for the Euromap safety loop.

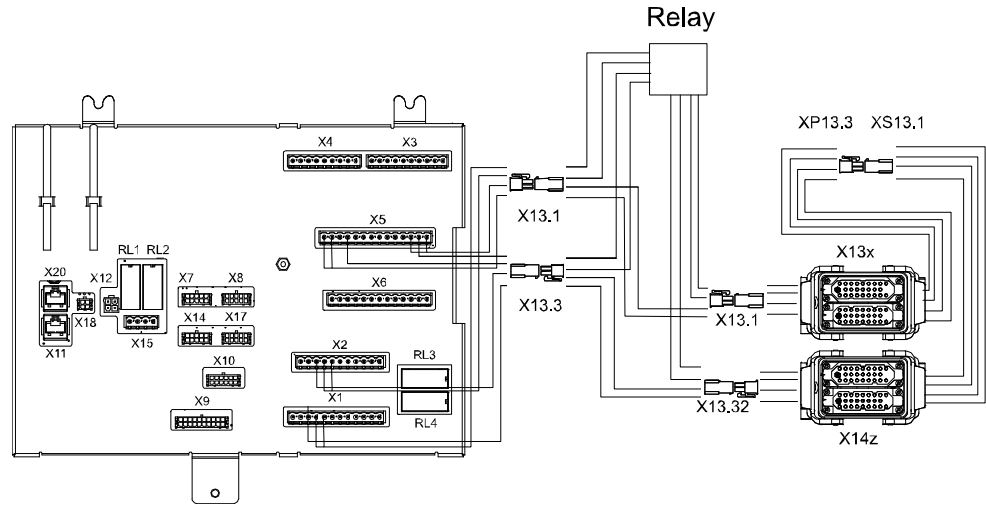

xx0800000219

Wire No.	Connection point A Designation	Term	Connection point B Designation	Term
1200	XS13.1	1	Safety relay	11
1201		2		21
1204	XP13.2	1		B1
1205		2		A1
1208	XS13.2	1	41	
1209		2	31	
1210		3	32	
1211		4	42	
1212	XP13.3	1	12	
1213		2	22	
1216	XS13.22	1	61	
1217		2	51	
1218		3	52	
1219		4	62	
1220	XS13.32	1	A2	
1221		2	B2	
1002	XT8:1	Socket		
1019	XT8:3	Socket		
1032	XT31	1 or 2		
1046	XT31	5 or 6		
1055	XT31	5 or 6		

2 Installation and Commissioning, IRC5

2.9.9. Installation of cooling fan harness axis 1 and 2

2.9.9. Installation of cooling fan harness axis 1 and 2

General

If the robot is going to be supplemented with cooling fans on axis 1 and 2 the controller has to be supplemented with an internal harness.

Locations in Dual Cabinet Controller

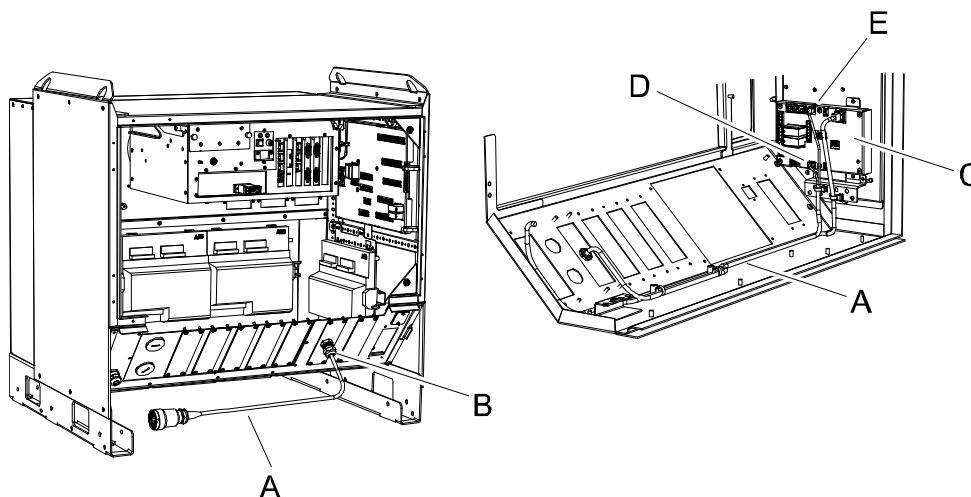

xx0600002685

A	Harness, cooling - Axis 1 and 2
B	Cover with cable gland
C	Contactor interface board
D	Connector A43.X10
E	Connector A43.X11

Locations in Single Cabinet Controller

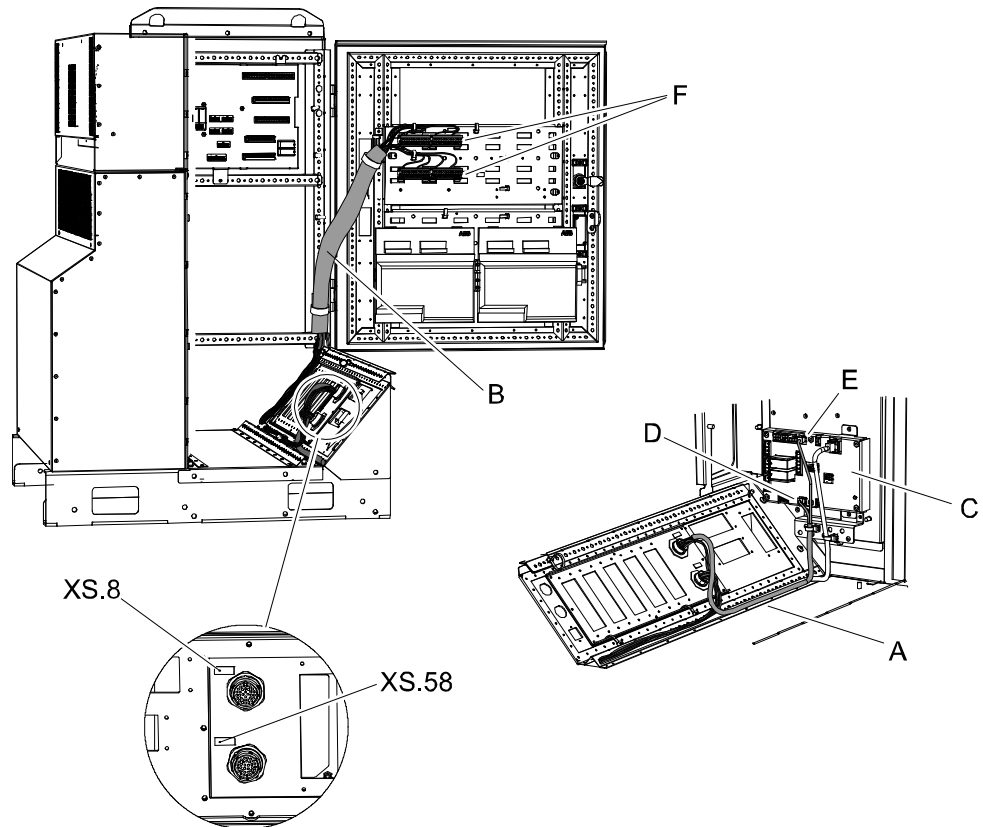

xx0600002686

A	Harness, cooling - Axis 1 and 2
B	Cable protection
C	Contactor interface board
D	Connector A43.X10
E	Connector A43.X11
F	Position switch terminals

Required equipment

Equipment	Article no.	Note
Dual Cabinet Controller, Harness, cooling - Axis 1 and 2 kit	3HAC022723-001	7m
	3HAC022723-004	15m
	3HAC022723-005	22m
	3HAC022723-006	30m
Single Cabinet Controller, Harness, cooling - Axis 1 and 2 kit	3HAC025488-001	
Standard toolkit IRC5		See Standard toolkit, IRC5 on page 299 .
Circuit diagram		See Circuit Diagram on page 319 .

Continues on next page



2 Installation and Commissioning, IRC5

2.9.9. Installation of cooling fan harness axis 1 and 2

Continued

Procedures for Dual Cabinet Controller

Following procedure details how to install the harness, cooling - Axis 1 and 2 kit in the Dual Cabinet Controller.

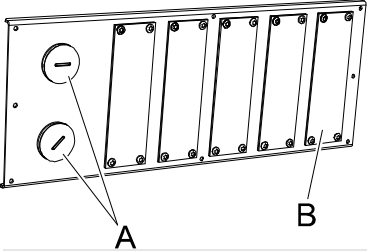
	Action	Note/Illustration
1.	 <p>DANGER! Before commencing any work inside the cabinet, please observe the safety information in section <i>DANGER - Make sure that the main power has been switched off!</i> on page 30.</p>	
2.	 <p>esd WARNING! The unit is sensitive to ESD. Before handling the unit please read the safety information in the section <i>WARNING - The unit is sensitive to ESD!</i> on page 31</p>	
3.	Remove the cover plate to an empty slot on the connection plate.	 <p>xx0500002688</p> <ul style="list-style-type: none"> • A: Sealing plug • B: Cover plate with gasket
4.	Route the harness through the empty slot.	See <i>Locations in Dual Cabinet Controller</i> on page 134.
5.	Fit the cover with cable gland.	See <i>Locations in Dual Cabinet Controller</i> on page 134.
6.	Route the harness according to the illustration in <i>Locations in Dual Cabinet Controller</i> on page 134	

© Copyright 2004-2010 ABB. All rights reserved.

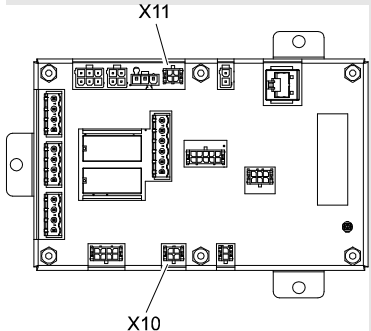

Continues on next page

Continued

Action	Note/Illustration
<p>7. Connect the harness connectors to the contactor interface board.</p> <ul style="list-style-type: none"> • A43.X11 to X11 • A43.X10 to X10 	 <p>xx0500002690 See Locations in Dual Cabinet Controller on page 134.</p>

Procedures for Single Cabinet Controller

Following procedure details how to install the harness, cooling - Axis 1 and 2 kit in the Single Cabinet Controller.

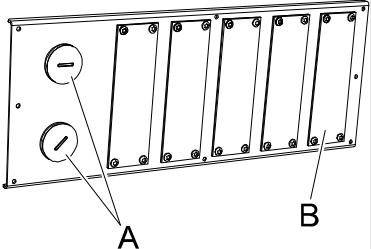
Action	Note/Illustration
<p>1.  DANGER! Before commencing any work inside the cabinet, please observe the safety information in section DANGER - Make sure that the main power has been switched off! on page 30.</p>	
<p>2.  esd WARNING! The unit is sensitive to ESD. Before handling the unit please read the safety information in the section WARNING - The unit is sensitive to ESD! on page 31</p>	
<p>3. Remove the two sealing plugs.</p>	 <p>xx</p> <ul style="list-style-type: none"> • A: Sealing plug • B: Cover plate with gasket
<p>4. Fit the two connectors XS.8 and XS.58 from the inside.</p>	<p>See Locations in Single Cabinet Controller on page 135.</p>

Continues on next page

2 Installation and Commissioning, IRC5

2.9.9. Installation of cooling fan harness axis 1 and 2

Continued

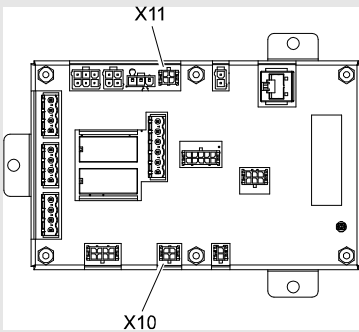
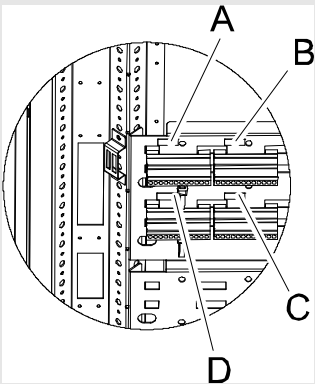
	Action	Note/Illustration
5.	Route the cable to the left and connect the harness connectors to the contactor interface board. <ul style="list-style-type: none"> • A43.X11 to X11 • A43.X10 to X10 	 <p>xx0500002690</p> <p>See Locations in Single Cabinet Controller on page 135.</p>
6.	Route the wires with terminals to be mounted on the cabinet door inside the cable protection according to the illustration.	<p>See Locations in Single Cabinet Controller on page 135.</p>
7.	Fit the snap locking terminals to the plate on the cabinet door according to the illustration.	 <p>xx0600002693</p> <ul style="list-style-type: none"> A. XT8/8.1 B. XT8/8.2 C. XP58.2 D. XP58.1 <p>See Locations in Single Cabinet Controller on page 135.</p>

2.9.10. Installation of Hot plug

Location

To be able to use the Hot plug function an additional hot plug button is needed. The figure below shows the location of the hot plug button on the Single Cabinet Controller and Dual Cabinet Controller.

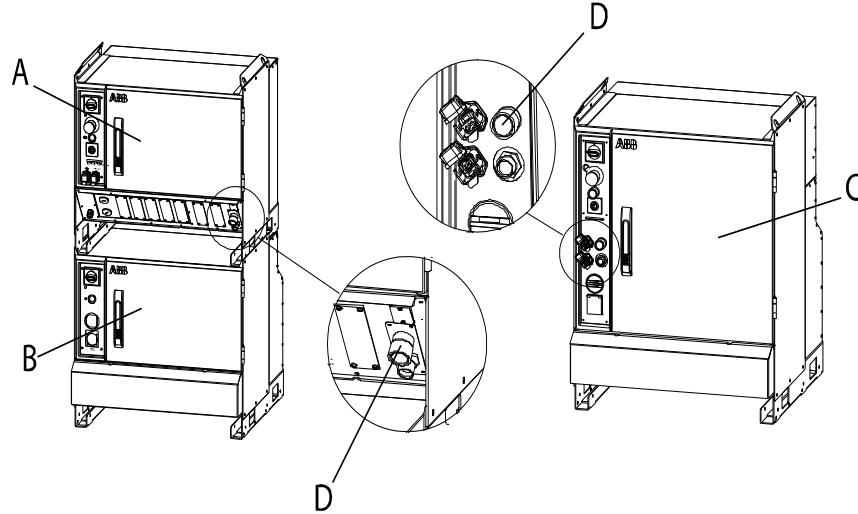

xx0600002943

A	Dual Cabinet Controller (Control Module)
B	Dual Cabinet Controller (Drive Module)
C	Single Cabinet Controller
D	Hot plug button

Required equipment

Equipment	Art. no.	Note
Hot plug	3HAC026225-002	Single Cabinet Controller
Hot plug	3HAC026225-003	Dual Cabinet Controller
Standard toolkit		The contents are defined in section <i>Standard toolkit</i> .
Other tools and procedures may be required. See references to these procedures in the step-by-step instructions below.		These procedures include references to the tools required.
Circuit diagram		See Circuit Diagram on page 319 .



2 Installation and Commissioning, IRC5

2.9.10. Installation of Hot plug

Continued

Procedure Single Cabinet Controller

The procedure below details how to install the hot plug button in the Single Cabinet Controller.

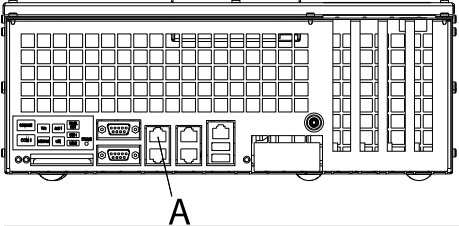
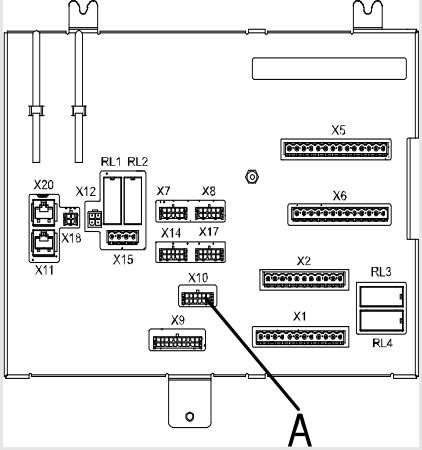
	Action	Note/Illustration
1.	 <p>DANGER! Before commencing any work inside the cabinet, please observe the safety information in section <i>DANGER - Make sure that the main power has been switched off!</i> on page 30.</p>	
2.	 <p>esd WARNING! The unit is sensitive to ESD. Before handling the unit please read the safety information in the section <i>WARNING - The unit is sensitive to ESD!</i> on page 31</p>	
3.	<p>Disconnect the cable from the ethernet connector for FlexPendant on the computer unit.</p>	<p>DSQC639:</p>  <p>xx0600002897</p> <ul style="list-style-type: none"> A: FlexPendant port
4.	<p>Disconnect signal cabling from the panel board unit.</p>	 <p>xx0600002946</p> <ul style="list-style-type: none"> A: Connector X10

© Copyright 2004-2010 ABB. All rights reserved.

Continues on next page

Continued

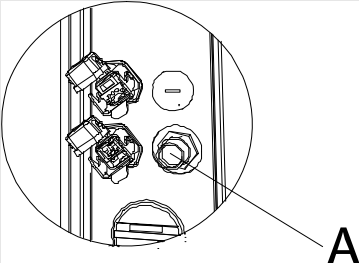
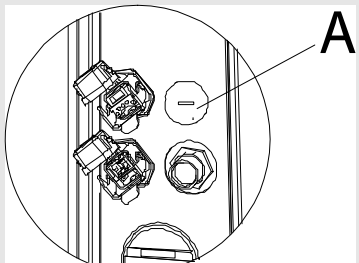
Action	Note/Illustration
<p>5. Remove the FlexPendant connector with harness from the Operator panel.</p>	 <p>xx0600002948</p> <ul style="list-style-type: none"> • A: FlexPendant connector
<p>6. Remove the plug that covers the hot plug hole.</p>	 <p>xx0600002949</p> <ul style="list-style-type: none"> • A: Plug
<p>7. Fit the new FlexPendant connector and hot plug button with harness into the empty hole on the operator panel.</p>	
<p>8. Connect the ethernet connector for FlexPendant to the computer unit.</p>	
<p>9. Connect the signal connector A21.X10 to the panel board unit.</p>	

2 Installation and Commissioning, IRC5

2.9.10. Installation of Hot plug

Continued

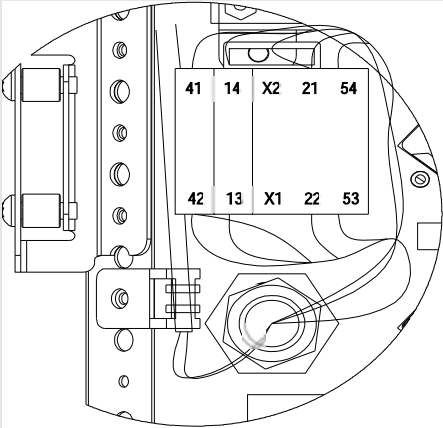
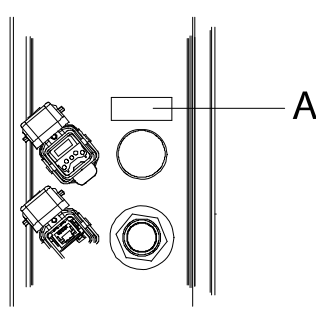

	Action	Note/Illustration																																				
10.	Connect the cables to the hot plug button connector.	 <table border="1" data-bbox="1070 824 1305 1093"> <thead> <tr> <th>Wire no.</th> <th>Conn. A</th> <th>Conn. B</th> </tr> </thead> <tbody> <tr> <td>207</td> <td>22</td> <td></td> </tr> <tr> <td>RD</td> <td>21</td> <td></td> </tr> <tr> <td>208</td> <td>42</td> <td></td> </tr> <tr> <td>OR</td> <td>41</td> <td></td> </tr> <tr> <td>209/BU</td> <td>14</td> <td></td> </tr> <tr> <td>YE/BU</td> <td>14</td> <td></td> </tr> <tr> <td>210/GN</td> <td>13</td> <td></td> </tr> <tr> <td>211/BU</td> <td>53</td> <td></td> </tr> <tr> <td>BU/BU</td> <td>X2</td> <td></td> </tr> <tr> <td>212/VT</td> <td>54</td> <td></td> </tr> <tr> <td>Bridge</td> <td>X1</td> <td>13</td> </tr> </tbody> </table> <p data-bbox="948 1099 1054 1115">xx0600002953</p>	Wire no.	Conn. A	Conn. B	207	22		RD	21		208	42		OR	41		209/BU	14		YE/BU	14		210/GN	13		211/BU	53		BU/BU	X2		212/VT	54		Bridge	X1	13
Wire no.	Conn. A	Conn. B																																				
207	22																																					
RD	21																																					
208	42																																					
OR	41																																					
209/BU	14																																					
YE/BU	14																																					
210/GN	13																																					
211/BU	53																																					
BU/BU	X2																																					
212/VT	54																																					
Bridge	X1	13																																				
11.	Place the warning label above the hot plug button.	 <p data-bbox="948 1491 1054 1507">xx0600002957</p> <ul data-bbox="986 1518 1201 1552" style="list-style-type: none"> A: Warning label 																																				
12.	Test the hot plug button function.	See section Test of hot plug button function on page 145 .																																				

© Copyright 2004-2010 ABB. All rights reserved.

Continues on next page

Procedure Dual Cabinet Controller

The procedure below details how to install the hot plug button in the Dual Cabinet Controller.

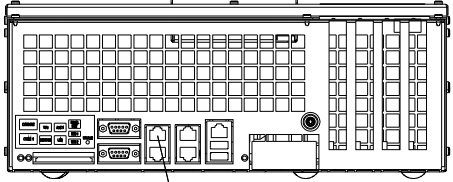
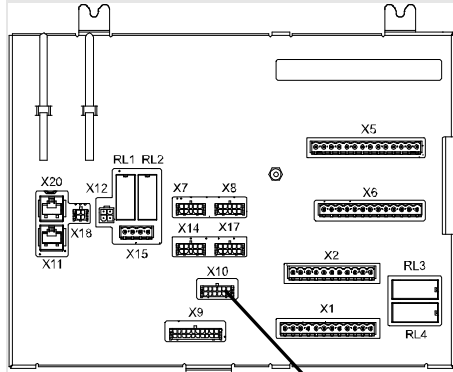
	Action	Note/Illustration
1.	 <p>DANGER! Before commencing any work inside the cabinet, please observe the safety information in section <i>DANGER - Make sure that the main power has been switched off!</i> on page 30.</p>	
2.	 <p>esd WARNING! The unit is sensitive to ESD. Before handling the unit please read the safety information in the section <i>WARNING - The unit is sensitive to ESD!</i> on page 31</p>	
3.	Disconnect the cable from the ethernet connector for FlexPendant on the computer unit.	<p>DSQC639:</p>  <p style="text-align: center;">A</p> <p>xx0600002897</p> <ul style="list-style-type: none"> A: FlexPendant port
4.	Disconnect signal cabling from the panel board unit.	 <p style="text-align: right;">A</p> <p>xx0600002946</p> <ul style="list-style-type: none"> A: Connector X10

2 Installation and Commissioning, IRC5

2.9.10. Installation of Hot plug

Continued

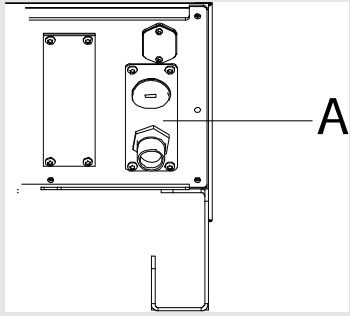
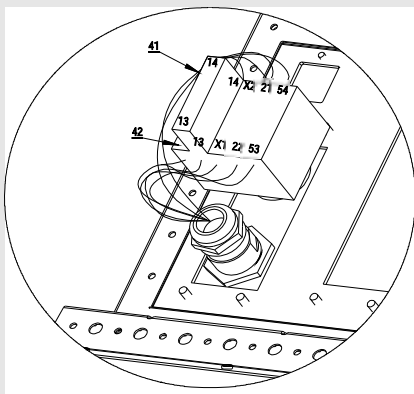
	Action	Note/Illustration																																				
	5. Remove the cover plate with the FlexPendant connector and harness.	 <p>xx0600002954</p> <ul style="list-style-type: none"> A: Cover plate 																																				
	6. Fit the new cover plate with FlexPendant connector and hot plug button with harness into the empty slot.																																					
	7. Connect the ethernet connector for FlexPendant to the computer unit.																																					
	8. Connect the signal connector A21.X10 to the panel board unit.																																					
	9. Connect the cables to the hot plug button connector.	 <table border="1" data-bbox="1050 1429 1305 1709"> <thead> <tr> <th>Wire no.</th> <th>Conn. A</th> <th>Conn. B</th> </tr> </thead> <tbody> <tr> <td>207</td> <td>22</td> <td></td> </tr> <tr> <td>214</td> <td>21</td> <td></td> </tr> <tr> <td>208</td> <td>42</td> <td></td> </tr> <tr> <td>215</td> <td>41</td> <td></td> </tr> <tr> <td>209/BU</td> <td>14</td> <td></td> </tr> <tr> <td>216/BU</td> <td>14</td> <td></td> </tr> <tr> <td>210/217</td> <td>13</td> <td></td> </tr> <tr> <td>211/BU</td> <td>53</td> <td></td> </tr> <tr> <td>218/BU</td> <td>X2</td> <td></td> </tr> <tr> <td>212/219</td> <td>54</td> <td></td> </tr> <tr> <td>Bridge</td> <td>X1</td> <td>13</td> </tr> </tbody> </table> <p>xx0600002956</p>	Wire no.	Conn. A	Conn. B	207	22		214	21		208	42		215	41		209/BU	14		216/BU	14		210/217	13		211/BU	53		218/BU	X2		212/219	54		Bridge	X1	13
Wire no.	Conn. A	Conn. B																																				
207	22																																					
214	21																																					
208	42																																					
215	41																																					
209/BU	14																																					
216/BU	14																																					
210/217	13																																					
211/BU	53																																					
218/BU	X2																																					
212/219	54																																					
Bridge	X1	13																																				

© Copyright 2004-2010 ABB. All rights reserved.

Continues on next page

Continued

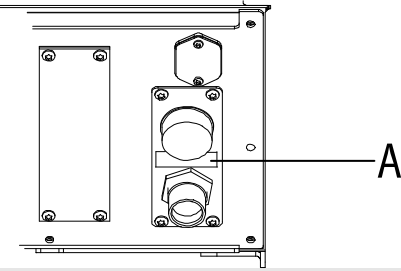
	Action	Note/Illustration
10.	Place the warning label below the hot plug button.	 <p>xx0600002955</p> <ul style="list-style-type: none"> A: Warning label
11.	Test the hot plug button function.	See section Test of hot plug button function on page 145 .

Test of hot plug button function

The procedure below details how to test the hot plug button function.

	Action	Note/Illustration
1.	Make sure that the system is in automatic mode.	
2.	Press the motors on button.	
3.	Press and hold the hot plug button. <ul style="list-style-type: none"> Verify that the red lamp indicates when actuated. Verify that the system still has motors on. 	
4.	Keep pressing the hot plug button and at the same time, switch the jumper plug with the FlexPendant plug. <ul style="list-style-type: none"> Verify that the system still has motors on. 	
5.	Release the hot plug button. <ul style="list-style-type: none"> Verify that the system still has motors on. 	Make sure that the button is not stuck in the actuated position since it disables the FlexPendant emergency stop button.
6.	Press and hold the hot plug button.	
7.	Keep pressing the hot plug button and at the same time, switch the FlexPendant plug with the jumper plug.	
8.	Release the hot plug button. <ul style="list-style-type: none"> Verify that the FlexPendant starts up correctly. Verify that the system still has motors on. 	
9.	Switch to Manual mode.	Motors off
10.	Confirm the mode change. <ul style="list-style-type: none"> Verify motors on. 	
11.	Press the hot plug button. <ul style="list-style-type: none"> Verify motors off. 	

2 Installation and Commissioning, IRC5

2.9.11. Installing the EPS board DSQC 646 for Electronic Position Switches

2.9.11. Installing the EPS board DSQC 646 for Electronic Position Switches

General

To use the option Electronic Position Switches you need to install an EPS board in the robot controller. The procedure below will show how to install this board.



NOTE!

It is not possible to have the options EPS and SafeMove installed at the same time - that is, only one of these two options can be installed and used.



WARNING!

The safety controller has passive monitoring, i.e. it does not stop the robot. If an axis is outside its configured range, an output signal goes low. It is the responsibility of the installation personnel to connect the output signals in such a way that the robot is stopped if there is a risk of a dangerous situation.

Illustration

The EPS board should be mounted behind the axis computer.

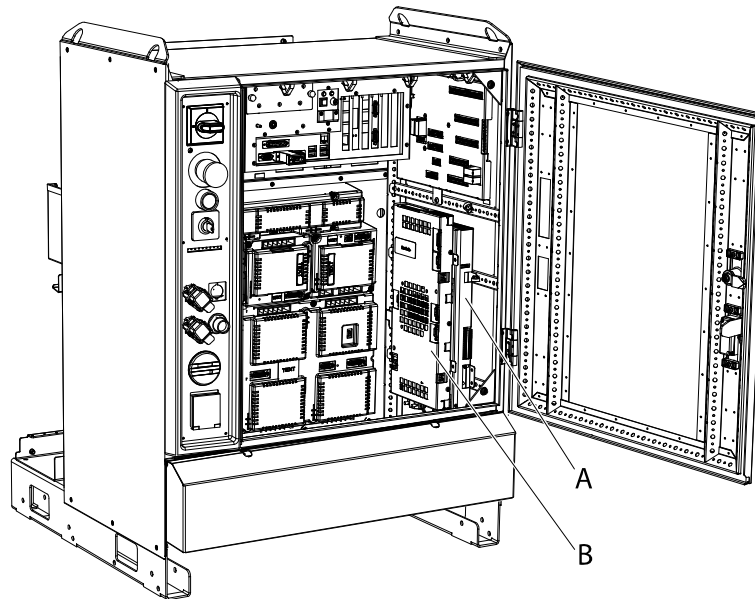



xx0600003203

A	EPS board
B	Axis computer

Procedure

The procedure below details how to install an EPS board.

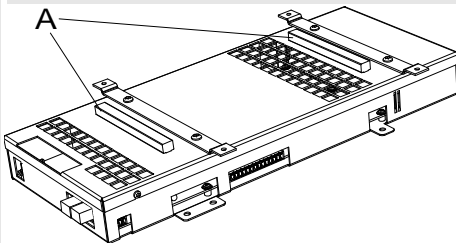
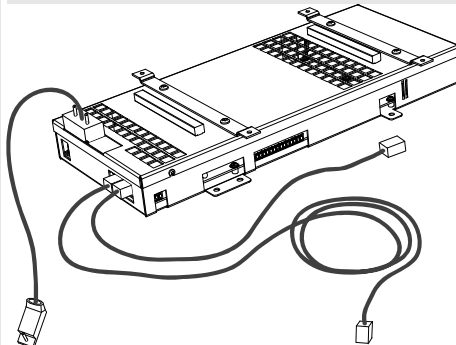
	Action	Note/illustration
1.	 <p>DANGER! Before commencing any work inside the cabinet, please observe the safety information in section <i>DANGER - Make sure that the main power has been switched off!</i> on page 30.</p>	
2.	 <p>esd</p> <p>WARNING! The unit is sensitive to ESD. Before handling the unit please read the safety information in the section <i>WARNING - The unit is sensitive to ESD!</i> on page 31</p>	
3.	<p>If not already in place, fit the EMC strips on the EPS board.</p>	 <p style="text-align: center; font-size: small;">xx0700000087</p>
4.	<p>Connect the short SMB cable and both Ethernet cables to the EPS board before mounting the board. These connections may be difficult to reach once the board is mounted.</p> <p>The two Ethernet connectors on the EPS board are interchangeable (it does not matter which is connected to the main computer and which is connected to the axis computer).</p>	 <p style="text-align: center; font-size: small;">xx0600003303</p>

2 Installation and Commissioning, IRC5

2.9.11. Installing the EPS board DSQC 646 for Electronic Position Switches

Continued

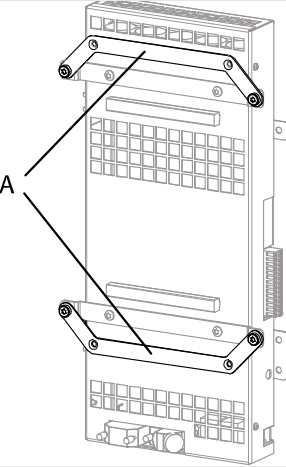
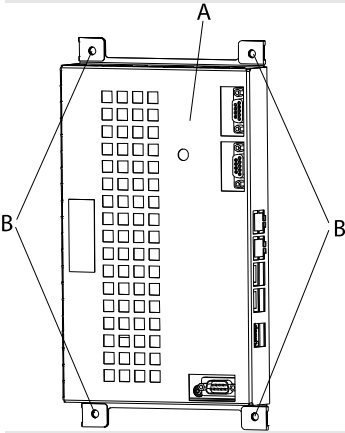
Action	Note/illustration
5. If the EPS board is used together with axis computer DSQC 668 (used with Drive System 09) two mounting brackets must be mounted on the EPS board. These are necessary to be able to mount the axis computer (see step 9).	 <p>xx0900000436</p> <ul style="list-style-type: none">A: Mounting brackets
6. Remove the attachment screws of the axis computer. Lift out the axis computer so that the EPS board can be fitted behind the axis computer.	 <p>xx0900000030</p> <ul style="list-style-type: none">A: axis computerB: attachment screws

© Copyright 2004-2010 ABB. All rights reserved.

Continues on next page

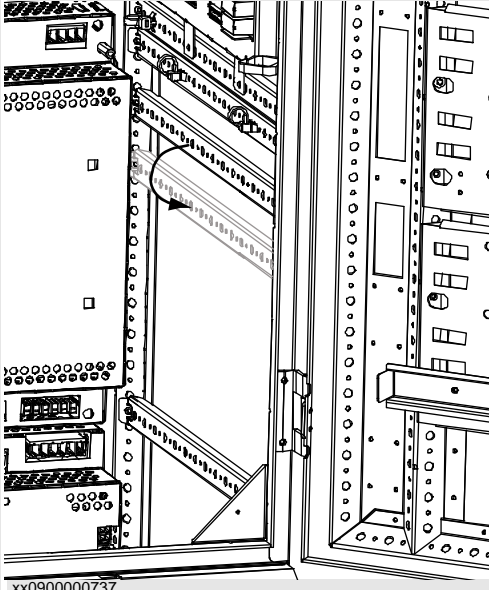
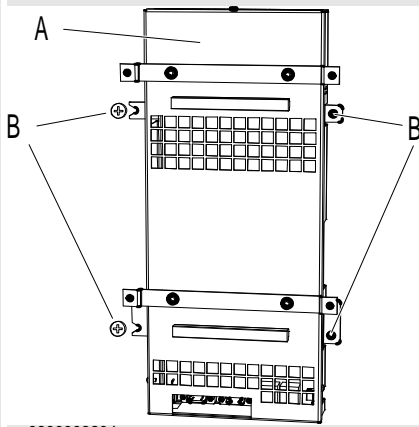
Action	Note/illustration
<p>7. If the EPS board is used together with axis computer DSQC 668 (used with Drive System 09), the upper mounting rail must be moved:</p> <ol style="list-style-type: none"> 1. Remove the Main Drive Unit. See Replacement of drive units (Drive System 09) on page 229. 2. Move the upper mounting rail two steps (50 mm) down. 3. Replace the Main Drive Unit. 	 <p style="text-align: right; font-size: small;">xx0900000737</p>
<p>8. Fit the EPS board in the same place as the axis computer was before.</p>	 <p style="text-align: right; font-size: small;">xx0600003204</p> <ul style="list-style-type: none"> • A: EPS board • B: attachment screws

2 Installation and Commissioning, IRC5

2.9.11. Installing the EPS board DSQC 646 for Electronic Position Switches

Continued

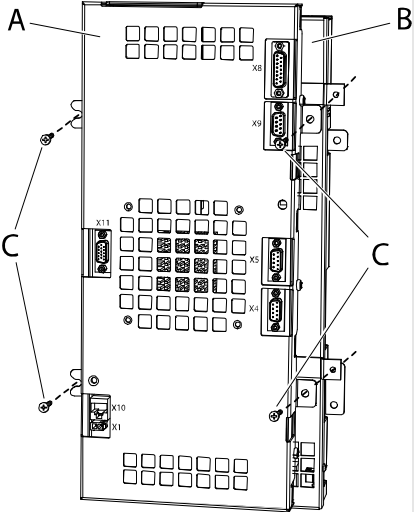
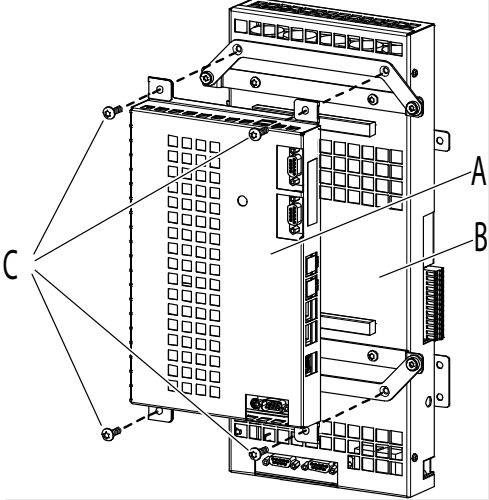
Action	Note/illustration
9. Fit the axis computer on the EPS board.	<p data-bbox="919 322 1394 353">Axis computer DSQC 601 (Drive System 04):</p>  <p data-bbox="919 875 1026 896">xx0600003206</p> <ul data-bbox="956 902 1230 999" style="list-style-type: none">• A: axis computer• B: EPS board• C: attachment screws <p data-bbox="919 1041 1394 1072">Axis computer DSQC 668 (Drive System 09):</p>  <p data-bbox="919 1574 1026 1594">xx0900000438</p> <ul data-bbox="956 1601 1230 1697" style="list-style-type: none">• A: axis computer• B: EPS board• C: attachment screws

© Copyright 2004-2010 ABB. All rights reserved.

Continues on next page

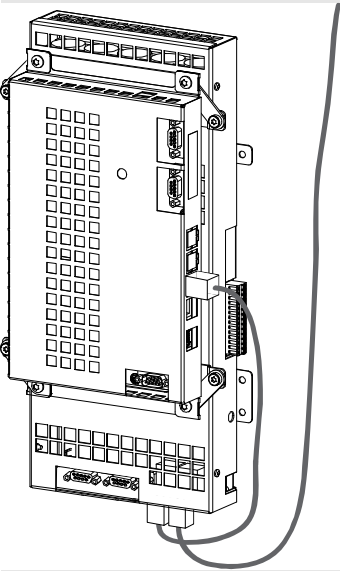
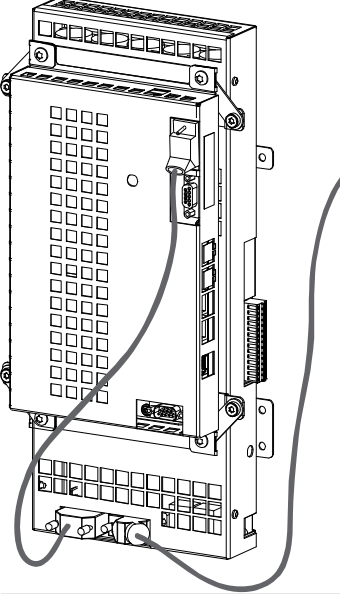
	Action	Note/illustration
10.	<p>For a Single Cabinet Controller: Remove the Ethernet cable between the main computer and the axis computer. Replace it with the long Ethernet cable from the EPS board to the main computer. Connect the short Ethernet cable between the EPS board and the axis computer.</p> <p>For a Drive Module: Remove the existing Ethernet cable from the axis computer and connect it to the EPS board. Connect the short Ethernet cable between the EPS board and the axis computer.</p>	 <p style="text-align: right; font-size: small;">xx0600003218</p>
11.	<p>Remove the SMB cable from the axis computer and connect it to the EPS board. Connect the SMB cable from the EPS board to the axis computer.</p>	 <p style="text-align: right; font-size: small;">xx0600003207</p>

2 Installation and Commissioning, IRC5

2.9.11. Installing the EPS board DSQC 646 for Electronic Position Switches

Continued

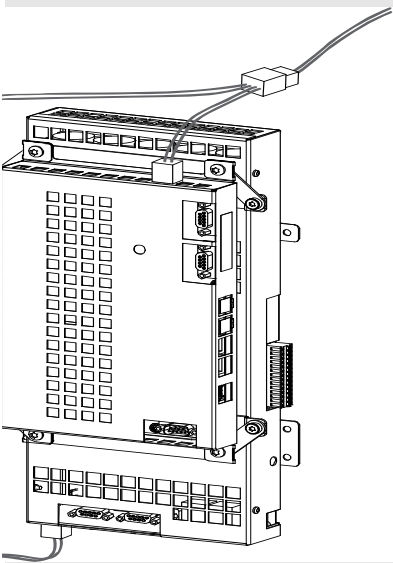
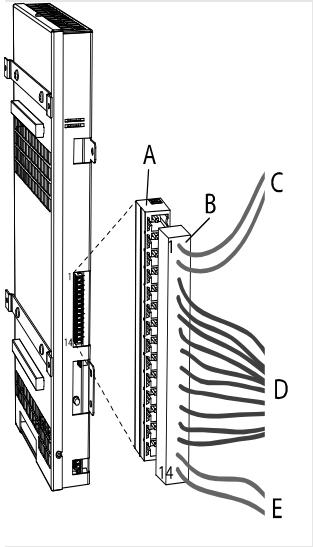
	Action	Note/illustration
12.	<p>Remove the power cable from the axis computer and connect it to the split cable.</p> <p>Connect the split cable to the EPS board and the axis computer.</p>	 <p>xx0600003208</p>
13.	<p>Connect signal cables to the plug contact, which is then connected to the I/O connector of the EPS board.</p> <ul style="list-style-type: none">• Connect a power supply, 24 V to pin 1 and 0 V to pin 2. Check with a voltmeter that the voltage is 24 V between pin 1 and 2 on the Phoenix connector.• Connect the output signals from the EPS board (pin 3-12).• Connect the sync switch signals to pin 13 and 14. If dual channel wiring is not used, connect only pin 14.	 <p>xx0600003209</p> <ul style="list-style-type: none">• A: I/O Connector• B: Plug contact• C: Power supply• D: 5 safe outputs (10 signals)• E: Sync switch (dual signal)

2.9.12. Installing the SafeMove board DSQC 647

General

To use the option SafeMove you need to install an SafeMove board DSQC 647 in the robot controller. The procedure below will show how to install this board.



NOTE!

It is not possible to have the options SafeMove and EPS installed at the same time - that is, only one of these two options can be installed and used.

Location

The SafeMove board should be mounted behind the axis computer.

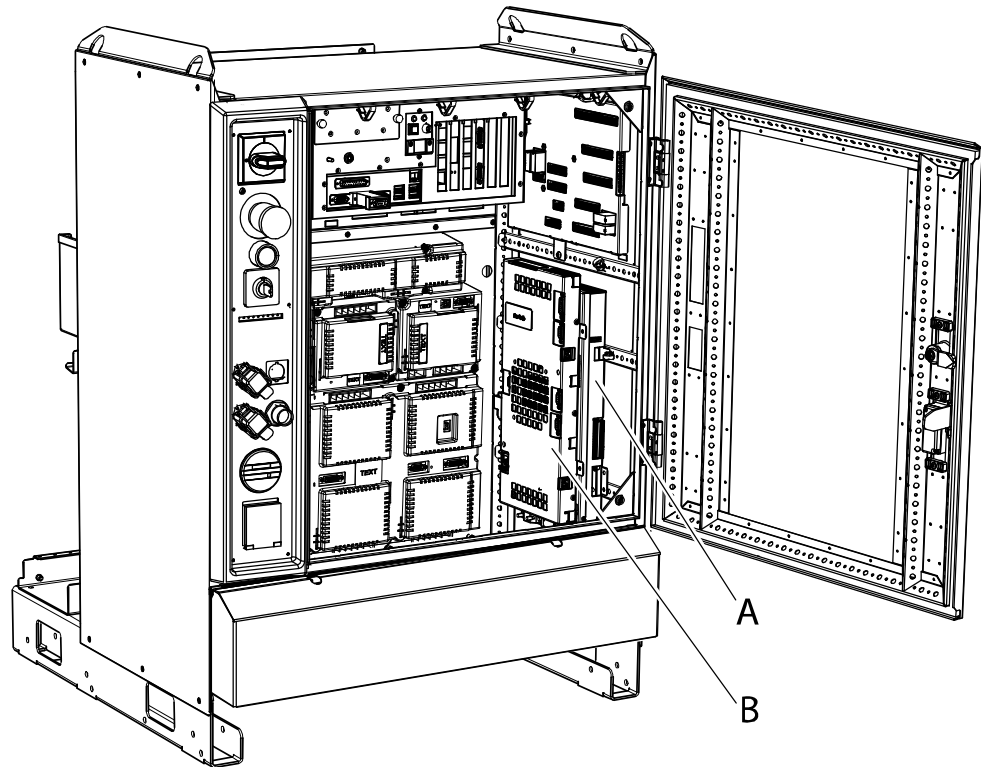

xx0800000102

A	SafeMove board
B	Axis computer

2 Installation and Commissioning, IRC5

2.9.12. Installing the SafeMove board DSQC 647

Continued

Procedure

The procedure below details how to install the SafeMove board.

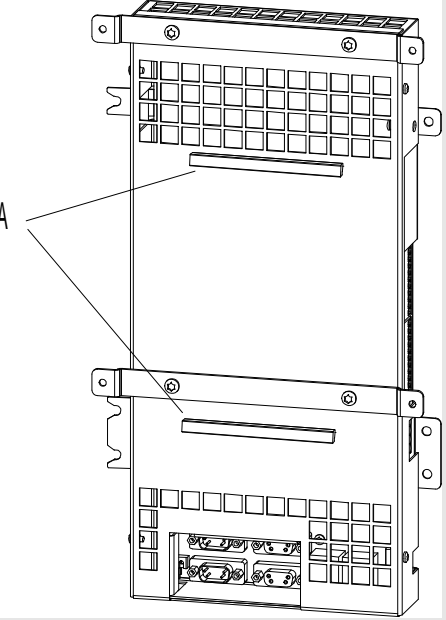
	Action	Note/illustration
1.	 DANGER! Before commencing any work inside the cabinet, please observe the safety information in section <i>DANGER - Make sure that the main power has been switched off!</i> on page 30.	
2.	WARNING! The unit is sensitive to ESD, before handling the unit please observe the safety information in section <i>Warning - The unit is sensitive to ESD!</i> on page 27.	
3.	If not already in place, fit the EMC strips on the SafeMove board.	 <p>xx0800000204</p> <ul style="list-style-type: none">A: EMC strips

© Copyright 2004-2010 ABB. All rights reserved.

Continued

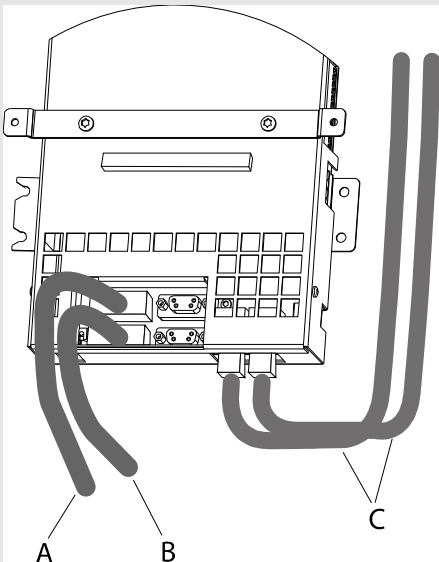
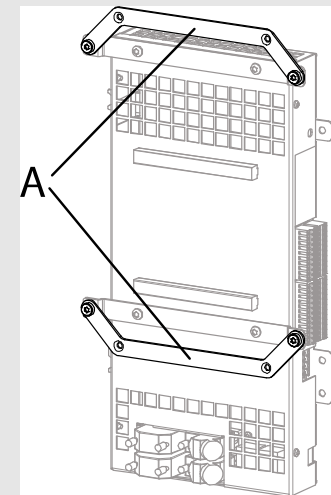
Action	Note/illustration
<p>4. Connect both SMB cables and both Ethernet cables to the SafeMove board before mounting the board. These connections may be difficult to reach once the board is mounted.</p> <p>The two Ethernet connectors on the SafeMove board are interchangeable (it does not matter which is connected to the main computer and which is connected to the axis computer).</p>	 <p>xx0800000103</p> <ul style="list-style-type: none"> • A: SMB1 cable • B: SMB2 cable • C: Ethernet cables
<p>5. If the SafeMove board is used together with axis computer DSQC 668 (used with Drive System 09) two mounting brackets must be mounted on the SafeMove board. These are necessary to be able to mount the axis computer (see step 9).</p>	 <p>xx0900000439</p>

2 Installation and Commissioning, IRC5

2.9.12. Installing the SafeMove board DSQC 647

Continued

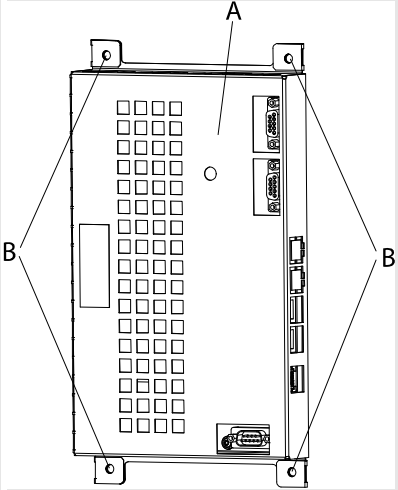
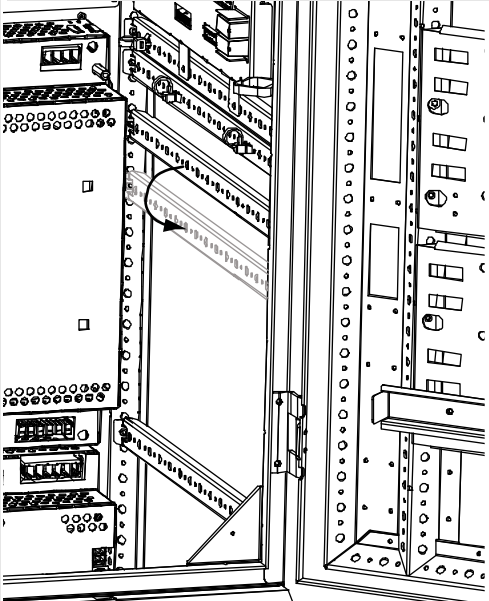
Action	Note/illustration
6. Remove the attachment screws of the axis computer. Lift out the axis computer so that the SafeMove board can be fitted behind the axis computer.	 <p>xx0900000030</p> <ul style="list-style-type: none">• A: axis computer• B: attachment screws (4 pcs)
7. If the SafeMove board is used together with axis computer DSQC 668 (used with Drive System 09), the upper mounting rail must be moved: <ol style="list-style-type: none">1. Remove the Main Drive Unit. See Replacement of drive units (Drive System 09) on page 229.2. Move the upper mounting rail two steps (50 mm) down.3. Replace the Main Drive Unit.	 <p>xx0900000737</p>

© Copyright 2004-2010 ABB. All rights reserved.

Continues on next page

Continued

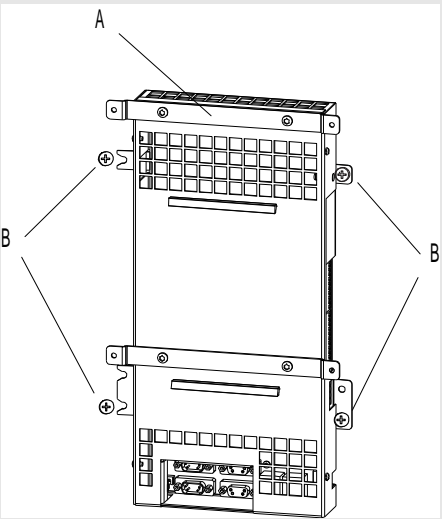
	Action	Note/illustration
	8. Fit the SafeMove board in the same place as the axis computer was before.	 <p>xx0800000104</p> <ul style="list-style-type: none">• A: SafeMove board• B: attachments screws (4 pcs)

2 Installation and Commissioning, IRC5

2.9.12. Installing the SafeMove board DSQC 647

Continued

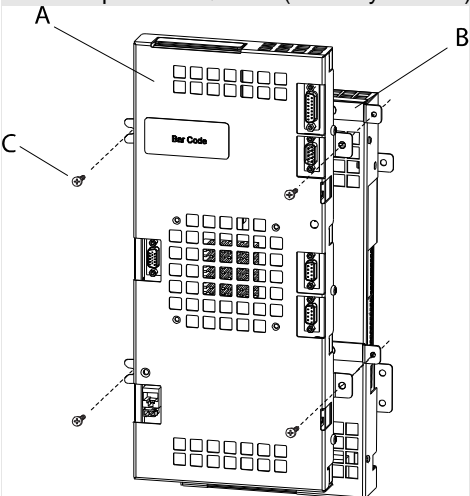
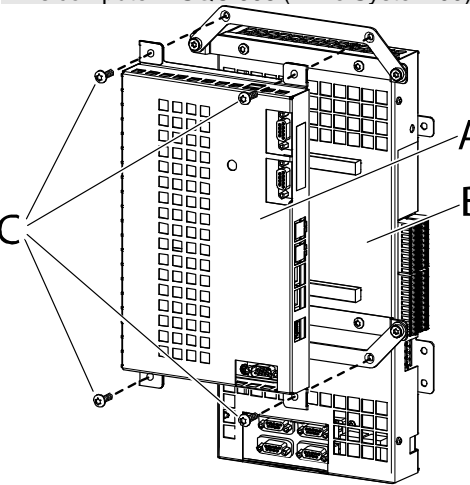
Action	Note/illustration
9. Fit the axis computer on the SafeMove board.	<p>Axis computer DSQC 601 (Drive System 04):</p>  <p>xx080000017</p> <ul style="list-style-type: none">• A: Axis computer• B: SafeMove board• C: attachment screws (4 pcs) <p>Axis computer DSQC 668 (Drive System 09):</p>  <p>xx0900000441</p> <ul style="list-style-type: none">• A: Axis computer• B: SafeMove board• C: attachment screws (4 pcs)

© Copyright 2004-2010 ABB. All rights reserved.

Continues on next page

Continued

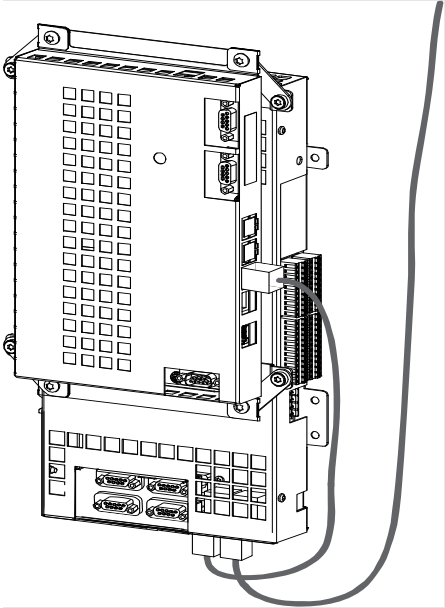
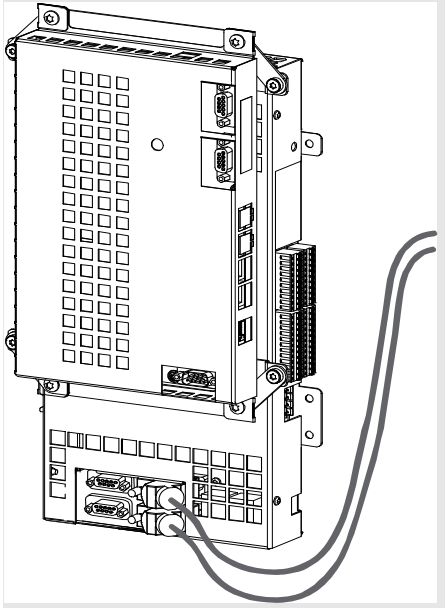
	Action	Note/illustration
10.	<p>For a Single Cabinet Controller: Remove the Ethernet cable between the main computer and the axis computer. Replace it with the long Ethernet cable from the SafeMove board to the main computer. Connect the short Ethernet cable between the SafeMove board and the axis computer.</p> <p>For a Dual Cabinet Controller, Drive Module: Disconnect the Ethernet cable from the axis computer and connect it to the SafeMove board. Connect the short Ethernet cable between the SafeMove board and the axis computer.</p>	 <p>xx0800000018</p>
11.	<p>Disconnect the SMB cables from the axis computer and connect them to the SafeMove board.</p>	 <p>xx0800000031</p> <ul style="list-style-type: none"> • A: SMB1 cable (robot) • B: SMB2 cable (external axes)

2 Installation and Commissioning, IRC5

2.9.12. Installing the SafeMove board DSQC 647

Continued

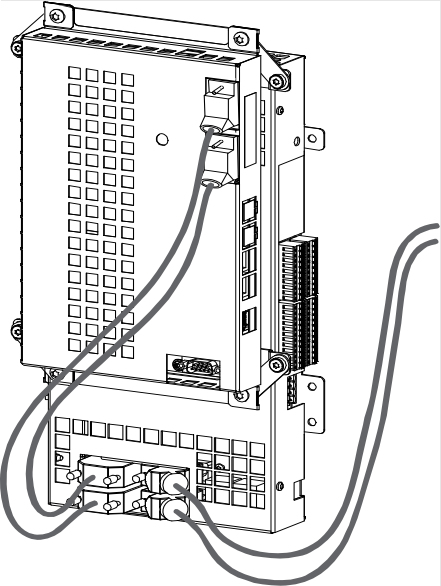
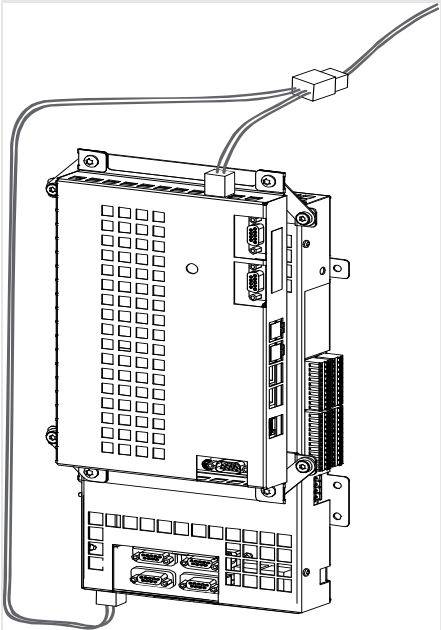
	Action	Note/illustration
12.	Connect the SMB cables from the SafeMove board to the axis computer	 <p>xx080000032</p> <ul style="list-style-type: none">• A: SMB1 cable• B: SMB2 cable
13.	Disconnect the power cable from the axis computer and connect it to the split cable. Connect the split cable to the SafeMove board and the axis computer.	 <p>xx080000028</p>

© Copyright 2004-2010 ABB. All rights reserved.

Continues on next page

Continued

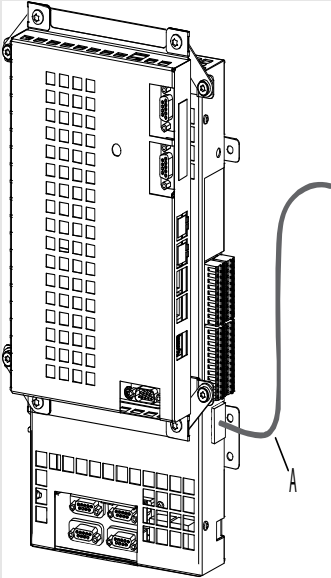
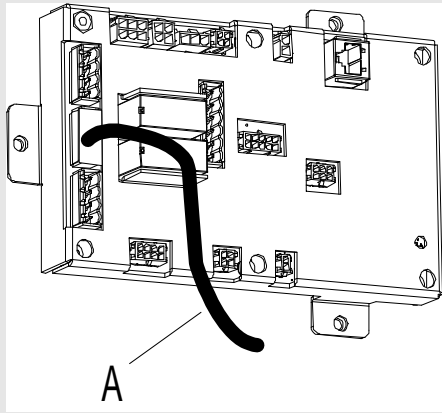
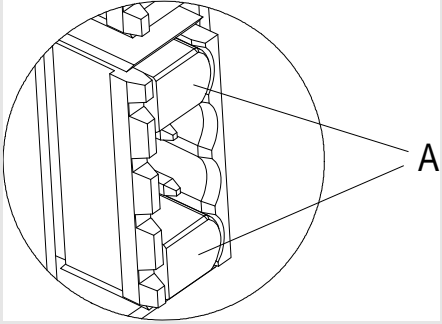
	Action	Note/illustration
	<p>14. Connect the limit switch cable between the SafeMove board (X13) and the contactor interface board (X21)</p>	<p>SafeMove board:</p>  <p>xx080000033</p> <p>Contactor interface board:</p>  <p>xx0800000105</p> <ul style="list-style-type: none"> • A: limit switch cable
	<p>15. Mount the plugs in the limit switch override contact (X23) at pin 1 and 4 on the contactor interface board.</p>	<p>The limit switch override contact must be plugged and not used when using SafeMove.</p>  <p>xx0800000035</p> <ul style="list-style-type: none"> • A: plug (2pcs)

2 Installation and Commissioning, IRC5

2.9.12. Installing the SafeMove board DSQC 647

Continued

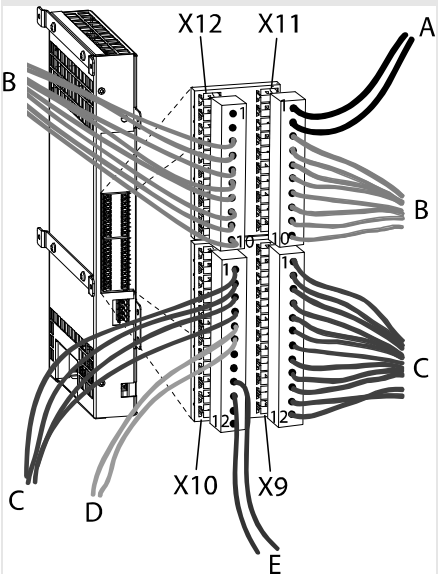
Action	Note/illustration
16. Connect signal cables to the plug contacts, which is then connected to the I/O connector of the SafeMove board.	 <p data-bbox="917 929 1029 952">xx0700000640</p> <ul data-bbox="949 952 1356 1142" style="list-style-type: none">• A: Power supply• B: 8 safe outputs (16 signals)• C: 8 safe inputs (16 signals)• D: Sync switch (dual signal)• E: Override operation input (dual signal)

2.9.13. Installation of Remote Service

General

To use the option Remote Service you need a Remote Service box mounted in the robot controller. The procedure below will show how to connect the Remote Service antenna.

Location

The illustration below shows the Remote Service box in the Single Cabinet Controller. For Dual Cabinet Controller the Remote Service box is located on the bottom of the Control Module.

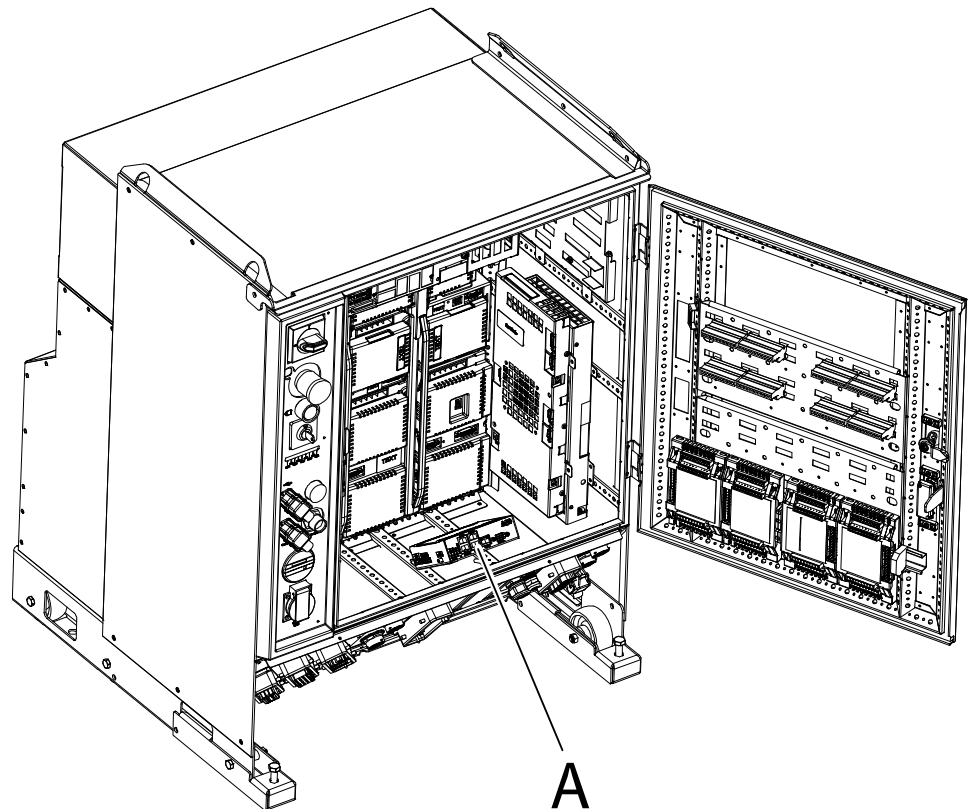

xx080000094

A	Remote Service box
---	--------------------

2 Installation and Commissioning, IRC5

2.9.13. Installation of Remote Service

Continued

Procedure

The following procedure details how to connect the Remote Service antenna.

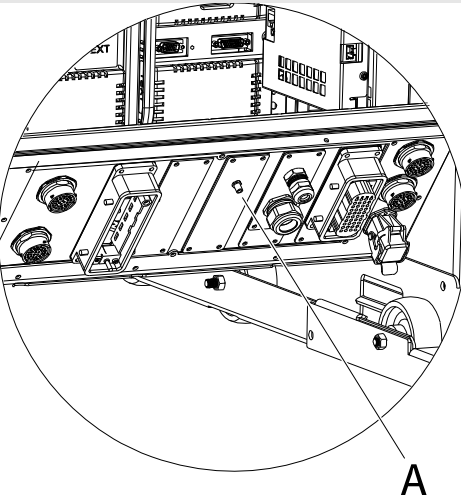
Action	Note/illustration
1. Connect the antenna cable to the adapter cover plate on the controller. Use tightening torque 0.8 - 1.1 Nm.	 <p>xx0800000095</p> <ul style="list-style-type: none">A: Antenna connector
2. Place the antenna on top of the controller.	

2.9.14. Installation of DispensePac support

About DispensePac

To use the DispensePac option you need to connect externally placed Process I/O board(s). The procedure below shows how to connect the DeviceNet cable from the Process I/O board to the DeviceNet signal cable from the Process Interface Board.

Location

The illustration below shows the location of the Process Interface Board and the connection point of the DeviceNet cable(s).

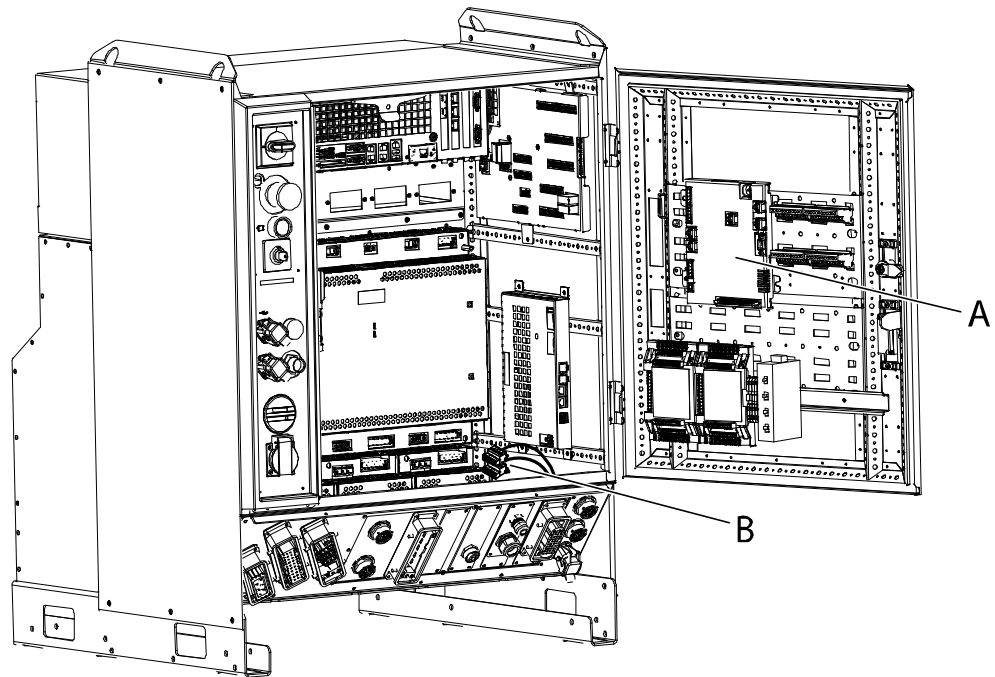

xx0900000130

A	Process Interface Board
B	A57.X1 and A57.X2 DeviceNet connectors

Connecting Process I/O boards

	Action	Note
1.	The DeviceNet cable from the Process I/O board (not included in the DispensePac support option) is connected (without termination resistance) to the DeviceNet cable, marked A57.XT1/XT2, from the Process Interface Board. Information about connection of the leaders is found in the Circuit diagram 3HAC024480-004	The connectors A57.XT1 and A57.XT2 are found on the bottom of the Controller cabinet, at the end of the cable from the Process Interface Board.
2.	If a second Process I/O board is to be connected, remove the termination resistance on the second cable and connect the second Process I/O board to this cable.	

2.9.14. Installation of DispensePac support

3 Maintenance activities, controller IRC5

3.1. Maintenance schedule, controller IRC5

General

The IRC5 robot controller must be maintained at regular intervals to ensure its function. The maintenance activities and their respective intervals are specified below:

Intervals

Equipment	Maintenance activity	Interval	Note!	Detailed in section:
Complete controller modules	Inspection	12 months *		<i>Inspection of the controller on page 168.</i>
Moist dust filter	Cleaning			<i>Cleaning moist dust filter on page 175</i>
Moist dust filter	Replacement	24 months *		<i>Replacement of moist dust filter on page 171</i>
Heat exchanger fan	Inspection	6 months *		<i>Inspection of the controller on page 168.</i>
Heat exchanger fan	Cleaning	12 months *		<i>Cleaning of the controller cabinet on page 174.</i>
FlexPendant	Cleaning	When needed		<i>Cleaning the FlexPendant on page 176.</i>
Earth Fault Breaker	Testing	6 months	Contact ABB for more information	

*) The time interval depends on the working environment of the equipment: a cleaner environment may extend the maintenance interval and vice versa.

3 Maintenance activities, controller IRC5

3.2.1. Inspection of the controller

3.2 Inspection activities

3.2.1. Inspection of the controller

Inspection

The procedure below describes how to inspect the IRC5 controller.

WARNING!

Please observe the following before commencing any repair work on the IRC5 Controller modules or units connected to the controller:

- Switch off all electric power supplies with the power switches on the Control and Drive modules!
- Before handling, make sure you are grounded through a special ESD wrist bracelet or similar. Many components inside the module are sensitive to ESD (ElectroStatic Discharge) and can be destroyed if exposed to discharge. See the Safety chapter, *WARNING - The unit is sensitive to ESD! on page 31*

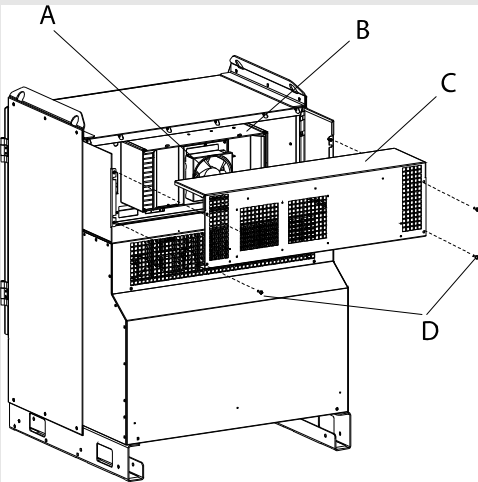

	Action	Note/Illustration
1.	Inspect all sealing joints and cable glands to make sure they are airtight in order to prevent dust and dirt from penetrating into the controller.	
2.	Inspect connectors and cabling to make sure they are securely fastened and cabling not damaged.	
3.	Inspect the heat exchanger and the fan on the controller to make sure it is clean.	 <p>xx0500001952</p> <p>Parts:</p> <ul style="list-style-type: none">• A: fan• B: heat exchanger• C: top cover• D: attachment screw (4 pcs)

© Copyright 2004-2010 ABB. All rights reserved.

Continues on next page

Continued

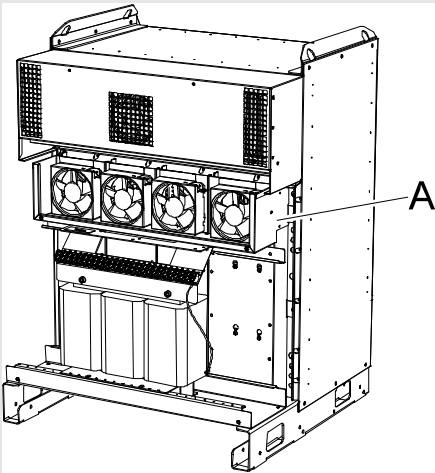
	Action	Note/Illustration
4.	Inspect the drive system fans and air channels in the controller to make sure they are clean.	 <p>xx0500002172</p> <ul style="list-style-type: none"> • A: drive system fans (4 pcs)
5.	After cleaning: Temporarily turn the power supply to the modules on. Inspect all fans to make sure they function correctly. Turn the power supply back off.	Replace any malfunctioning fans as detailed in the Replacement of heat exchange unit and fan on page 196 or Replacement of drive system fans on page 255 .

3.3.1. Activities

3.3 Changing/replacing activities

3.3.1. Activities

References

Certain activities to be performed as specified in the Maintenance Schedule are not all detailed in this chapter, but in the Repair chapter.

Please refer to the Repair chapter of the equipment in question.

3.3.2. Replacement of moist dust filter

Location

The moist dust filters are located as shown in the illustration below.

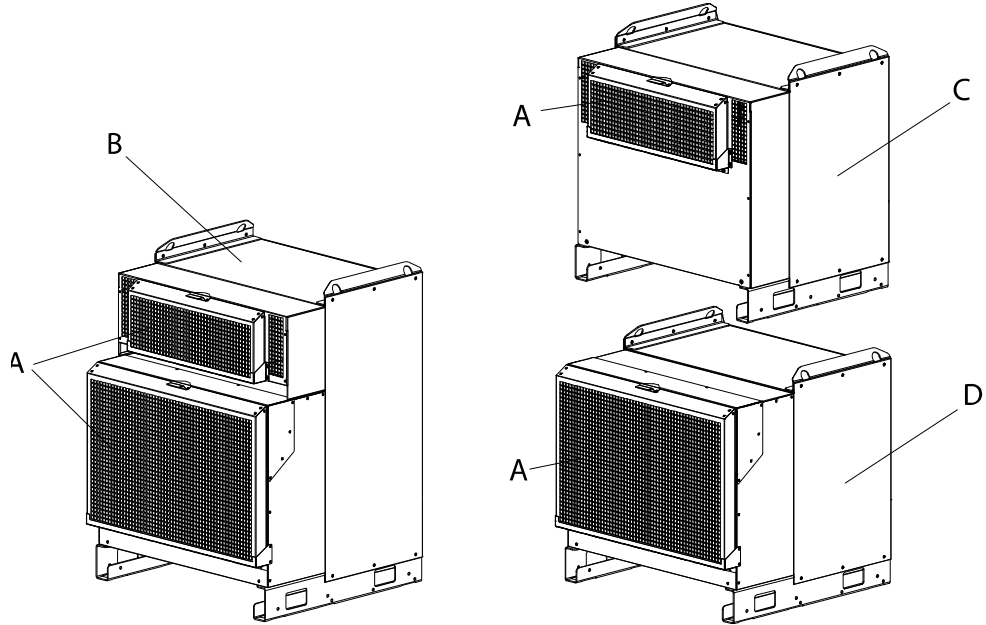

xx070000128

A	Moist dust filter magazine
B	Single Cabinet Controller
C	Dual Cabinet Controller, Control Module
D	Dual Cabinet Controller, Drive Module

Required equipment

Equipment	Note
Moist dust filter	
Other tools and procedures may be required. See references to these procedures in the step-by-step instructions below.	These procedures include references to the tools required.

3 Maintenance activities, controller IRC5

3.3.2. Replacement of moist dust filter

Continued

Removal

The procedure below details how to replace the moist dust filter.

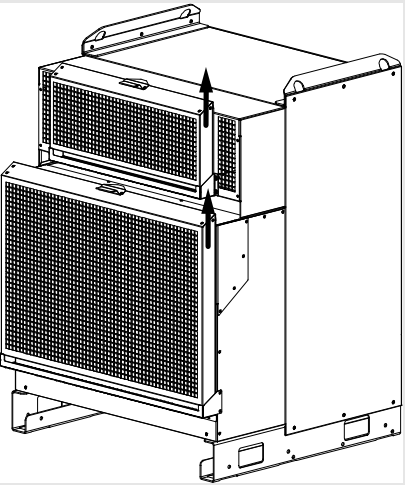
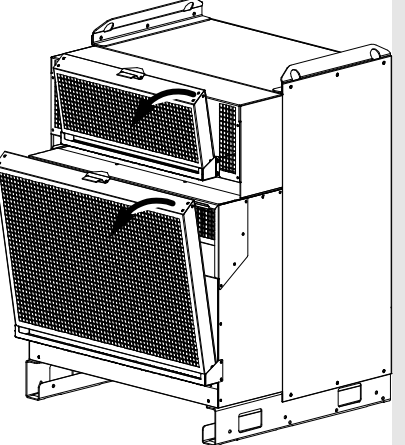
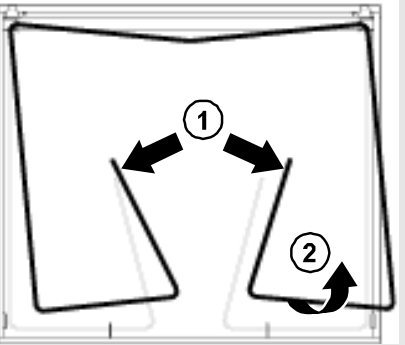
Action	Note/Illustration
1. Pull the moist dust filter magazine upwards.	 <p>xx0700000131</p>
2. Pull the moist dust filter magazine in the arrow direction and remove it.	 <p>xx0700000132</p>
3. Remove the old moist dust filter by releasing the lock shackle and lifting it.	 <p>xx0200000003</p>

© Copyright 2004-2010 ABB. All rights reserved.

Continues on next page

Refitting

The procedure below details how to refit the moist dust filter.

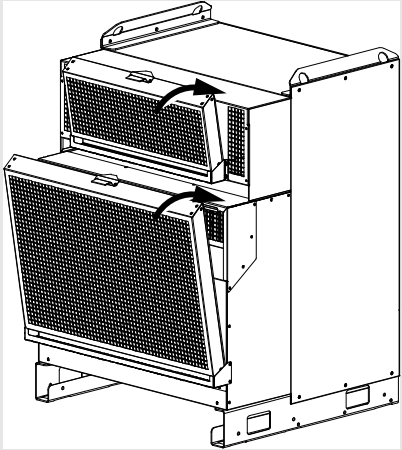
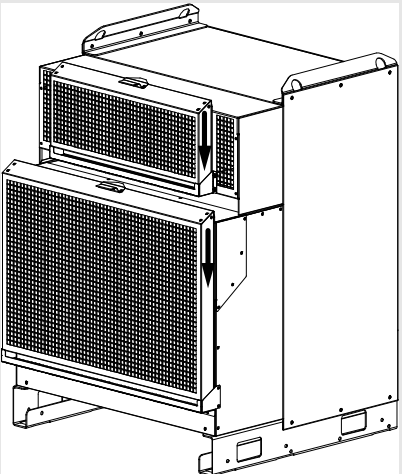
Action	Note/Illustration
<p>1. Fit the new moist dust filter in the magazine and lock it with the lock shackle.</p> <p></p> <p>NOTE! The compact surface on the moist dust filter must be turned inwards to the cabinet.</p>	
<p>2. Fit the moist dust filter magazine on the cabinet and push inwards.</p>	 <p>xx0700000134</p>
<p>3. Push the moist dust filter magazine downwards until it stops.</p>	 <p>xx0700000135</p>

3 Maintenance activities, controller IRC5

3.4.1. Cleaning of the controller cabinet

3.4 Cleaning activities

3.4.1. Cleaning of the controller cabinet

Required equipment

Equipment, etc.	Note
Vacuum cleaner	ESD Protected
Cleaning agent, exterior cleaning	If necessary, use rag with e.g. alcohol

Internal cleaning

The procedure below details how to clean the interior of the Control and Drive Module

	Action	Note/Illustration
1.	Clean the cabinet interior with a vacuum cleaner if necessary.	
2.	The control module is equipped with a heat exchanger, it is important that it is clean. The heat exchanger is found: <ul style="list-style-type: none">on the rear of the controller.	If required, remove any heat exchangers before cleaning as detailed in the section, Replacement of heat exchange unit and fan on page 196.
3.	The controller is equipped with air channels. To clean the channels: <ul style="list-style-type: none">Remove the drive module fans and use compressed air to clean the channels.	How to remove the fans is detailed in section, Replacement of drive system fans on page 255.
4.	If the IRC5 controller is installed in a very harsh environment, the drive units cooling fans must be cleaned at regular intervals.	How to remove the drive units is detailed in section, Replacement of servo drive units, rectifier and capacitor unit (Drive System 04) on page 226

Do's and don'ts!

The section below specifies some special considerations when cleaning the controller.

Always:

- use ESD Protection
- use cleaning equipment as specified above! Any other cleaning equipment may shorten the life of paintwork, rust inhibitors, signs, or labels!
- check that all protective covers are fitted to the controller before cleaning!

Never:

- remove any covers or other protective devices when cleaning the outside of the controller!
- use compressed air or spray with a high pressure cleaner!
- leave the door open when cleaning exterior

3.4.2. Cleaning moist dust filter

Location

The moist dust filters are located as shown in the illustration below.

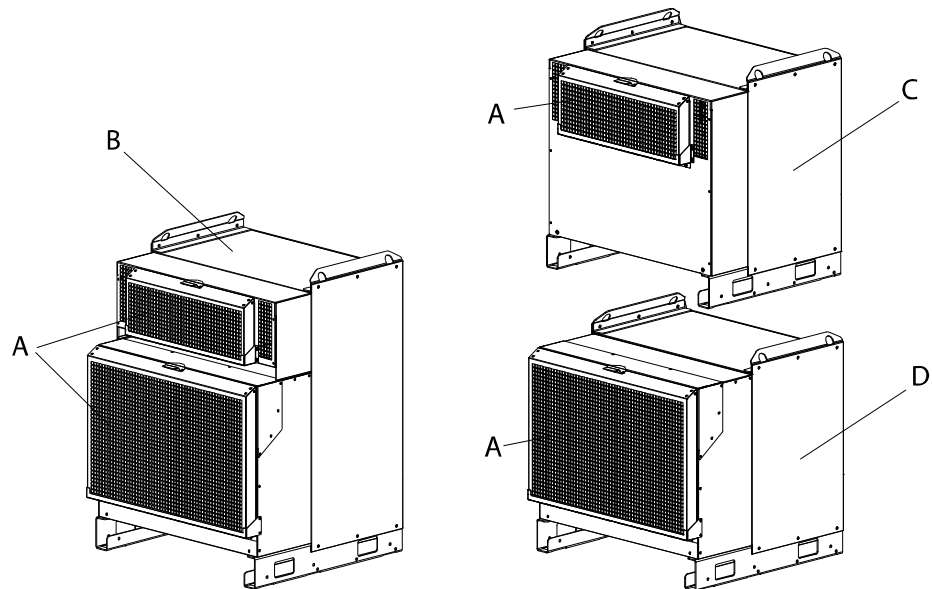

xx0700000128

A	Moist dust filter magazine
B	Single Cabinet Controller
C	Dual Cabinet Controller, Control Module
D	Dual Cabinet Controller, Drive Module

Required equipment

Equipment	Note
Cleaning agent	Water 30-40°C with cleansing liquid or detergent.
Compressed air	

Cleaning

The procedure below details how to clean the moist dust filter.

Action	Note/Illustration
1. Remove the moist dust filter.	How to remove the moist dust filter is detailed in section Replacement of moist dust filter on page 171 .
2. Clean the filter three or four times.	
3. Allow the filter to dry in one of these ways: <ul style="list-style-type: none"> Lying flat on a flat surface Blow with compressed air in opposite direction of filter airflow. 	Do not wring the filter out!
4. Refit the moist dust filter.	How to refit the moist dust filter is detailed in section Replacement of moist dust filter on page 171 .

3 Maintenance activities, controller IRC5

3.4.3. Cleaning the FlexPendant

3.4.3. Cleaning the FlexPendant

Location

The surfaces to clean are shown in the illustration below.

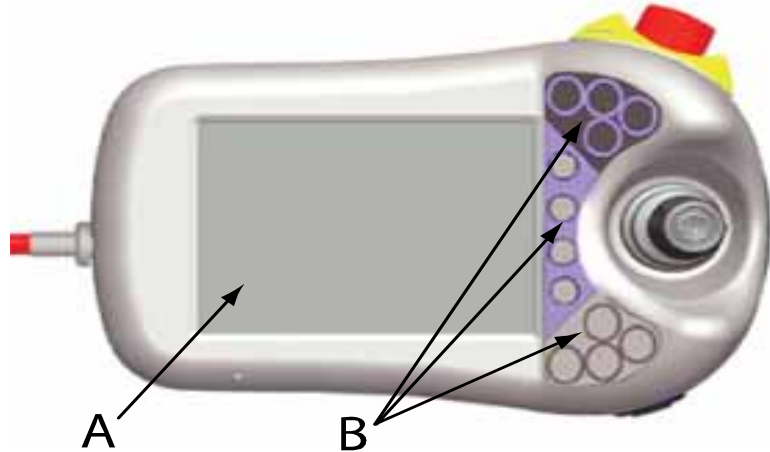

xx0400000973

A	Touch screen
B	Hard buttons

Required equipment

Equipment, etc.	Note
Soft cloth	ESD Protected
Warm water/Mild cleaning agent	

Clean the touch screen



This section details how to clean the touch screen.

Action	Info/Illustration
1. Before cleaning the screen, tap the Lock Screen on the ABB menu.	<p>en0400001221</p>

© Copyright 2004-2010 ABB. All rights reserved.

Continues on next page

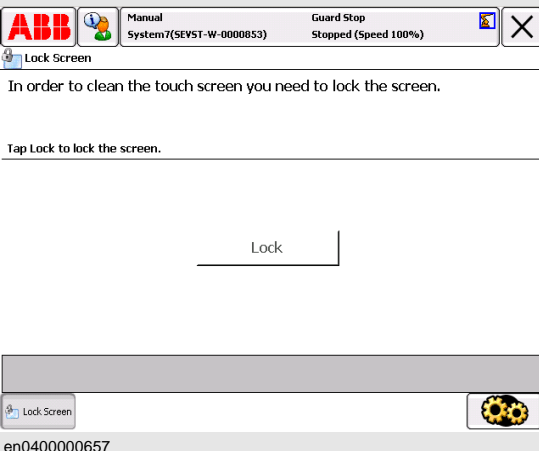
Continued

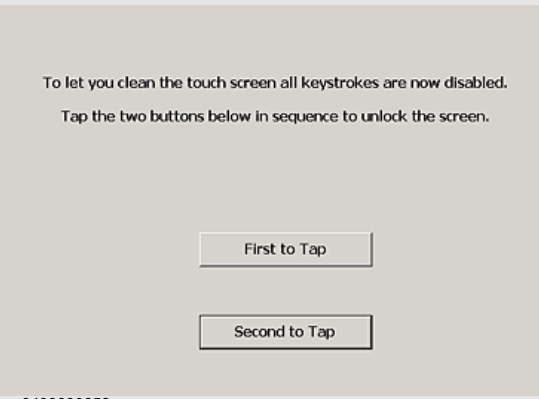
Action	Info/Illustration
<p>2. Tap the Lock button in the following window.</p>	
<p>3. When the next window appears, it is safe to clean the screen.</p>	
<p>4. Clean the touch screen and hardware buttons using a soft cloth and water or a mild cleaning agent.</p>	
<p>5. To unlock the screen, follow the instructions on the screen.</p>	

3 Maintenance activities, controller IRC5

3.4.3. Cleaning the FlexPendant

Continued

Do's and don'ts!

The section below specifies some special considerations when cleaning the FlexPendant.

Always:

- use ESD Protection
- use cleaning equipment as specified above! Any other cleaning equipment may shorten the life time of the touch screen.
- check that all protective covers are fitted to the device before cleaning!
- make sure that no foreign objects or liquids can penetrate into the device.

Never:

- remove any covers before cleaning the FlexPendant!
- spray with a high pressure cleaner!
- clean the device, operating panel and operating elements with compressed air, solvents, scouring agent or scrubbing sponges.

4 Repair activities, controller IRC5

4.1. Overview

General

The ABB IRC5 controller is available in two basic configurations: Single Cabinet Controller and Dual Cabinet Controller.

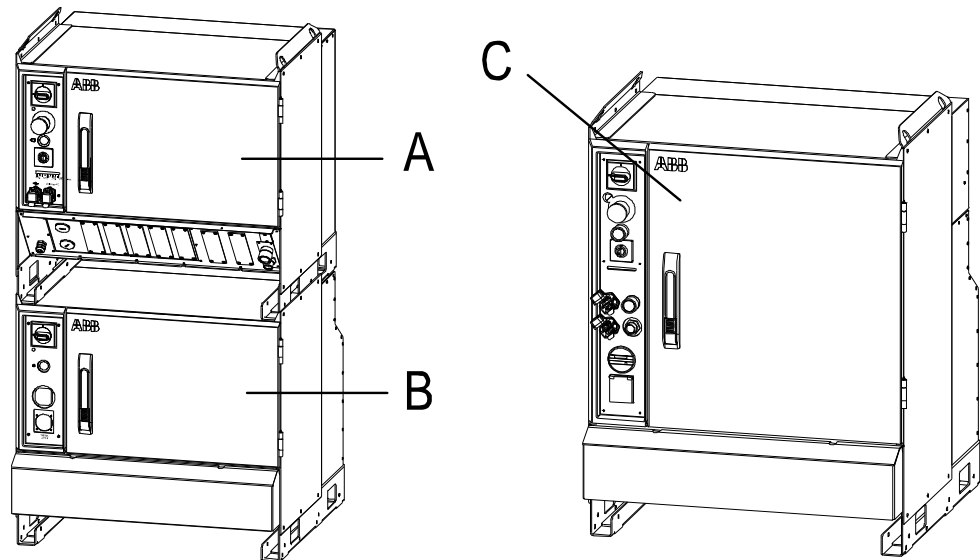

xx0600002929

A	Dual Cabinet (Control Module)
B	Dual Cabinet (Drive Module)
C	Single Cabinet

The Single Cabinet Controller has all components in one single cabinet and the Dual divides the components into two modules: Control Module and Drive Module.

The Single Cabinet Controller is regarded as the standard configuration and therefore the illustration in the procedures detailed in this manual are based on the Single Cabinet Controller.

If the procedure in general is the same, it is mentioned in each procedure where the part is located in the Dual Cabinet configuration. If there are significant differences, both cabinet configurations are shown.



NOTE!

When replacing a unit in the controller, report to ABB:

- the serial number
- article number
- revision

of both the replaced unit and the replacement unit.

This is particularly important for the safety equipment to maintain the safety integrity of the installation.

4 Repair activities, controller IRC5

4.2. Replacement of panel board

4.2. Replacement of panel board

Location

The panel board unit is located as shown in the illustration below.

In the Dual Cabinet Controller the panel board unit is located in the Control Module.

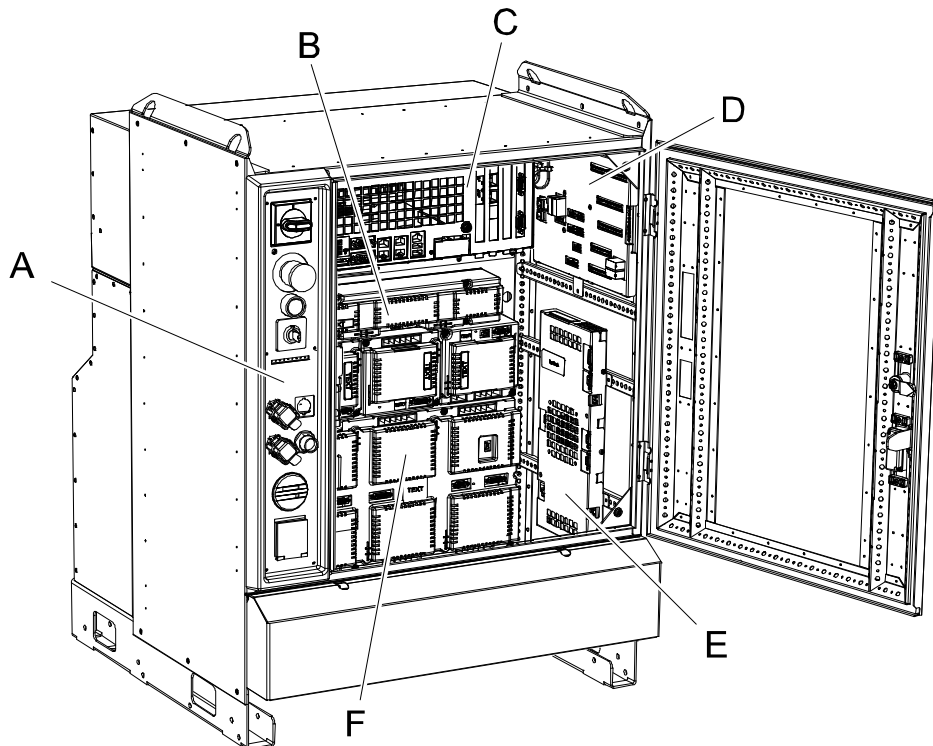

xx0500001858

A	Operator's panel
B	Capacitor
C	Computer unit
D	Panel board unit
E	Axis computer
F	Drive system (drive units and rectifier)

Required equipment



Equipment	Note
Panel board unit	DSQC643 See <i>Controller system parts (Drive System 04) on page 301</i>
Standard toolkit	The contents are defined in section Standard toolkit!
Other tools and procedures may be required. See references to these procedures in the step-by-step instructions below.	These procedures include references to the tools required.
Circuit Diagram	See <i>Circuit Diagram on page 319</i>

© Copyright 2004-2010 ABB. All rights reserved.

Continues on next page

Removal

The procedure below details how to remove the panel board unit.

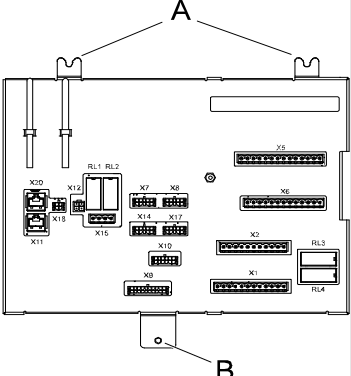
	Action	Note/Illustration
1.	 <p>DANGER! Before commencing any work inside the cabinet, please observe the safety information in section <i>DANGER - Make sure that the main power has been switched off!</i> on page 30.</p>	
2.	 <p>esd WARNING! The unit is sensitive to ESD. Before handling the unit please read the safety information in the section <i>WARNING - The unit is sensitive to ESD!</i> on page 31</p>	
3.	Disconnect all connectors.	<p>Note Make a note of any connections.</p>
4.	Remove the lower attachment screw, and remove the Panel Unit.	 <p>xx0400000812</p> <ul style="list-style-type: none"> • A: fixed attachments • B: hole for attachment screw



4 Repair activities, controller IRC5

4.2. Replacement of panel board

Continued

Refitting

The procedure below details how to refit the panel board unit.

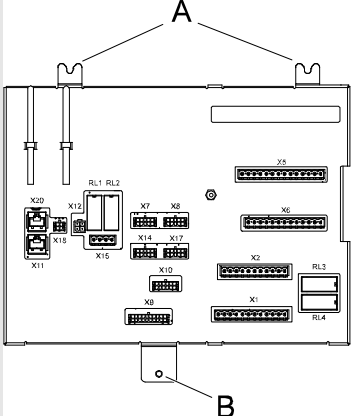
	Action	Note/Illustration
1.	 <p>DANGER! Before commencing any work inside the cabinet, please observe the safety information in section <i>DANGER - Make sure that the main power has been switched off!</i> on page 30.</p>	
2.	 <p>esd WARNING! The unit is sensitive to ESD. Before handling the unit please read the safety information in the section <i>WARNING - The unit is sensitive to ESD!</i> on page 31</p>	
3.	Refit the panel board unit.	
4.	Refit the lower attachment screw.	 <p>xx0400000812</p> <ul style="list-style-type: none"> • A: fixed attachments • B: hole for attachment screw
5.	Reconnect all connectors.	

4.3. Replacement of Flange disconnect

Location

The Flange disconnect unit is located as shown in the illustration below.

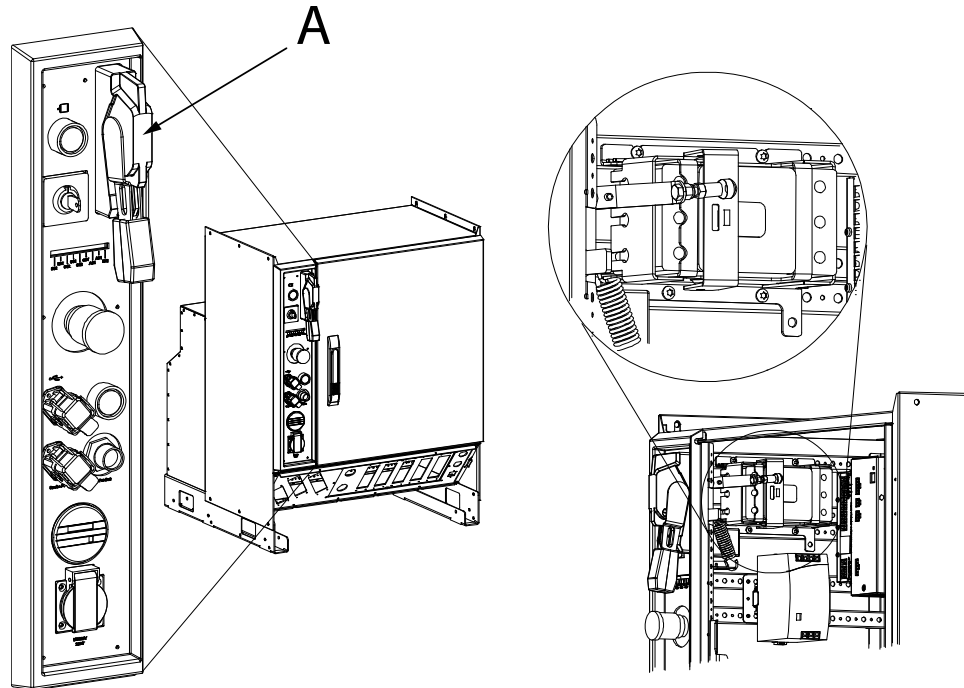

xx0600003133

A Flange disconnect

Required equipment

Equipment	Art. no.	Note
Flange disconnect	3HAC027113-001	
Standard toolkit		The contents are defined in section Standard toolkit!
Other tools and procedures may be required. See references to these procedures in the step-by-step instructions below.		These procedures include references to the tools needed.
Circuit diagram		See Circuit Diagram on page 319 .



4 Repair activities, controller IRC5

4.3. Replacement of Flange disconnect

Continued

Removal

The procedure below details how to remove the Flange disconnect unit.

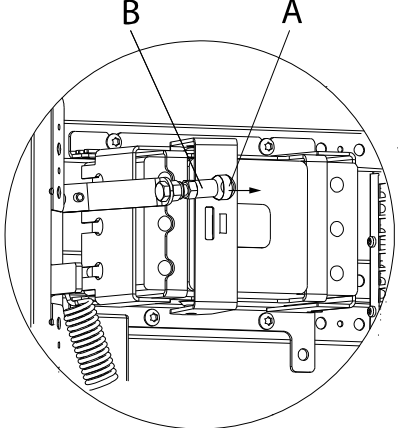
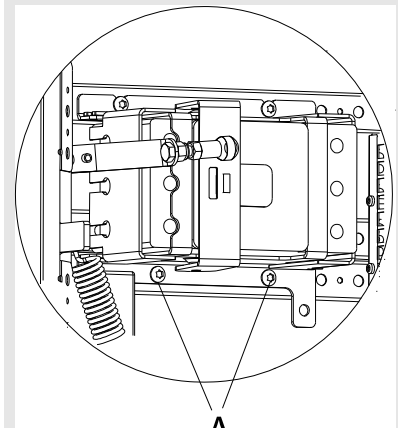
Action	Note/Illustration
1.  DANGER! Before commencing any work inside the cabinet, please observe the safety information in section <i>DANGER - Make sure that the main power has been switched off!</i> on page 30.	
2. Remove the link by pushing the spring forward.  WARNING! Be careful when removing the link. The link is spring-loaded and the spring can with high force pull the link down when it is released.	 <p>xx0600003141</p> <ul style="list-style-type: none">• A: spring• B: link
3. Remove the two lower attachment screws.	 <p>xx0600003139</p> <ul style="list-style-type: none">• A: attachment screws

© Copyright 2004-2010 ABB. All rights reserved.

Continues on next page

Continued

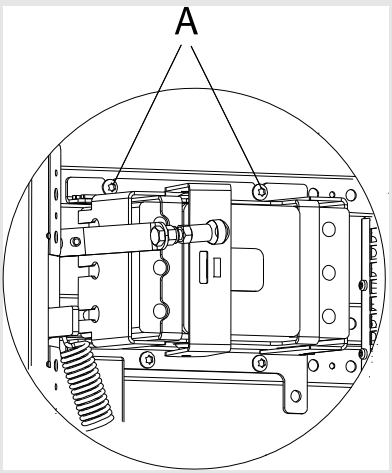
	Action	Note/Illustration
4.	Loosen the two upper attachment screws and remove the unit.	 <p>xx0600003140</p> <ul style="list-style-type: none"> • A: attachment screws
5.	Disconnect the cables.	

Refitting

The procedure below details how to refit the Flange disconnect unit.

	Action	Note/Illustration
1.	 <p>DANGER! Before commencing any work inside the cabinet, please observe the safety information in section DANGER - Make sure that the main power has been switched off! on page 30.</p>	
2.	Reconnect the cables.	
3.	Refit the unit and fasten the two upper attachment screws.	
4.	Refit the two lower attachment screws.	
5.	Refit the link to the unit.	

4 Repair activities, controller IRC5

4.4. Replacement of I/O units and Gateways

4.4. Replacement of I/O units and Gateways

General

A number of I/O units and Gateways may be installed in the IRC5 controller. These are specified in *Definition of I/O units, IRC5 on page 104*.

How to configure the I/O units is detailed in *Operating-manual Robot Studio*.

Location in Single Cabinet Controller

The location of I/O units, Gateways or encoder interface units in the Single Cabinet Controller is shown in the illustration below.

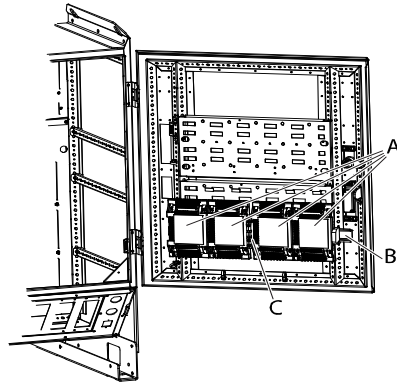

xx0500001859

A	Gateway, I/O Units or encoder interface units
B	Mounting rail

Location in Dual Cabinet Controller

The location of I/O units, Gateways or encoder interface units in the Dual Cabinet Controller is shown in the illustration below.

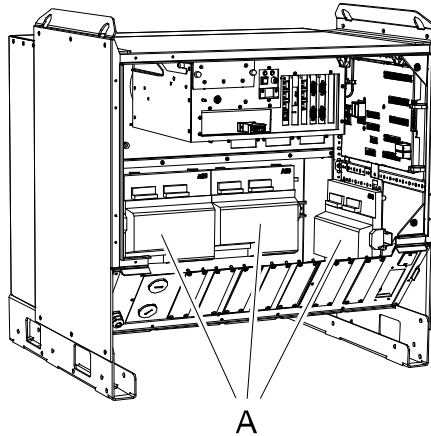

xx0600002684

A	Gateway, I/O Units or encoder interface units
---	---

© Copyright 2004-2010 ABB. All rights reserved.



Continues on next page

Required equipment

Equipment	Note
A number of choices are available!	Specified in section <i>Definition of I/O units, IRC5 on page 104.</i>
Standard toolkit	The contents are defined in section Standard toolkit!
Other tools and procedures may be required. See references to these procedures in the step-by-step instructions below.	These procedures include references to the tools required.
Circuit Diagram	See <i>Circuit Diagram on page 319.</i>

Removal

The procedure below details how to remove the I/O units or Gateways.

	Action	Note/Illustration
1.	 <p>DANGER! Before commencing any work inside the cabinet, please observe the safety information in section <i>DANGER - Make sure that the main power has been switched off! on page 30.</i></p>	
2.	 <p>WARNING! The unit is sensitive to ESD. Before handling the unit please read the safety information in the section <i>WARNING - The unit is sensitive to ESD! on page 31</i></p>	
3.	Identify the I/O unit or Gateway to be replaced.	
4.	Disconnect the connectors from the unit.	Note which connector goes where, to facilitate reassembly.
5.	Tip the unit away from the mounting rail and remove it.	



4 Repair activities, controller IRC5

4.4. Replacement of I/O units and Gateways

Continued

Refitting

The procedure below details how to refit the I/O units or Gateways.

	Action	Note/Illustration
1.	 DANGER! Before commencing any work inside the cabinet, please observe the safety information in section <i>DANGER - Make sure that the main power has been switched off!</i> on page 30.	
2.	 esd WARNING! The unit is sensitive to ESD. Before handling the unit please read the safety information in the section <i>WARNING - The unit is sensitive to ESD!</i> on page 31	
3.	Hook the unit back onto the mounting rail and snap it gently in position.	
4.	Reconnect all connectors disconnected during removal.	

4.5. Replacement of backup energy bank

Location

The illustration below shows the location of the backup energy bank in a Single Cabinet Controller.

In the Dual Cabinet Controller the backup energy bank is located in the Drive Module.

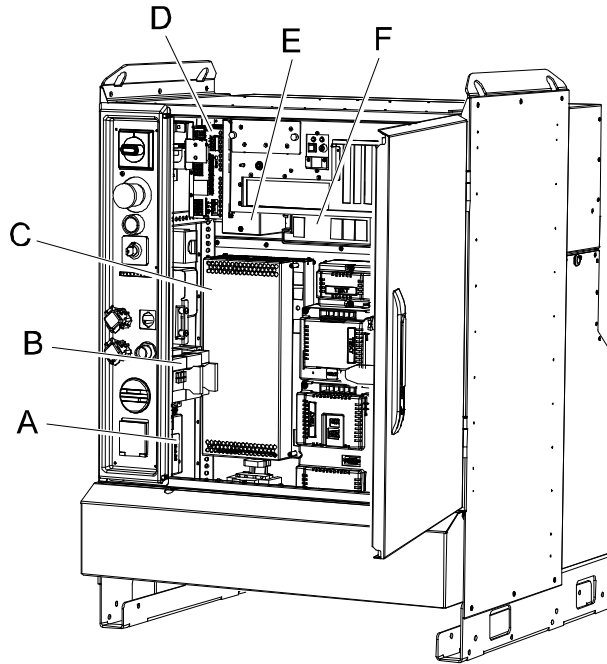

xx0500001951

A	Contactor interface board
B	Contactor
C	Drive system power supply
D	Customer I/O power supply
E	Control power supply
F	Backup energy bank

Required equipment

Equipment	Note
Backup energy bank	DSQC 655 with or without adapter plate. See Controller system parts (Drive System 04) on page 301.
Standard toolkit	The contents are defined in section Standard toolkit!
Other tools and procedures may be required. See references to these procedures in the step-by-step instructions below.	These procedures include references to the tools required.
Circuit Diagram	See Circuit Diagram on page 319.

Continues on next page

4 Repair activities, controller IRC5

4.5. Replacement of backup energy bank

Continued

Removal

The procedure below details how to remove the backup energy bank.

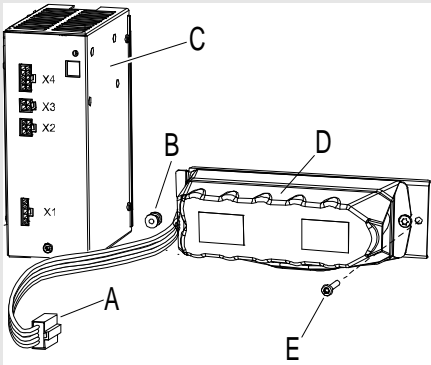
	Action	Note/Illustration
1.	 DANGER! Before commencing any work inside the cabinet, please observe the safety information in section <i>DANGER - Make sure that the main power has been switched off!</i> on page 30.	
2.	Disconnect the connector X4 from the control power supply.	 <p>xx0600002900</p> <ul style="list-style-type: none">• A: connector• B: cup nut• C: control power supply• D: backup energy bank• E: attachment screw
3.	Remove the <i>attachment screw</i> .	
4.	Pull the <i>backup energy bank</i> out.	

© Copyright 2004-2010 ABB. All rights reserved.

Refitting

The procedure below details how to refit the backup energy bank.

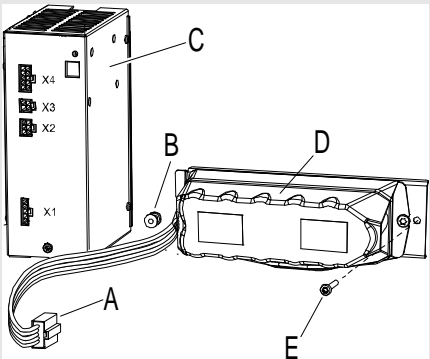
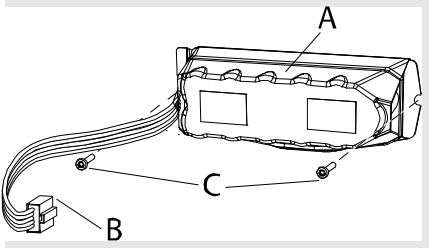
	Action	Note/Illustration
1.	 <p>DANGER! Before commencing any work inside the cabinet, please observe the safety information in section <i>DANGER - Make sure that the main power has been switched off!</i> on page 30.</p>	
2.	Refit the new backup energy bank.	 <p>xx0600002900</p> <ul style="list-style-type: none"> • A: connector • B: cup nut • C: control power supply • D: backup energy bank • E: attachment screw
3.	Refit the <i>attachment screw</i> , and tighten it.	 <p>xx0600003231</p> <ul style="list-style-type: none"> • A: Backup energy bank • B: connector • C: attachment screws
4.	Reconnect the connector to the <i>control power supply</i> connector X4.	
5.	Refit the front with the Panel Board Unit.	

4 Repair activities, controller IRC5

4.6. Replacement of control system fan

4.6. Replacement of control system fan

Location

The control system fan is located in the back of the Single Cabinet Controller as shown below. On the Dual Cabinet Controller the control system fan is located on the Control Module.

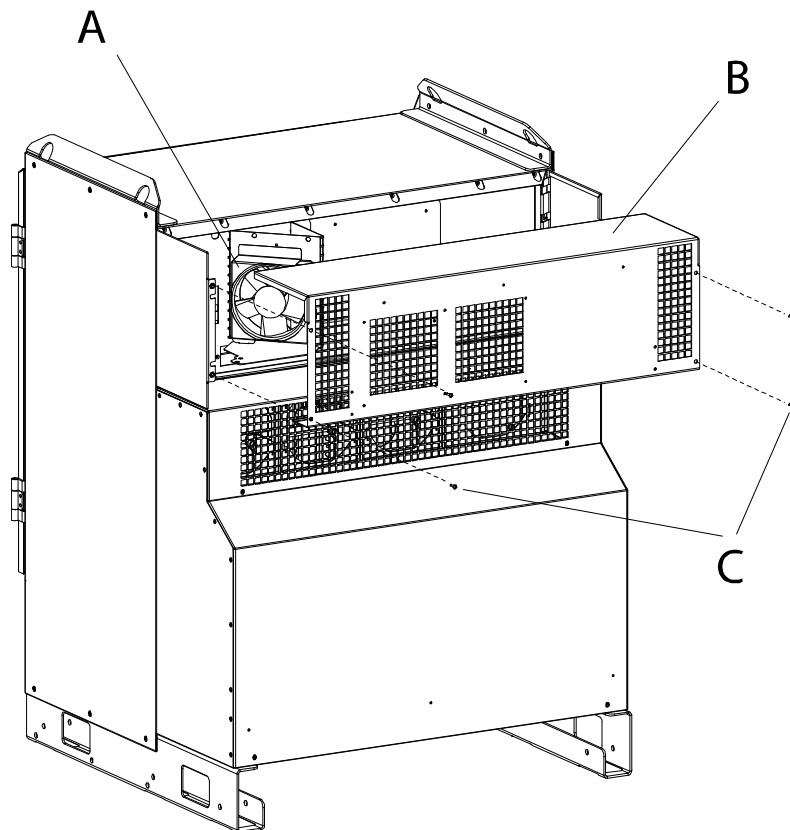

xx070000416

A	Fan
B	Top cover
C	Attachment screws (4 pcs)

Required equipment

Equipment	Note
Fan with receptacle	See Miscellaneous parts on page 306 .
Standard toolkit	The contents are defined in section Standard toolkit, IRC5 on page 299
Other tools and procedures may be required. See references to these procedures in the step-by-step instructions below.	
Circuit diagram	See Circuit Diagram on page 319 .

© Copyright 2004-2010 ABB. All rights reserved.

Continues on next page

Removal of control system fan

The procedure below details how to remove the control system fan.

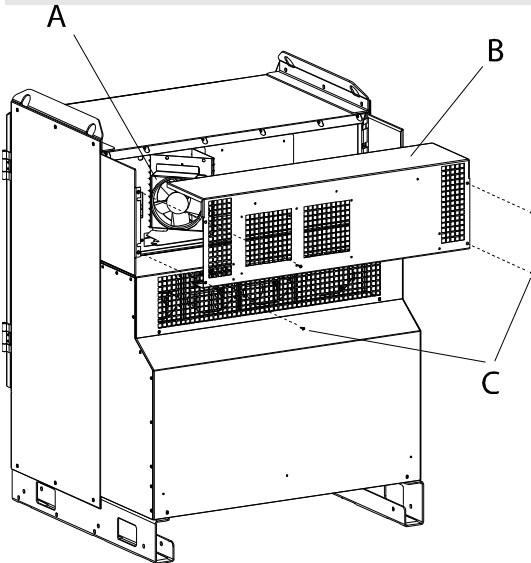
	Action	Note/Illustration
1.	 <p>DANGER! Before commencing any work inside the cabinet, please observe the safety information in section <i>DANGER - Make sure that the main power has been switched off!</i> on page 30.</p>	
2.	Remove the attachment screws on the top cover.	 <p>xx0700000416</p> <ul style="list-style-type: none"> • A: fan • B: top cover • C: attachment screws (4 pcs)
3.	Remove the top cover.	
4.	Disconnect the connector to the fan.	
5.	Remove the screw (item B in image below).	

4 Repair activities, controller IRC5

4.6. Replacement of control system fan

Continued

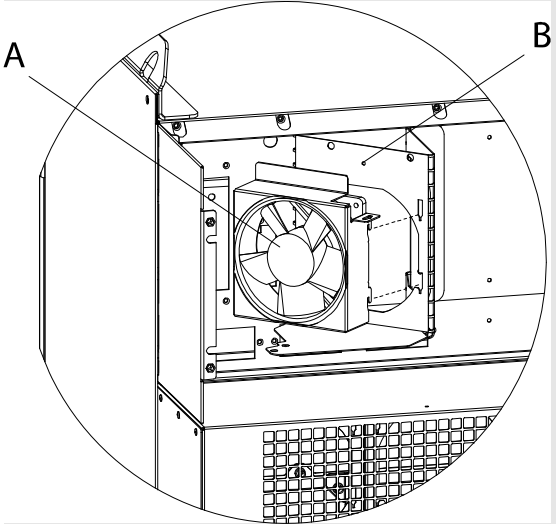
	Action	Note/Illustration
	6. Push the fan upwards, and pull it out.	 <p>xx0700000417</p> <ul style="list-style-type: none">• A: fan• B: screw

Refitting of control system fan

The procedure below details how to refit the control system fan.

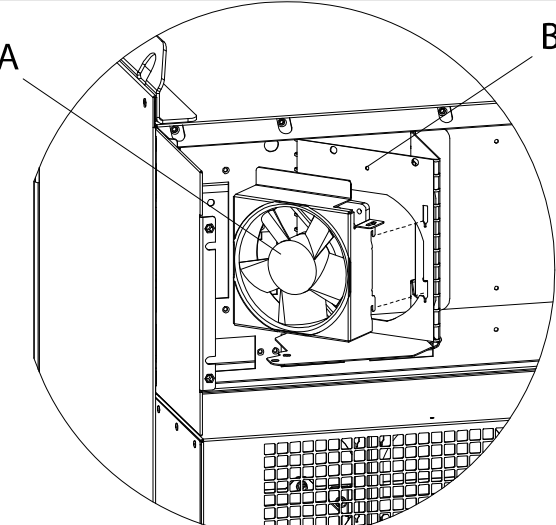
	Action	Note/Illustration
	1. Put the fan in place, and push it down.	 <p>xx0700000417</p> <ul style="list-style-type: none">• A: fan• B: screw
	2. Refit the screw (item B in image above).	
	3. Reconnect the connector to the fan.	

© Copyright 2004-2010 ABB. All rights reserved.

Continues on next page

Continued

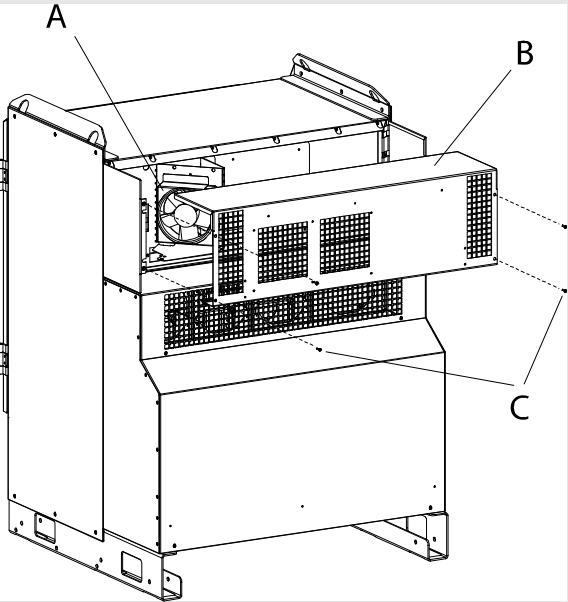
	Action	Note/Illustration
4.	Refit the top cover.	 <p>xx0700000416</p> <ul style="list-style-type: none"> • A: fan • B: top cover • C: attachment screws (4 pcs)
5.	Refit the attachment screws.	

4 Repair activities, controller IRC5

4.7. Replacement of heat exchange unit and fan

4.7. Replacement of heat exchange unit and fan

Location

The heat exchanger unit is located in the back of the Control Module as shown below. On the Dual Cabinet Controller the heat exchange unit is located on the Control Module.

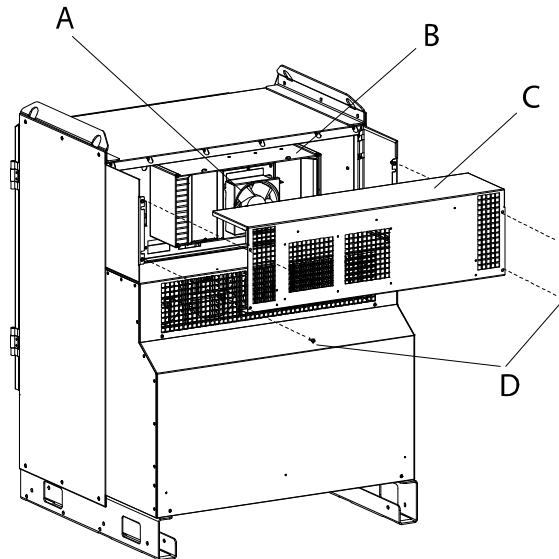

xx0500001952

A	Fan
B	Heat exchanger
C	Top cover
D	Attachment screws (4 pcs)

Required equipment

Equipment	Spare part no.	Note
Fan with receptacle	3HAC021700-001	Room temp MAX52°C IRB 6600, IRB 7600 IRB 660 and IRB 6620
Fan with receptacle	3HAC021702-001	Room temp (MAX45°C) or Room temp (MAX52°C) IRB 140, IRB 340 IRB 1400, IRB 2400, IRB 4400 and IRB 1600
Heat exchange unit	3HAC024439-001	Room temp MAX52°C
Adhesive		Product name, Casco S55
Standard toolkit		The contents are defined in section Standard toolkit, IRC5 on page 299 .
Other tools and procedures may be required. See references to these procedures in the step-by-step instructions below.		These procedures include references to the tools required.
Circuit Diagram		See Circuit Diagram on page 319 .

© Copyright 2004-2010 ABB. All rights reserved.

Continues on next page

Removal of heat exchanger fan

The procedure below details how to remove the heat exchange unit fan.

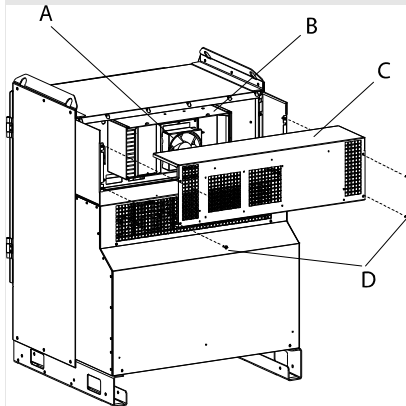
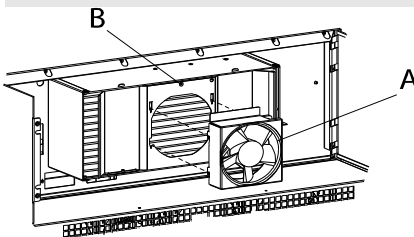
	Action	Note/Illustration
1.	 <p>DANGER! Before commencing any work inside the cabinet, please observe the safety information in section <i>DANGER - Make sure that the main power has been switched off!</i> on page 30.</p>	
2.	Remove the attachment screw on the top cover.	 <p style="font-size: small;">xx0500001952</p> <ul style="list-style-type: none"> • A: fan • A: heat exchanger • C: top cover • B: attachment screws (4 pcs)
3.	Remove the <i>top cover</i> .	Shown in the figure above.
4.	Disconnect the connector to the fan.	
5.	Remove the screw (item B in image below).	
6.	Push the fan upwards, and pull it out.	 <p style="font-size: small;">xx0500001954</p> <ul style="list-style-type: none"> • A: fan • B: screw

4 Repair activities, controller IRC5

4.7. Replacement of heat exchange unit and fan

Continued

Refitting of heat exchanger fan

The procedure below details how to refit the heat exchange unit fan.

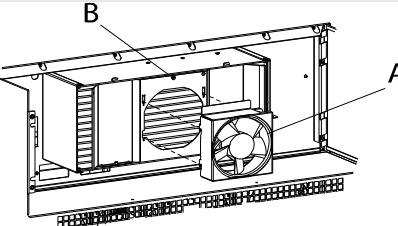
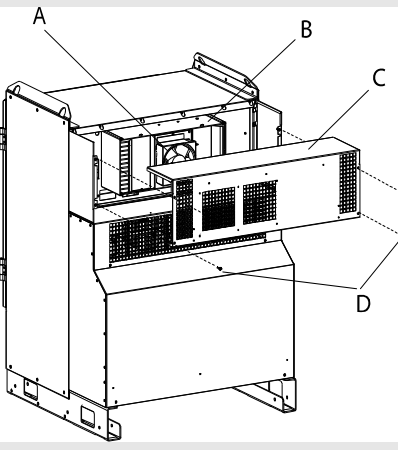
Action	Note/Illustration
1. Put the new fan in place, and push down.	 <p>xx0500001954</p> <ul style="list-style-type: none">• A: fan• B: screw
2. Refit the screw (item B in image above).	
3. Reconnect the connector to fan.	
4. Refit the top cover.	 <p>xx0500001952</p> <ul style="list-style-type: none">• A: fan• B: heat exchanger• C: top cover• B: attachment screws (4 pcs)
5. Refit the <i>attachment screws</i>	Shown in the figure above.

© Copyright 2004-2010 ABB. All rights reserved.

Replacement of heat exchange unit

The procedure below details how to remove the heat exchange unit.

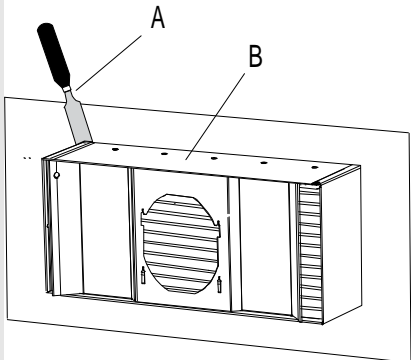
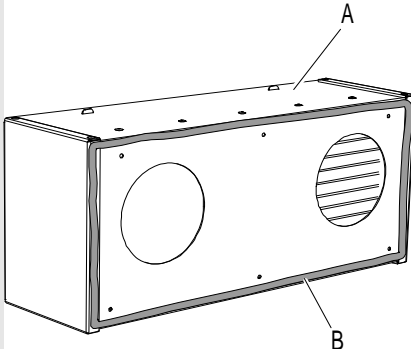
	Action	Note/Illustration
1.	 <p>DANGER! Before commencing any work inside the cabinet, please observe the safety information in section <i>DANGER - Make sure that the main power has been switched off!</i> on page 30.</p>	
2.	Follow step 2 through 5 in <i>Removal of heat exchanger fan on page 197.</i>	
3.	Mark the placement of the heat exchange unit with a pen before removal.	
4.	Use a chisel and a hammer to wedge between the heat exchange unit and cabinet wall in all four corners of the heat exchanger.	 <p>xx0600002677</p> <ul style="list-style-type: none"> • A: chisel • B: heat exchange unit
5.	Remove the exchanger unit.	
6.	Apply the adhesive on a cleaned and dry surface on the new heat exchanger unit.	 <p>xx0600002678</p> <ul style="list-style-type: none"> • A: heat exchange unit • B: adhesive run
7.	Fit the new heat exchange unit within 20min. It could be necessary to fixate the unit in position until the adhesive is hard.	
8.	Follow the step 1 to 4 in <i>Refitting of heat exchanger fan on page 198.</i>	

4 Repair activities, controller IRC5

4.8. Replacement of computer unit DSQC639

4.8. Replacement of computer unit DSQC639

Location

The computer unit is located in the top of the module as shown below. In the Dual Cabinet Controller the computer unit is located in the Control Module.

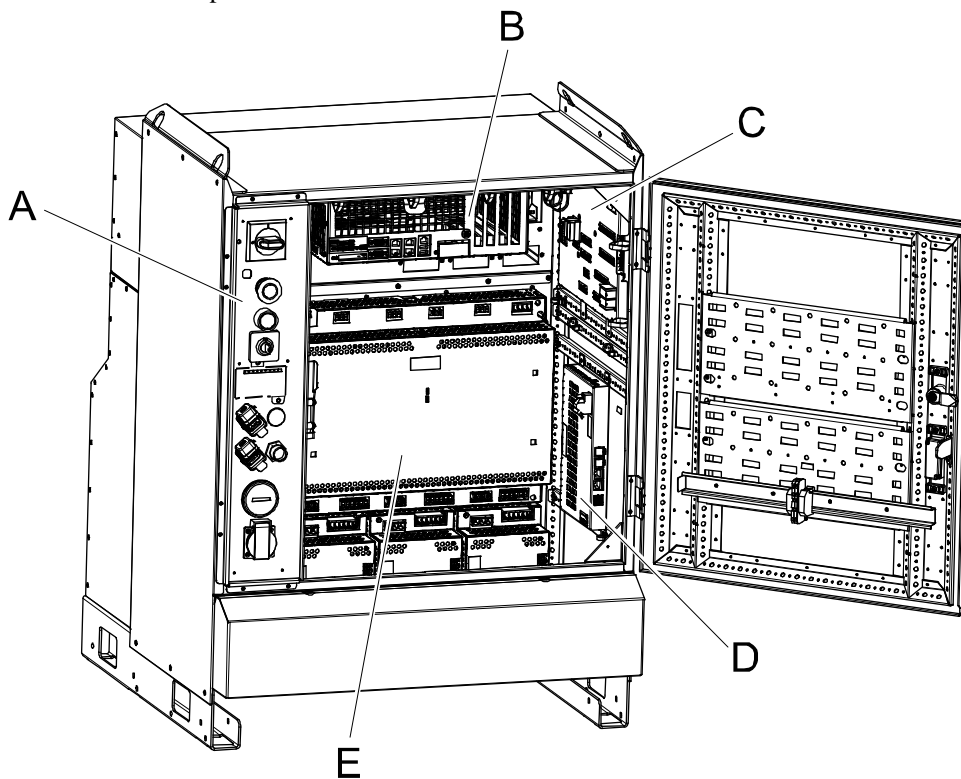

en080000476

	Description
A	Operator's panel
B	Computer unit
C	Panel unit
D	Axis computer
E	Drive system (drive units and rectifier)

Required equipment

Equipment	Note
Computer unit	DSQC 639 See Computer unit DSQC 639 parts on page 305 .
Standard toolkit	The contents are defined in section Standard toolkit.
Other tools and procedures may be required. See references to these procedures in the step-by-step instructions below.	These procedures include references to the tools required.
Circuit diagram	See Circuit Diagram on page 319

© Copyright 2004-2010 ABB. All rights reserved.

Continues on next page





Removal

The procedure below details how to remove the computer unit.

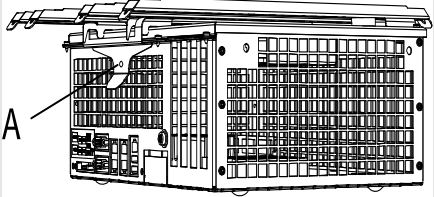

NOTE!

The computer unit can have different design. The procedure how to remove the computer unit is the same.

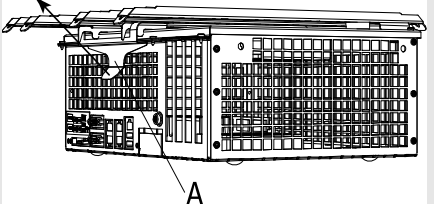
	Action	Note/Illustration
1.	 <p>DANGER! Before commencing any work inside the cabinet, please observe the safety information in section <i>DANGER - Make sure that the main power has been switched off!</i> on page 30.</p>	
2.	 <p>WARNING! The unit is sensitive to ESD. Before handling the unit please read the safety information in the section <i>WARNING - The unit is sensitive to ESD!</i> on page 31</p>	
3.	Disconnect all connectors from the computer unit.	NOTE! Make a note of any connections.
4.	Remove the transportation screw.	 <p>xx0600003048</p> <ul style="list-style-type: none"> A: transportation screw
5.	<p>Support the computer unit beneath by hand and push the spring lock in the arrow direction.</p>  <p>WARNING! Prevent the computer unit from falling down due to gravity when releasing the spring lock by supporting the computer unit from beneath by hand.</p>	 <p>xx0600002965</p> <ul style="list-style-type: none"> A: Spring lock

4 Repair activities, controller IRC5

4.8. Replacement of computer unit DSQC639

Continued

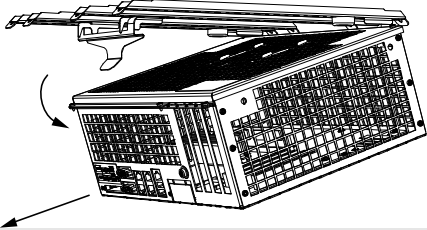
	Action	Note/Illustration
6.	Let the front end of the computer unit down and pull the unit out.	 <p>xx0600002966</p>



Refitting

The procedure below details how to refit the computer unit.



NOTE!

The computer unit can have different design. The procedure how to refit the computer unit is the same.

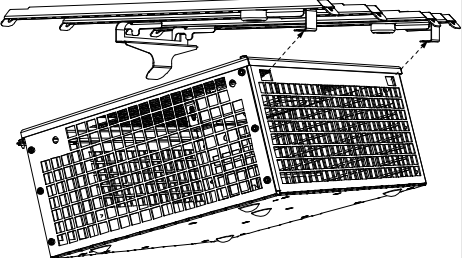
	Action	Note/Illustration
1.	 <p>DANGER! Before commencing any work inside the cabinet, please observe the safety information in section <i>DANGER - Make sure that the main power has been switched off!</i> on page 30.</p>	
2.	 <p>esd WARNING! The unit is sensitive to ESD. Before handling the unit please read the safety information in the section <i>WARNING - The unit is sensitive to ESD!</i> on page 31</p>	
3.	Fit the computer unit in position	 <p>xx0600002967</p>

© Copyright 2004-2010 ABB. All rights reserved.

Continues on next page

Continued

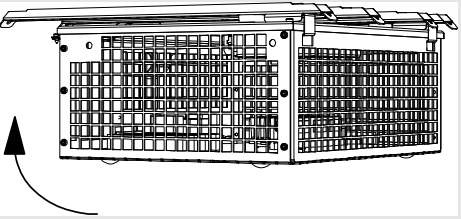
	Action	Note/Illustration
4.	Push the computer unit up until the spring lock snaps into position.	 <p data-bbox="970 577 1077 600">xx0600002968</p>
5.	Refit the transportation screw.	
6.	Reconnect all connectors to the computer unit.	
7.	Refit the front with the Panel Board Unit.	

4 Repair activities, controller IRC5

4.9. Replacement of motherboard in computer unit DSQC639

4.9. Replacement of motherboard in computer unit DSQC639

Location

The motherboard is located as shown in the figure below.

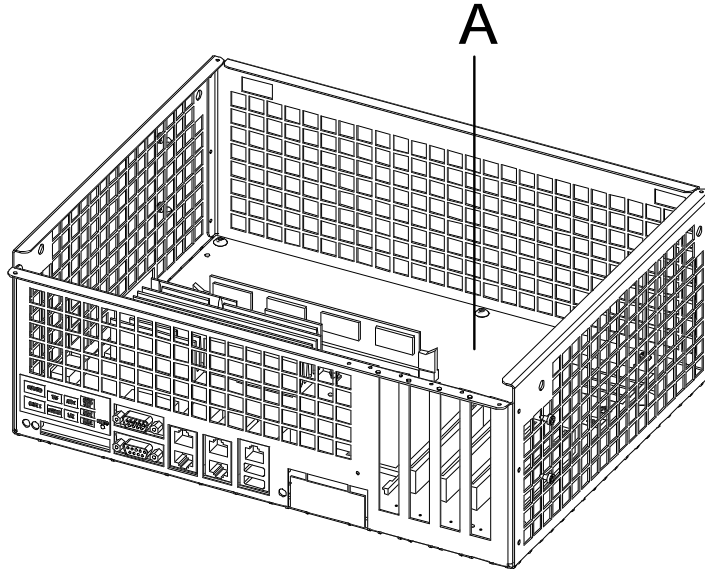

xx0600002912

A	Motherboard
---	-------------

Required equipment

Equipment	Note
Computer unit	DSQC 639 See Computer unit DSQC 639 parts on page 305 .
Standard toolkit	The contents are defined in section Standard toolkit.
Other tools and procedures may be required. See references to these procedures in the step-by-step instructions below.	These procedures include references to the tools required.
Circuit diagram	See Circuit Diagram on page 319

Removal



The procedure below details how to remove the motherboard in the computer unit.

Action	Note/Illustration
1.  DANGER! Before commencing any work inside the cabinet, please observe the safety information in section DANGER - Make sure that the main power has been switched off! on page 30 .	

© Copyright 2004-2010 ABB. All rights reserved.

Continues on next page

Continued

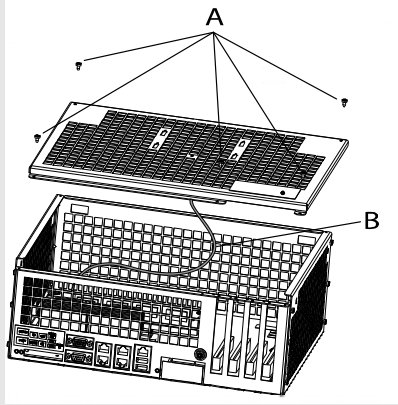
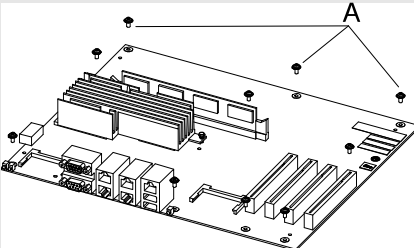
	Action	Note/Illustration
2.	 <p>WARNING! The unit is sensitive to ESD. Before handling the unit please read the safety information in the section <i>WARNING - The unit is sensitive to ESD! on page 31</i></p>	
3.	Remove the computer unit.	Detailed in section Replacement of computer unit DSQC639 on page 200
4.	Remove the five attachment screws, and remove the cover plate.  <p>WARNING! Be careful with the fan cable when opening and removing the cover plate. The fan cable must not be stretched.</p>	 <p>xx0600002913</p> <ul style="list-style-type: none"> • A: attachment screw (5 pcs) • B: fan cable
5.	Disconnect the fan cable from the motherboard.	
6.	Remove the Compact flash disk.	Detailed in section Replacement of Compact Flash memory in computer unit DSQC639 on page 223 .
7.	Remove the PCI boards.	Detailed in section Replacement of PCI boards in the computer unit DSQC639 on page 211 .
8.	Remove the ten motherboard attachment screws	 <p>xx0600002914</p> <ul style="list-style-type: none"> • A: attachment screw (10 pcs) <p>Always grip the board around the edges to avoid damage to the board or its components!</p>
9.	Gently lift the motherboard out.	Immediately put the board in an ESD safe bag or similar.

Continues on next page



4 Repair activities, controller IRC5

4.9. Replacement of motherboard in computer unit DSQC639

Continued

Refitting

The procedure below details how to refit the motherboard in the computer unit.

	Action	Note/Illustration
1.	 DANGER! Before commencing any work inside the cabinet, please observe the safety information in section <i>DANGER - Make sure that the main power has been switched off!</i> on page 30.	
2.	 esd WARNING! The unit is sensitive to ESD. Before handling the unit please read the safety information in the section <i>WARNING - The unit is sensitive to ESD!</i> on page 31	
3.	Gently lift the motherboard out of the ESD safe bag and fit it into position in the computer unit.	Always grip the board around the edges to avoid damage to the board or its components!
4.	Secure the motherboard with its attachment screws.	
5.	Refit the PCI boards.	Detailed in section <i>Replacement of PCI boards in the computer unit DSQC639</i> on page 211.
6.	Refit the flash disk.	Detailed in section <i>Replacement of Compact Flash memory in computer unit DSQC639</i> on page 223.
7.	Reconnect the fan connector on the motherboard and refit the cover plate.	
8.	Refit the computer unit.	Detailed in section <i>Replacement of computer unit DSQC639</i> on page 200

4.10. Replacement of DDR SDRAM memory on motherboard in computer unit DSQC639

Location

The following illustration shows the location of the DDR SDRAM memory.

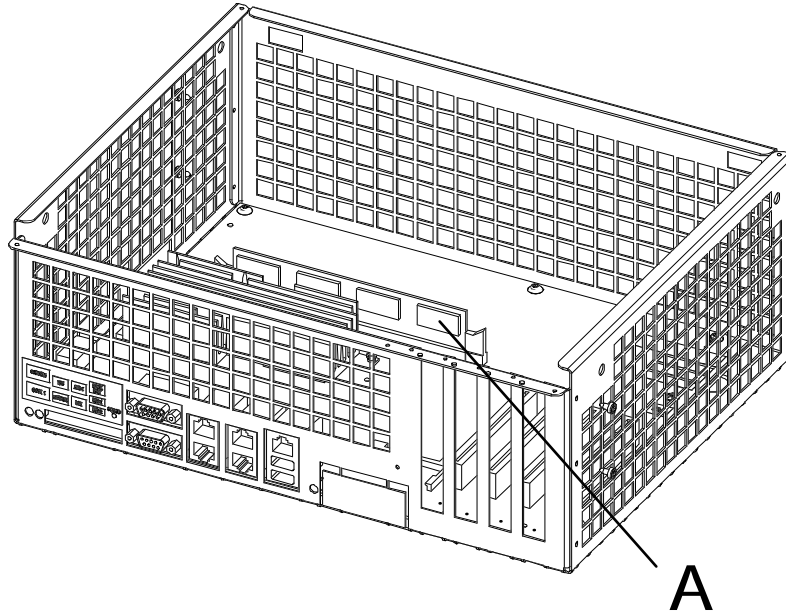

xx0600003031

A DDR SDRAM memory

Required equipment

Equipment	Note
Computer unit DSQC639	DSQC 639 See Computer unit DSQC 639 parts on page 305 .
DDR SDRAM 256MB	See Computer unit DSQC 639 parts on page 305 .
Standard toolkit	The contents are defined in section Standard toolkit, IRC5 on page 299 .
Other tools and procedures may be required. See references to these procedures in the step-by-step instructions below.	These procedures include references to the tools required.
Circuit diagram	See Circuit Diagram on page 319



4 Repair activities, controller IRC5

4.10. Replacement of DDR SDRAM memory on motherboard in computer unit DSQC639

Continued

Removal

Use this procedure to remove the DDR SDRAM memory on the motherboard in the computer unit.

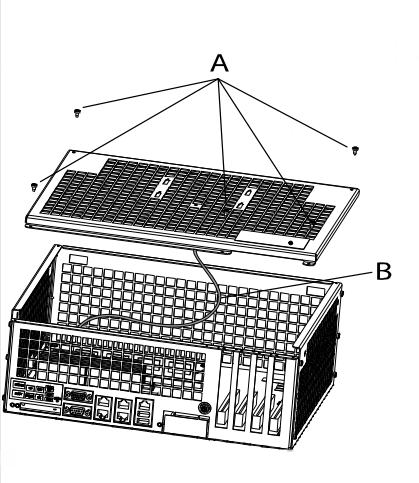
	Action	Note/Illustration
1.	 <p>DANGER! Before commencing any work inside the cabinet, please observe the safety information in section <i>DANGER - Make sure that the main power has been switched off!</i> on page 30.</p>	
2.	 <p>esd WARNING! The unit is sensitive to ESD. Before handling the unit please read the safety information in the section <i>WARNING - The unit is sensitive to ESD!</i> on page 31</p>	
3.	Remove the computer unit	Detailed in section <i>Replacement of computer unit DSQC639</i> on page 200.
4.	<p>Remove the five attachment screws, and remove the cover plate.</p>  <p>WARNING! Be careful with the fan cable when opening and removing the cover plate. The fan cable must not be stretched.</p>	 <p>xx0600002913</p> <ul style="list-style-type: none"> • A: attachment screws (5 pcs) • B: fan cable
5.	Disconnect the fan cable from the motherboard.	

© Copyright 2004-2010 ABB. All rights reserved.

Continues on next page

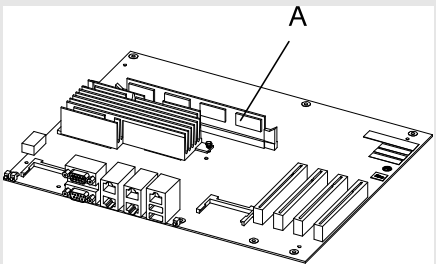

4.10. Replacement of DDR SDRAM memory on motherboard in computer unit DSQC639

Continued

Action	Note/Illustration
<p>6. Gently lift the DDR SDRAM memory straight up.</p>	 <p>xx0600003033</p> <ul style="list-style-type: none"> • A: DDR SDRAM memory <p>NOTE! Always grip the memory around the edges to avoid damage to the memory or its components!</p> <p>NOTE! Immediately put the memory in an ESD safe bag or similar!</p>

Refitting

Use this procedure to refit the DDR SDRAM memory on the motherboard in the computer unit.

Action	Note/illustration
<p>1.  DANGER! Before commencing any work inside the cabinet, please observe the safety information in section <i>DANGER - Make sure that the main power has been switched off!</i> on page 30.</p>	
<p>2.  esd WARNING! The unit is sensitive to ESD. Before handling the unit please read the safety information in the section <i>WARNING - The unit is sensitive to ESD!</i> on page 31</p>	

4 Repair activities, controller IRC5

4.10. Replacement of DDR SDRAM memory on motherboard in computer unit DSQC639

Continued

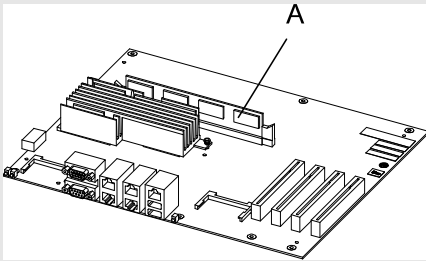
	Action	Note/illustration
3.	Gently lift the DDR SDRAM memory out of the ESD safe bag and fit it into position on the motherboard.	 <p>xx0600003033</p> <ul style="list-style-type: none">• A: DDR SDRAM memory <p>NOTE! Always grip the memory around the edges to avoid damage to the memory or its components!</p>
4.	Reconnect the fan connector on the motherboard and refit the cover plate.	
5.	Refit the computer unit.	Section Replacement of computer unit DSQC639 on page 200 .

4.11. Replacement of PCI boards in the computer unit DSQC639

Location

A number of boards may be fitted in the slots in the computer unit as shown in the figure below:

- Ethernet card
- Interbus Master/Slave with copper interface
- Interbus Master/Slave with fiber-optic interface
- Profibus-DP Master/Slave
- DeviceNet Master/Slave single
- DeviceNet Master/Slave dual
- PROFINET Master/Slave

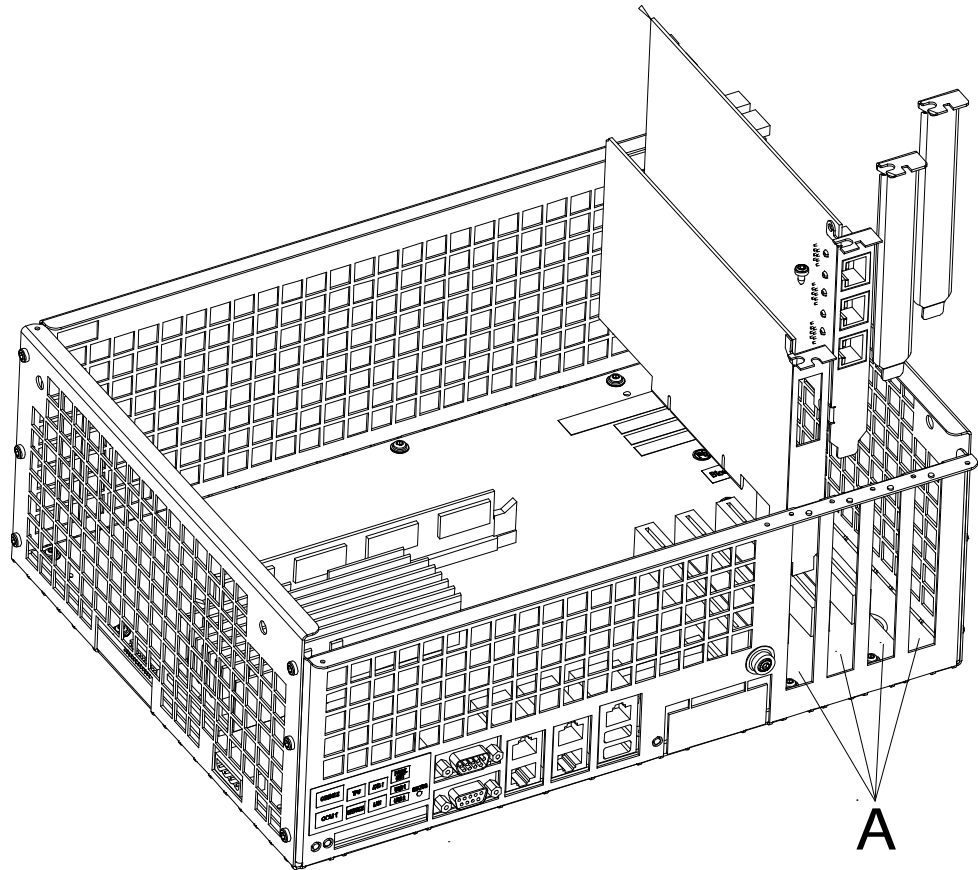

xx0600002915

	Description
A	Slots for PCI cards

4 Repair activities, controller IRC5

4.11. Replacement of PCI boards in the computer unit DSQC639

Continued

Required equipment



Equipment	Art. no.	Note
Ethernet card	3HAC15639-1	DSQC 612. Used with MultiMove and EtherNet/IP Master/Slave. See <i>Application manual - MultiMove</i> or <i>Application manual - EtherNet/IP Master/Slave</i>
Interbus Master/Slave copper wire	3HAC11819-1	DSQC 529. Interbus communication is described in <i>Application manual - InterBus</i> .
Interbus Master/Slave optical fibre	3HAC5579-1	DSQC 512. Interbus communication is described in <i>Application manual - InterBus</i> .
Profibus-DP Master/Slave	3HAC023047-001	DSQC 637. Profibus communication is described in <i>Application manual - PROFIBUS-DP</i> .
Profibus-DP Master/Slave	3HAC031166-001	DSQC 687. Profibus communication is described in <i>Application manual - PROFIBUS-DP</i> .
DeviceNet Master/Slave single	3HAC025779-001	DSQC 658. DeviceNet communication is described in <i>Application manual - DeviceNet</i> .
DeviceNet Master/Slave dual	3HAC025780-001	DSQC 659. DeviceNet communication is described in <i>Application manual - DeviceNet</i> .
PROFINET Master/Slave	3HAC030327-001	DSQC 678 PROFINET communication is described in <i>Application manual -PROFINET master/slave</i> .
Standard toolkit		The contents are described in section Standard toolkit, IRC5 on page 299 .
Other tools and procedures may be required. See references to these procedures in the step-by-step instructions below.		These procedures include references to tools required.
Application manual - PROFIBUS-DP	3HAC023008-001	Contains information on how to configure the system for Profibus cards.
Application manual - InterBus	3HAC023009-001	Contains information on how to configure the system for Interbus cards.
Application manual - DeviceNet	3HAC020676-001	Contains information on how to configure the system for DeviceNet cards.
Application manual -PROFINET master/slave	3HAC031975-001	Contains information on how to configure the system for PROFINET master/slave card DSQC 678.
Circuit diagram		See Circuit Diagram on page 319 .

© Copyright 2004-2010 ABB. All rights reserved.

Continues on next page

Removal

The procedure below details how to remove the PCI cards from the computer unit.

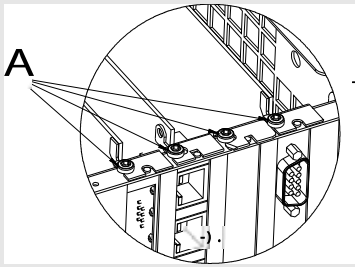
	Action	Note/Illustration
1.	 <p>DANGER! Before commencing any work inside the cabinet, please observe the safety information in section <i>DANGER - Make sure that the main power has been switched off!</i> on page 30.</p>	
2.	 <p>esd WARNING! The unit is sensitive to ESD. Before handling the unit please read the safety information in the section <i>WARNING - The unit is sensitive to ESD!</i> on page 31</p>	
3.	Remove the computer unit.	Detailed in section <i>Replacement of computer unit DSQC639</i> on page 200.
4.	Open the computer unit.	Detailed in section <i>Replacement of motherboard in computer unit DSQC639</i> on page 204.
5.	Identify the card to be replaced.	The barcode sticker contains information on type designation.
6.	Disconnect any cables to/from the PCI board	Make a note of which cables are disconnected.
7.	Remove the attachment screw on top of the card bracket.	 <p>xx0600002916</p> <ul style="list-style-type: none"> A: attachment screws <p>NOTE! Always grip the card around the edges to avoid damage to the card or its components!</p>
8.	Gently lift the card straight up.	NOTE! Immediately put the card in an ESD safe bag or similar!



4 Repair activities, controller IRC5

4.11. Replacement of PCI boards in the computer unit DSQC639

Continued

Refitting

The procedure below details how to refit the PCI cards in the computer unit.

	Action	Note/Illustration
1.	 DANGER! Before commencing any work inside the cabinet, please observe the safety information in section DANGER - Make sure that the main power has been switched off! on page 30.	
2.	 esd WARNING! The unit is sensitive to ESD. Before handling the unit please read the safety information in the section WARNING - The unit is sensitive to ESD! on page 31	
3.	Fit the card in position by pushing the card into the socket on the motherboard. Secure it with its attachment screw on top of the card bracket.	NOTE! Always grip the card around the edges to avoid damage to the card or its components!
4.	Reconnect any additional cables to the PCI board.	
5.	Close the computer unit.	Detailed in section Replacement of motherboard in computer unit DSQC639 on page 204.
6.	Refit the computer unit.	Detailed in section Replacement of computer unit DSQC639 on page 200.
7.	Make sure the robot system is configured to reflect the PCI cards installed.	Detailed in section Required equipment on page 212.

4.12. Replacement of fieldbus adapter in the computer unit DSQC639

Location

The following fieldbus adapter may be fitted in the slot as shown in the figure below:

- EtherNet/IP Fieldbus Adapter
- PROFIBUS Fieldbus Adapter
- PROFINET Fieldbus Adapter

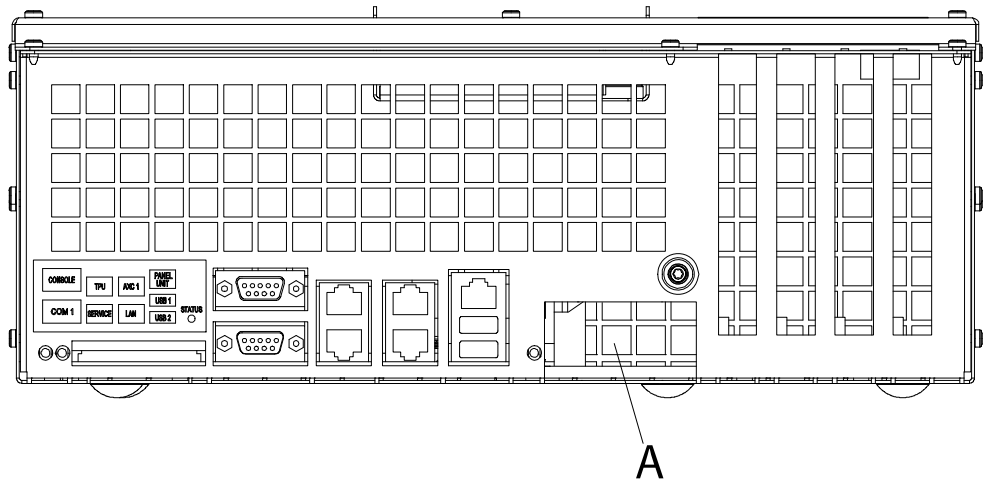

xx0700000162

A	Slot for fieldbus adapters
---	----------------------------

Required equipment

Equipment	Art. no.	Note
EtherNet/IP Fieldbus Adapter	3HAC027652-001	DSQC 669, Ethernet/IP communication is described in <i>Application manual - EtherNet/IP Fieldbus adapter</i>
PROFIBUS Fieldbus Adapter	3HAC026840-001	DSQC 667, PROFIBUS communication is described in <i>Application manual - PROFIBUS Fieldbus Adapter</i>
PROFINET Fieldbus Adapter	3HAC031670-001	DSQC 688, PROFINET communication is described in <i>Application manual - PROFINET Fieldbus Adapter</i>
Application manual - EtherNet/IP Fieldbus adapter	3HAC028509-001	Contains information on how to configure the system for Ethernet/IP Fieldbus Adapter DSQC 669.
Application manual - PROFIBUS Fieldbus Adapter	3HAC029338-001	Contains information on how to configure the system for PROFIBUS Fieldbus Adapter DSQC 667.

Continues on next page

4 Repair activities, controller IRC5



4.12. Replacement of fieldbus adapter in the computer unit DSQC639

Continued

Equipment	Art. no.	Note
Application manual - PROFINET Fieldbus Adapter	3HAC031974-001	Contains information on how to configure the system for PROFINET Fieldbus Adapter DSQC 688.
Standard toolkit		The contents are described in section <i>Standard toolkit, IRC5 on page 299</i> .
Circuit diagram		See <i>Circuit Diagram on page 319</i> .

Removal

The following procedure details how to remove the fieldbus adapter from the computer unit.

Action	Note/Illustration
1.  DANGER! Before commencing any work inside the cabinet, please observe the safety information in section <i>DANGER - Make sure that the main power has been switched off! on page 30</i> .	
2.  <small>esd</small> WARNING! The unit is sensitive to ESD. Before handling the unit please read the safety information in the section <i>WARNING - The unit is sensitive to ESD! on page 31</i>	
3. Remove the computer unit.	Detailed in section <i>Replacement of computer unit DSQC639 on page 200</i>
4. Open the computer unit.	Detailed in section <i>Replacement of motherboard in computer unit DSQC639 on page 204</i>
5. Identify the fieldbus adapter.	The barcode sticker contains information on type designation.
6. Disconnect the cable to/from the fieldbus adapter.	

© Copyright 2004-2010 ABB. All rights reserved.

Continues on next page

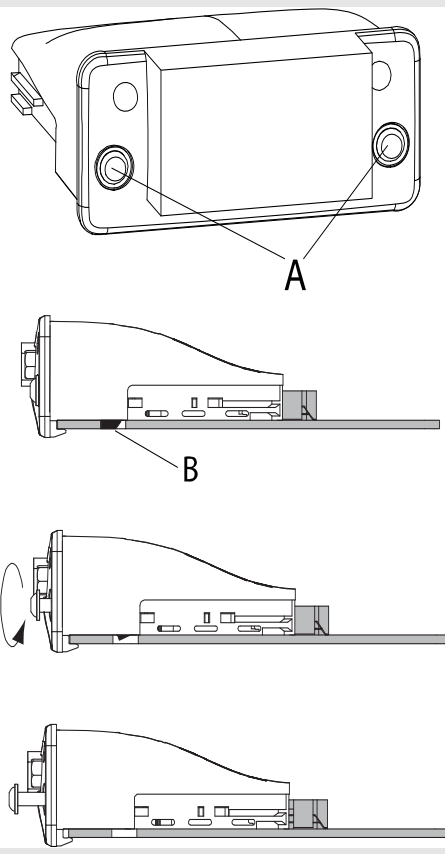
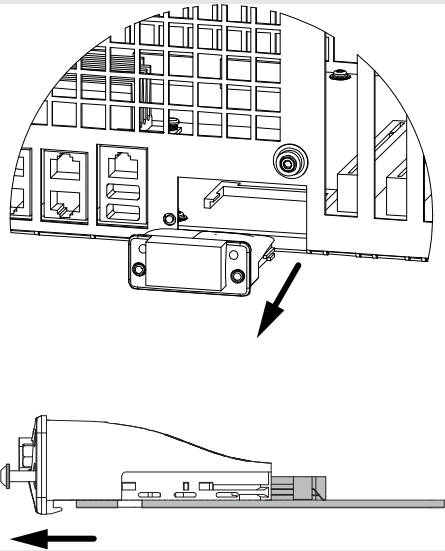
Action	Note/Illustration
<p>7. Loosen the attachment screws (2 pcs) on front of the fieldbus adapter to release the fastening mechanism.</p> <p> NOTE! Only loosen the attachment screws. Do not remove them.</p>	 <p>xx0700000193</p> <ul style="list-style-type: none"> • A: Attachment screws (2 pcs) • B: Fastening mechanism
<p>8. Grip the loosened attachment screws and gently pull the fieldbus adapter out in the direction of the arrow.</p>	 <p>xx0700000195</p>



4 Repair activities, controller IRC5

4.12. Replacement of fieldbus adapter in the computer unit DSQC639

Continued

Refitting

The following procedure details how to refit the fieldbus adapter in the computer unit.

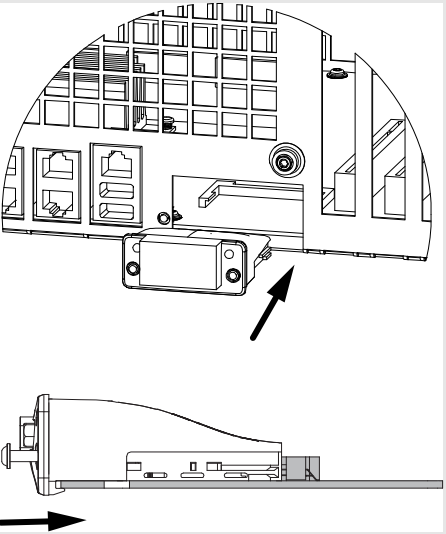
	Action	Note/Illustrator
1.	 DANGER! Before commencing any work inside the cabinet, please observe the safety information in section <i>DANGER - Make sure that the main power has been switched off!</i> on page 30.	
2.	 esd WARNING! The unit is sensitive to ESD. Before handling the unit please read the safety information in the section <i>WARNING - The unit is sensitive to ESD!</i> on page 31	
3.	Fit the fieldbus adapter in position by pushing the fieldbus adapter along the rails on the motherboard.  WARNING! Push carefully so no pins are damaged. Make sure that the adapter is pushed straight onto the rails.	<p>NOTE! Always grip the fieldbus adapter around the edges to avoid damage to the adapter or its components.</p>  xx070000194

© Copyright 2004-2010 ABB. All rights reserved.

Continued

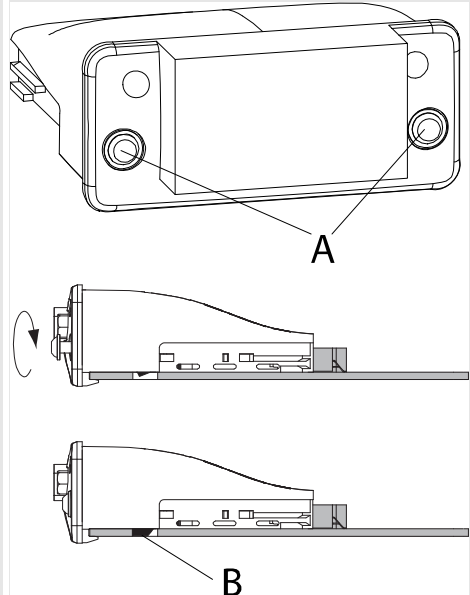
Action	Note/Illustrator
4. Secure it with its attachment screws (2 pcs) on front of the fieldbus adapter.	 <p style="font-size: small;">xx0700000201</p> <ul style="list-style-type: none"> • A: Attachment screws • B: Fastening mechanism
5. Reconnect the cable to the fieldbus adapter.	
6. Close the computer unit.	Detailed in section Replacement of motherboard in computer unit DSQC639 on page 204
7. Refit the computer unit.	Detailed in section Replacement of computer unit DSQC639 on page 200
8. Make sure the robot system is configured to reflect the fieldbus adapter installed.	

4 Repair activities, controller IRC5

4.13. Replacement of fan in computer unit DSQC639

4.13. Replacement of fan in computer unit DSQC639

Location

The computer fan is located as shown in the figure below.

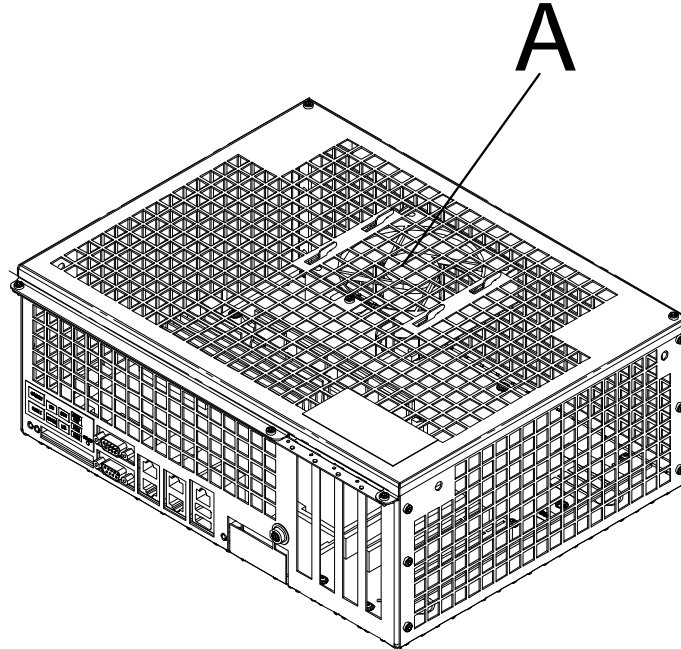

xx0600002917

A

Fan

Required equipment



Equipment	Note
Fan	See Computer unit DSQC 639 parts on page 305 .
Standard toolkit	The contents are defined in section Standard toolkit.
Other tools and procedures may be required. See references to these procedures in the step-by-step instructions below.	These procedures include references to the tools required.
Circuit diagram	See Circuit Diagram on page 319 .

© Copyright 2004-2010 ABB. All rights reserved.

Continues on next page

Removal

The procedure below details how to remove the fan in the computer unit.

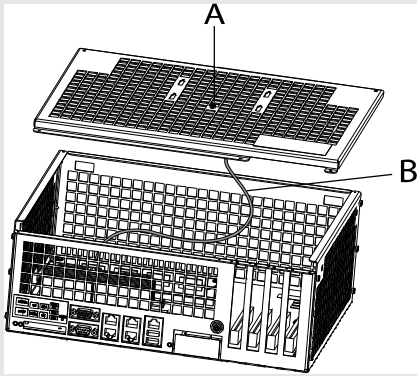
	Action	Note/Illustration
1.	 <p>DANGER! Before commencing any work inside the cabinet, please observe the safety information in section <i>DANGER - Make sure that the main power has been switched off!</i> on page 30.</p>	
2.	 <p>esd WARNING! The unit is sensitive to ESD. Before handling the unit please read the safety information in the section <i>WARNING - The unit is sensitive to ESD!</i> on page 31</p>	
3.	Remove the computer unit.	Detailed in section <i>Replacement of computer unit DSQC639</i> on page 200.
4.	Open the computer unit.  <p>WARNING! Be careful with the fan cable when opening and removing the cover plate. The fan cable must not be stretched.</p>	Detailed in section <i>Replacement of motherboard in computer unit DSQC639</i> on page 204.
5.	Disconnect the fan cable from the motherboard.	
6.	Remove the attachment screw.	 <p>xx0600002919</p> <ul style="list-style-type: none"> • A: attachment screw (1 pcs) • B: fan cable

4 Repair activities, controller IRC5

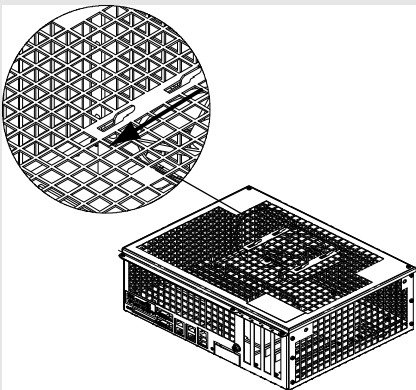

4.13. Replacement of fan in computer unit DSQC639

Continued

Action	Note/Illustration
7. Remove the fan from the cover plate in arrow direction.	 <p>xx0600002920</p>

Refitting

The procedure below details how to refit the fan in the computer unit.

Action	Note/Illustration
1.  DANGER! Before commencing any work inside the cabinet, please observe the safety information in section DANGER - Make sure that the main power has been switched off! on page 30.	
2.  esd WARNING! The unit is sensitive to ESD. Before handling the unit please read the safety information in the section WARNING - The unit is sensitive to ESD! on page 31	
3. Refit the fan on the cover plate.	
4. Refit the attachments screw.	
5. Reconnect the cable to the motherboard.	
6. Close the computer unit.	Detailed in section Replacement of motherboard in computer unit DSQC639 on page 204.
7. Refit the computer unit.	Detailed in section Replacement of computer unit DSQC639 on page 200.

© Copyright 2004-2010 ABB. All rights reserved.

4.14. Replacement of Compact Flash memory in computer unit DSQC639

Location

The Compact Flash memory is located in the computer unit as shown in the figure below.

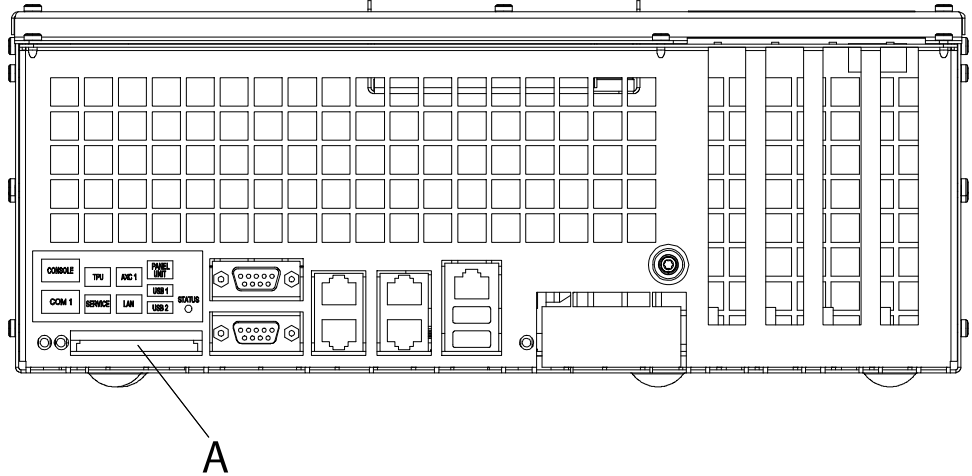

xx0600002922

A	Slot for Compact Flash memory
---	-------------------------------



NOTE!

Only use Compact flash memory supplied by ABB.

Required equipment

Equipment	Note
Compact Flash 1GB	DSQC 656 1GB NOTE! Only use Compact flash memory supplied by ABB. Includes <i>ABB boot image</i> software to correctly reboot the robot controller. See Computer unit DSQC 639 parts on page 305 .
Compact Flash 2GB	DSQC 656 2GB NOTE! Only use Compact flash memory supplied by ABB. Includes <i>ABB boot image</i> software to correctly reboot the robot controller. See Computer unit DSQC 639 parts on page 305 .
Standard toolkit	The content is described in section Standard toolkit, IRC5 on page 299 .
Other tools and procedures may be required. See references to these procedures in the step-by-step instructions below.	
Circuit diagram	See Circuit Diagram on page 319



4 Repair activities, controller IRC5

4.14. Replacement of Compact Flash memory in computer unit DSQC639

Continued

Removal

Use the following procedure to remove the Compact Flash memory from the computer unit.

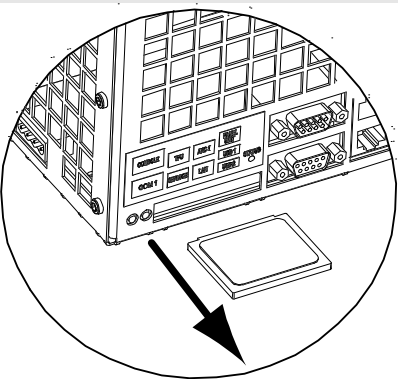

	Action	Note/illustration
1.	 DANGER! Before commencing any work inside the cabinet, please observe the safety information in section <i>DANGER - Make sure that the main power has been switched off!</i> on page 30.	
2.	 esd WARNING! The unit is sensitive to ESD. Before handling the unit please read the safety information in the section <i>WARNING - The unit is sensitive to ESD!</i> on page 31	
3.	Gently, pull the Compact Flash memory out in the direction of the arrow.	 xx0600002923

© Copyright 2004-2010 ABB. All rights reserved.

Continues on next page

Refitting

Use the following procedure to refit the Compact Flash memory in the computer unit.

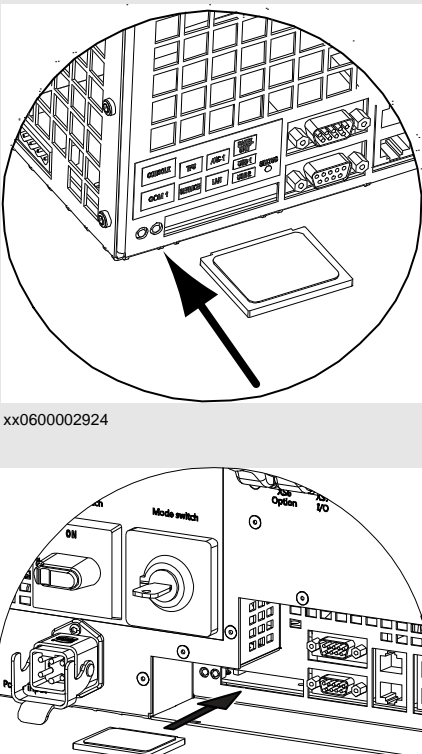
	Action	Note/Illustration
1.	 <p>DANGER! Before commencing any work inside the cabinet, please observe the safety information in section <i>DANGER - Make sure that the main power has been switched off!</i> on page 30.</p>	
2.	 <p>esd WARNING! The unit is sensitive to ESD. Before handling the unit please read the safety information in the section <i>WARNING - The unit is sensitive to ESD!</i> on page 31</p>	
3.	<p>Refit the Compact Flash memory.</p>	 <p>xx0600002924</p> <p>xx0900000608</p>

4 Repair activities, controller IRC5

4.15. Replacement of servo drive units, rectifier and capacitor unit (Drive System 04)

4.15. Replacement of servo drive units, rectifier and capacitor unit (Drive System 04)

Location

The illustration below shows the location of the servo drive units, rectifiers and capacitor units in a Single Cabinet Controller.

In the Dual Cabinet Controller the servo drive components are located in the Drive Module.

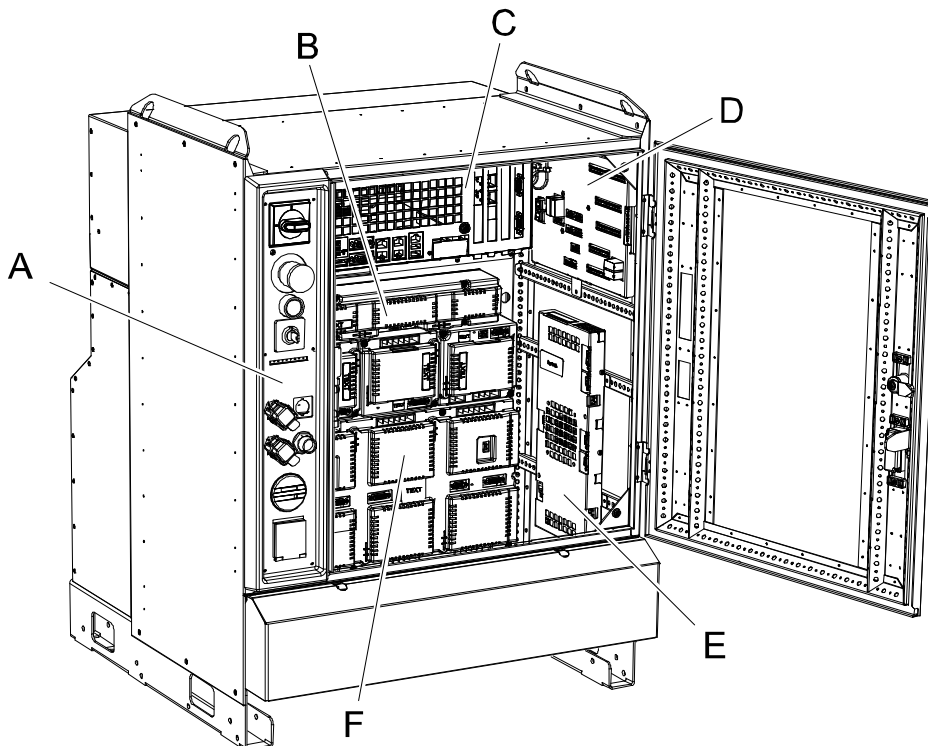

xx0500001858

A	Operator's panel
B	Capacitor
C	Computer unit
D	Panel board unit
E	Axis computer
F	Drive system (drive units and rectifier)

Configuration

The drive module exists in a number of versions, these are described in section [Configuration of Drive System 04, IRC5 on page 91](#)

4.15. Replacement of servo drive units, rectifier and capacitor unit (Drive System 04)

Continued

Required equipment

Equipment	Note
Drive units, rectifiers and capacitor units	Specified in section <i>Configuration of Drive System 04, IRC5 on page 91</i>
Standard toolkit	The contents are defined in section <i>Standard toolkit, IRC5 on page 299.</i>
Other tools and procedures may be required. See references to these procedures in the step-by-step instructions below.	These procedures include references to the tools required.
Circuit Diagram	See <i>Circuit Diagram on page 319.</i>

Removal

The procedure below details how to remove the servo drive units, rectifiers and capacitor units.

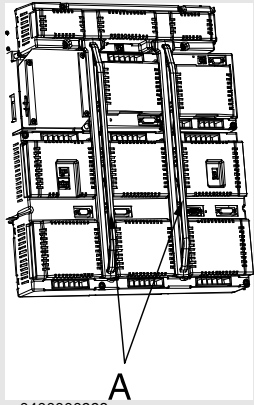
Action	Note/Illustration
<p>1.  DANGER! Before commencing any work inside the cabinet, please observe the safety information in section <i>DANGER - Make sure that the main power has been switched off! on page 30.</i></p>	
<p>2. If an EPS or SafeMove board (option <i>Electronic Position Switches</i> or <i>SafeMove</i>) is mounted the Axis computer unit needs to be removed before removal of the servo drive units, rectifiers and capacitors.</p>	<p>See <i>Replacement of EPS board DSQC 646 on page 238</i> or <i>Replacement of SafeMove board DSQC 647 on page 242.</i></p>
<p>3. Disconnect all connectors from the unit to be replaced.</p>	
<p>4. Remove the busbar between units.</p>	 <p>xx0400000998 Parts: • A: bus bar</p>

© Copyright 2004-2010 ABB. All rights reserved.

Continues on next page

4 Repair activities, controller IRC5

4.15. Replacement of servo drive units, rectifier and capacitor unit (Drive System 04)

Continued

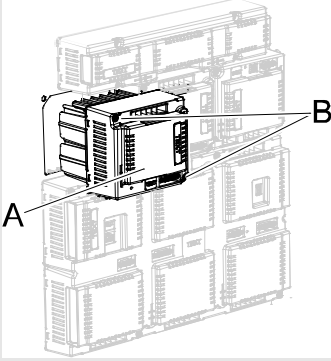
Action	Note/Illustration
5. Remove the drive unit after unscrewing its <i>attachment screws</i> .	 <p>xx0500002001</p> <p>Parts:</p> <ul style="list-style-type: none"> • A: drive unit • B: attachment screw

Refitting

The procedure below details how to refit the servo drive units, rectifiers and capacitor units.

Action	Note/Illustration
1.  DANGER! Before commencing any work inside the cabinet, please observe the safety information in section <i>DANGER - Make sure that the main power has been switched off!</i> on page 30.	
2. Fit the unit in its intended position and orientation. Secure it with its <i>attachment screws</i> .	
3. Reconnect all <i>busbars</i> between units.	
4. Reconnect any connectors disconnected at removal.	
5. Refit the Axis computer unit if it was removed before the drive unit was removed.	See <i>Replacement of EPS board DSQC 646</i> on page 238 or <i>Replacement of SafeMove board DSQC 647</i> on page 242.

© Copyright 2004-2010 ABB. All rights reserved.

4.16. Replacement of drive units (Drive System 09)

Location

The illustration shows the location of drive units in a Single Cabinet Controller.

In the Dual Cabinet Controller the servo drive components are located in the Drive Module.

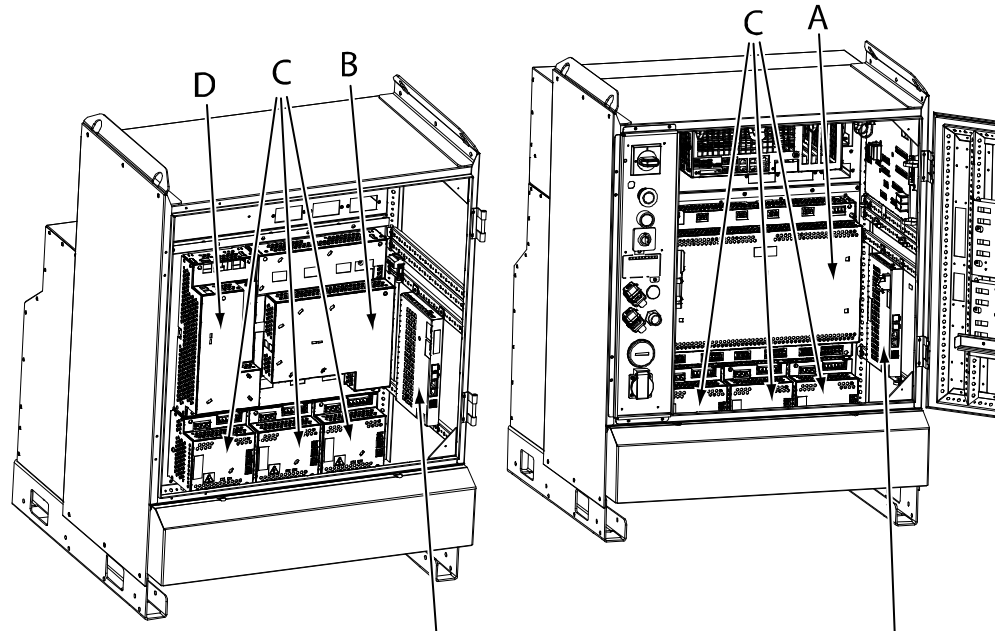

xx1000000001

A	Main Drive Unit for large robots
B	Main Drive Unit for small robots
C	Additional Drive Units (for additional axes)
D	Additional Rectifier Unit (only used for additional axes in combination with small robots)

Configuration

The drive module exists in a number of versions, these are described in section [Configuration of Drive System 09, IRC5 on page 98](#).

Required equipment

Equipment	Note
Drive units	Specified in section Configuration of Drive System 09, IRC5 on page 98 .
Standard toolkit	The contents are defined in section Standard toolkit, IRC5 on page 299 .
Other tools and procedures may be required. See references to these procedures in the step-by-step instructions below.	These procedures include references to the tools required.
Circuit Diagram	See Circuit Diagram on page 319 .

Continues on next page

4 Repair activities, controller IRC5

4.16. Replacement of drive units (Drive System 09)

Continued

Removal

The procedure below details how to remove the Main Drive Unit and the Additional Drive Units. If your drive system contains an Additional Rectifier Unit, it is replaced in a similar way.

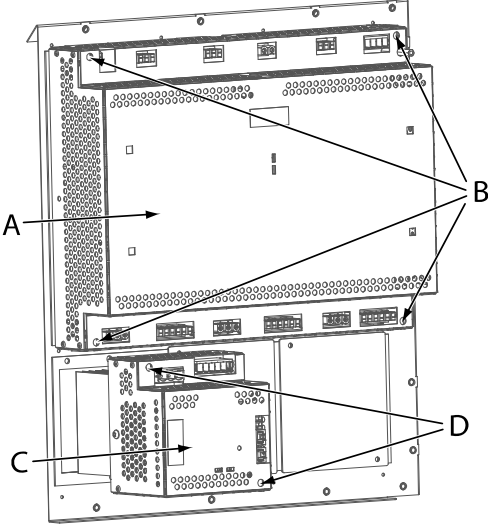
	Action	Note/Illustration
1.	 DANGER! Before any work inside the cabinet, please observe the safety information in section <i>DANGER - Make sure that the main power has been switched off!</i> on page 30.	
2.	If an EPS or SafeMove board (option <i>Electronic Position Switches</i> or <i>SafeMove</i>) is mounted, the Axis computer unit must be removed before removal of the Main Drive Unit.	See <i>Replacement of EPS board DSQC 646</i> on page 238 or <i>Replacement of SafeMove board DSQC 647</i> on page 242.
3.	Disconnect all connectors from the unit to be replaced.	
4.	Remove the drive unit after unscrewing its attachment screws.	 <p>xx090000025</p> <p>Parts:</p> <ul style="list-style-type: none">• A: Main Drive Unit• B: Attachment screws for MDU• C: Additional Drive Unit• D: Attachment screws for ADU

© Copyright 2004-2010 ABB. All rights reserved.

Continues on next page

Refitting

The procedure below details how to refit the drive units.

	Action	Note/Illustration
1.	 <p>DANGER! Before commencing any work inside the cabinet, please observe the safety information in section <i>DANGER - Make sure that the main power has been switched off!</i> on page 30.</p>	
2.	Fit the unit in its intended position and orientation. Secure it with its <i>attachment screws</i> .	
3.	Reconnect any connectors disconnected at removal.	
4.	Refit the Axis computer unit if it was removed before the drive unit was removed.	See <i>Replacement of EPS board DSQC 646 on page 238</i> or <i>Replacement of SafeMove board DSQC 647 on page 242</i> .

4 Repair activities, controller IRC5

4.17. Replacement of Axis computer DSQC 601 (Drive System 04)

4.17. Replacement of Axis computer DSQC 601 (Drive System 04)

Location

The illustration below shows the location of the axis computer in the Single Cabinet Controller.

In the Dual Cabinet Controller the axis computer is located in the Drive Module.

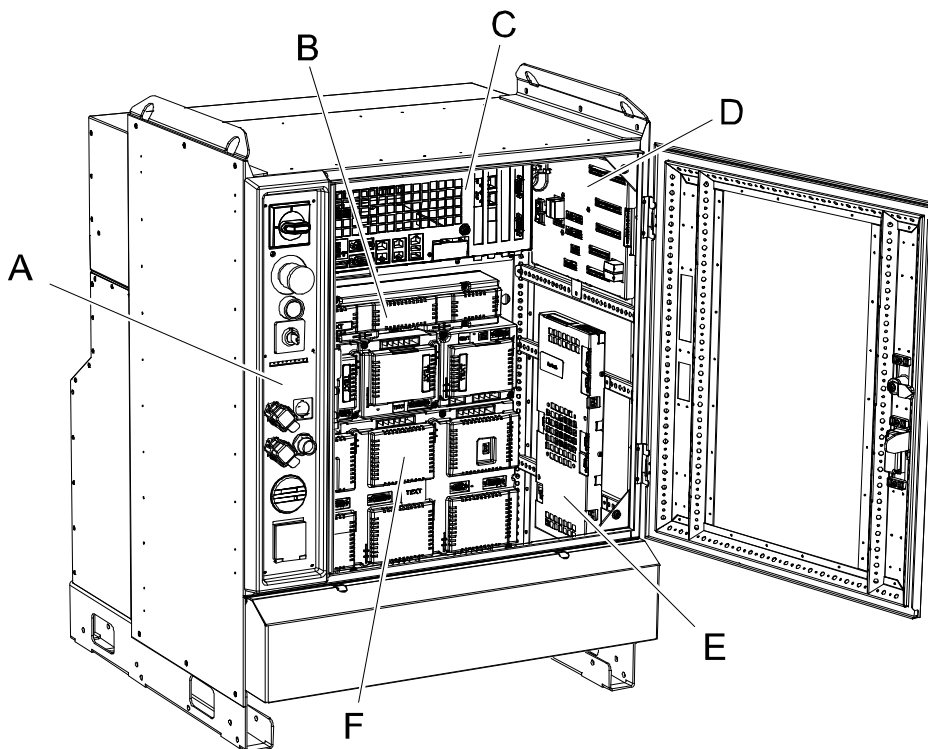

xx0500001858



A	Operator's panel
B	Capacitor
C	Computer unit
D	Panel board unit
E	Axis computer
F	Drive system (drive units and rectifier)

© Copyright 2004-2010 ABB. All rights reserved.

Continues on next page

Removal

The procedure below details how to remove the axis computer.

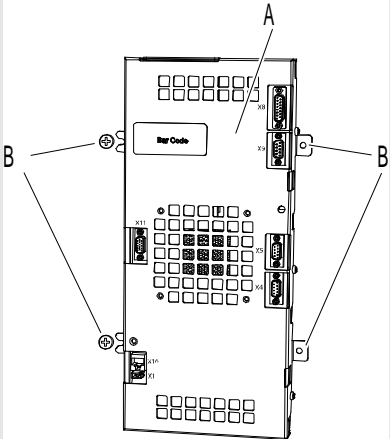
	Action	Note/Illustration
1.	 <p>DANGER! Before commencing any work inside the cabinet, please observe the safety information in section <i>DANGER - Make sure that the main power has been switched off!</i> on page 30.</p>	
2.	 <p>esd WARNING! The unit is sensitive to ESD. Before handling the unit please read the safety information in the section <i>WARNING - The unit is sensitive to ESD!</i> on page 31</p>	
3.	Disconnect all connectors from the axis computer.	NOTE! Make a note of any connections,
4.	Remove the attachment screws.	 <p>xx0500002002</p> <ul style="list-style-type: none"> • A: axis computer • B: attachment screws
5.	Remove the axis computer.	

4 Repair activities, controller IRC5

4.17. Replacement of Axis computer DSQC 601 (Drive System 04)

Continued

Refitting

The procedure below details how to refit the axis computer.

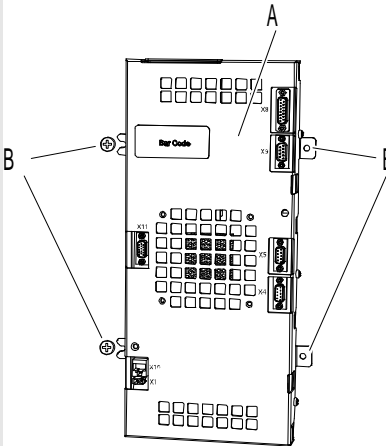
	Action	Note/Illustration
1.	 <p>DANGER! Before commencing any work inside the cabinet, please observe the safety information in section <i>DANGER - Make sure that the main power has been switched off!</i> on page 30.</p>	
2.	Fit the new axis computer.	 <p>xx0500002002</p> <ul style="list-style-type: none"> • A: axis computer • B: attachment screws
3.	Refit the <i>attachment screws</i> .	
4.	Reconnect all the connectors.	

4.18. Replacement of Axis computer DSQC 668 (Drive System 09)

Location

The illustration below shows the location of the axis computer in the Single Cabinet Controller.

In the Dual Cabinet Controller the axis computer is located in the Drive Module.

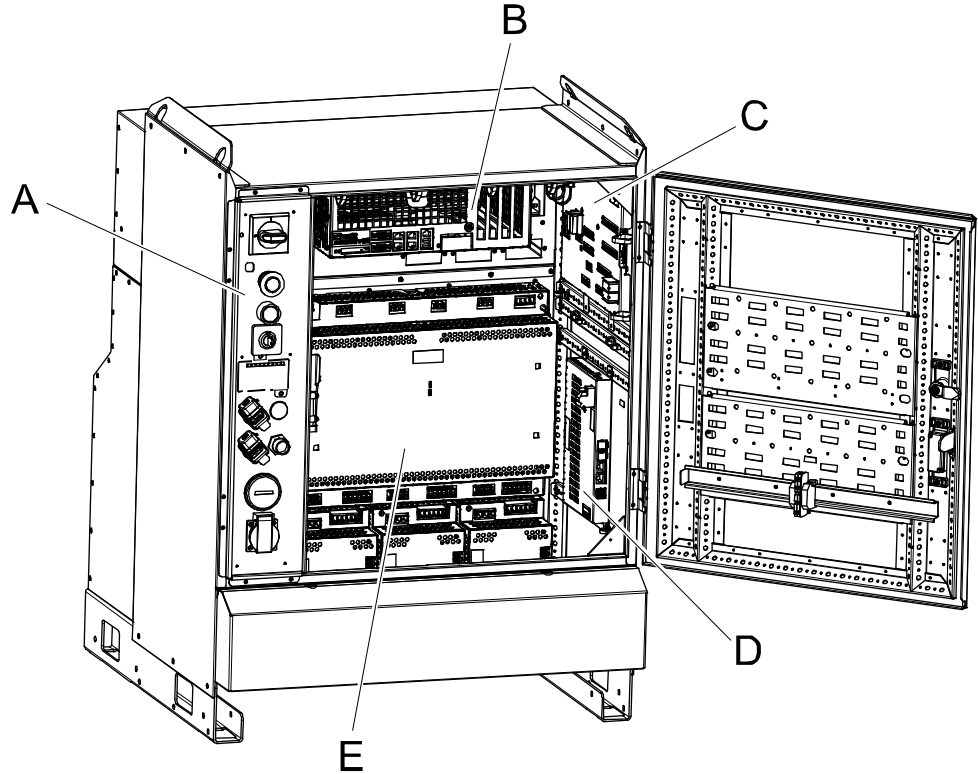

en080000476

A	Operator's panel
B	Computer unit
C	Panel board
D	Axis computer
E	Drive system



4 Repair activities, controller IRC5

4.18. Replacement of Axis computer DSQC 668 (Drive System 09)

Continued

Removal

The procedure below details how to remove the axis computer.

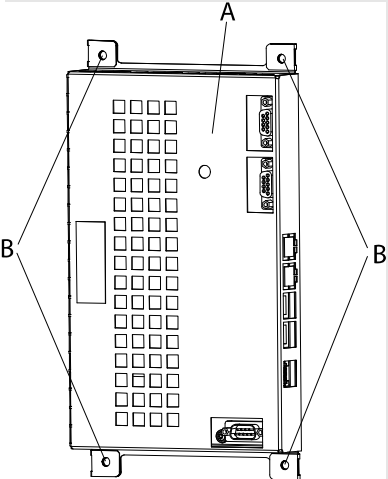
	Action	Note/Illustration
1.	 <p>DANGER! Before commencing any work inside the cabinet, please observe the safety information in section <i>DANGER - Make sure that the main power has been switched off!</i> on page 30.</p>	
2.	 <p>esd</p> <p>WARNING! The unit is sensitive to ESD. Before handling the unit please read the safety information in the section <i>WARNING - The unit is sensitive to ESD!</i> on page 31</p>	
3.	Disconnect all connectors from the axis computer.	<p>NOTE! Make a note of any connections,</p>
4.	Remove the attachment screws.	 <p>xx0900000030</p> <ul style="list-style-type: none"> • A: axis computer • B: attachment screws
5.	Remove the axis computer.	

© Copyright 2004-2010 ABB. All rights reserved.

Continues on next page

Refitting

The procedure below details how to refit the axis computer.

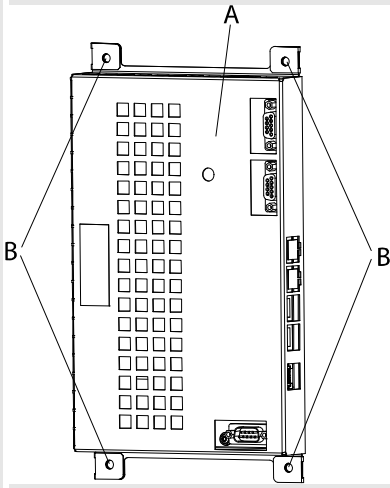
	Action	Note/Illustration
1.	 <p>DANGER! Before commencing any work inside the cabinet, please observe the safety information in section <i>DANGER - Make sure that the main power has been switched off!</i> on page 30.</p>	
2.	Fit the new axis computer.	 <p style="font-size: small;">xx0900000030</p> <ul style="list-style-type: none"> • A: axis computer • B: attachment screws
3.	Refit the attachment screws.	
4.	Reconnect all the connectors.	

4 Repair activities, controller IRC5

4.19. Replacement of EPS board DSQC 646

4.19. Replacement of EPS board DSQC 646

General

An EPS board is mounted in the Single Cabinet Controller or Drive Module if the option Electronic Position Switches is used.

Location

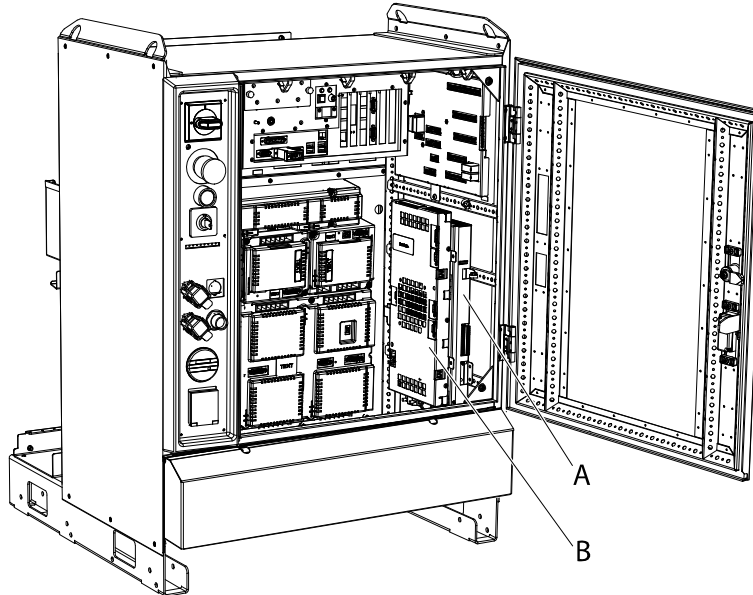

The EPS board is mounted behind the axis computer.



xx0600003203

A	EPS board
B	Axis computer

Removal

	Action	Note/illustration
1.	 <p>DANGER! Before any work inside the cabinet, please observe the safety information in section <i>DANGER - Make sure that the main power has been switched off!</i> on page 30.</p>	
2.	 <p>esd WARNING! The unit is sensitive to ESD, before handling the unit please observe the safety information in section <i>WARNING - The unit is sensitive to ESD!</i> on page 31</p>	

© Copyright 2004-2010 ABB. All rights reserved.

Continues on next page

Continued

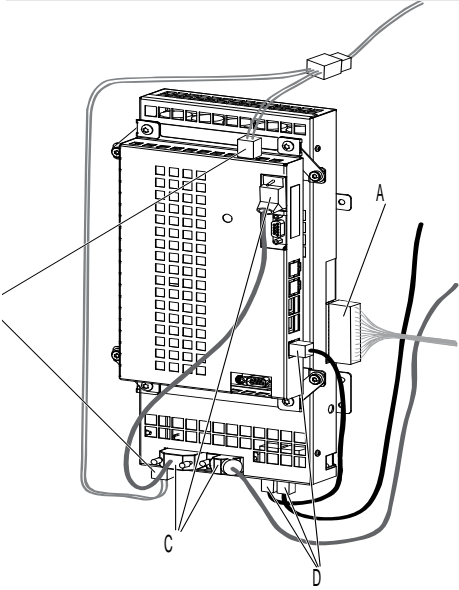
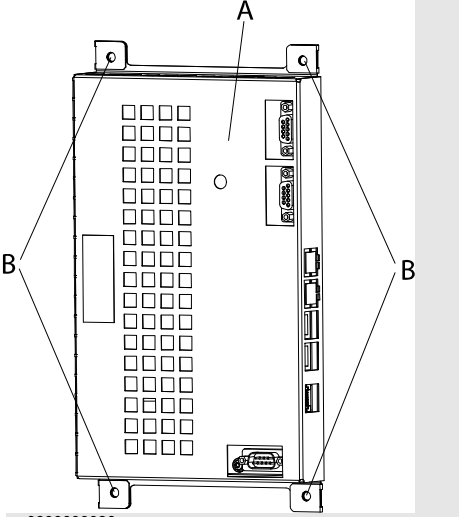
Action	Note/illustration
<p>3. Disconnect the following cables connected to the EPS board and axis computer:</p> <ul style="list-style-type: none"> • Plug contact in I/O connector • Power cables • SMB cables • Ethernet cables 	 <p>xx0700000101</p> <ul style="list-style-type: none"> A: Plug contact in I/O connector B: Power cables C: SMB cables D: Ethernet cables
<p>4. Remove the attachment screws of the axis computer and remove the axis computer.</p>	 <p>xx0900000030</p> <ul style="list-style-type: none"> • A: axis computer • B: attachment screws

4 Repair activities, controller IRC5

4.19. Replacement of EPS board DSQC 646

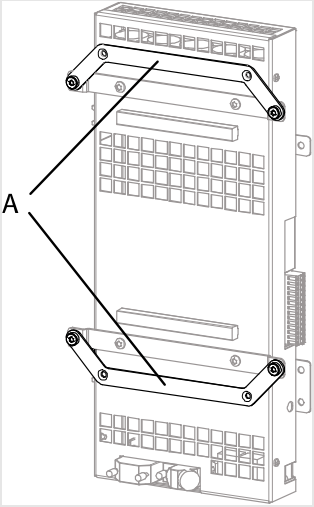
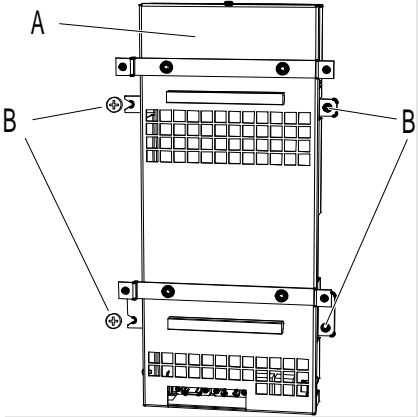

Continued

Action	Note/illustration
5. If the EPS board is used together with axis computer DSQC 668 (used with Drive System 09) two mounting brackets are mounted on the EPS board. Remove these and save them so the can be used on the new EPS board.	 <p>xx0900000436</p> <ul style="list-style-type: none">• A: Mounting brackets
6. Remove the attachment screws of the EPS board and remove the EPS board.	 <p>xx0600003204</p> <ul style="list-style-type: none">• A: EPS board• B: attachment screws

© Copyright 2004-2010 ABB. All rights reserved.

Continues on next page

Refitting

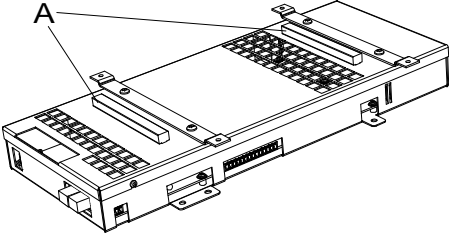
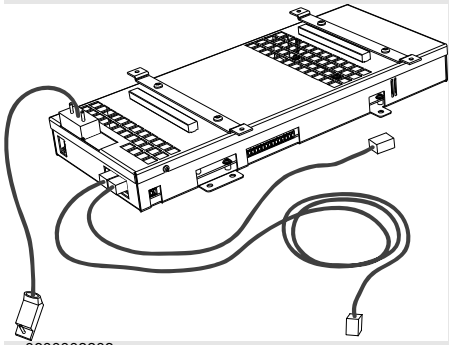
	Action	Note/illustration
1.	 <p>DANGER! Before commencing any work inside the cabinet, please observe the safety information in section <i>DANGER - Make sure that the main power has been switched off!</i> on page 30.</p>	
2.	 <p>esd WARNING! The unit is sensitive to ESD. Before handling the unit please read the safety information in the section <i>WARNING - The unit is sensitive to ESD!</i> on page 31</p>	
3.	<p>If not already in place, fit the EMC strips on the EPS board.</p>	
4.	<p>Connect the short SMB cable and both Ethernet cables to the EPS board before mounting the board. These connections may be difficult to reach once the board is mounted.</p> <p>The two Ethernet connectors on the EPS board are interchangeable (it does not matter which is connected to the main computer and which is connected to the axis computer).</p>	
5.	<p>Refit the EPS board and the axis computer (see <i>Removal on page 238</i>).</p>	
6.	<p>Refit all the cables (see <i>Removal on page 238</i>).</p>	

4 Repair activities, controller IRC5

4.20. Replacement of SafeMove board DSQC 647

4.20. Replacement of SafeMove board DSQC 647

General

A SafeMove board is mounted in the Single Cabinet Controller or Drive Module if the option SafeMove is used.



NOTE!

After replacement of the safety controller, the SafeMove configuration must be downloaded to the new safety controller and then validated. For more information, see *Application manual - SafeMove*

Location

The SafeMove board is mounted behind the axis computer.

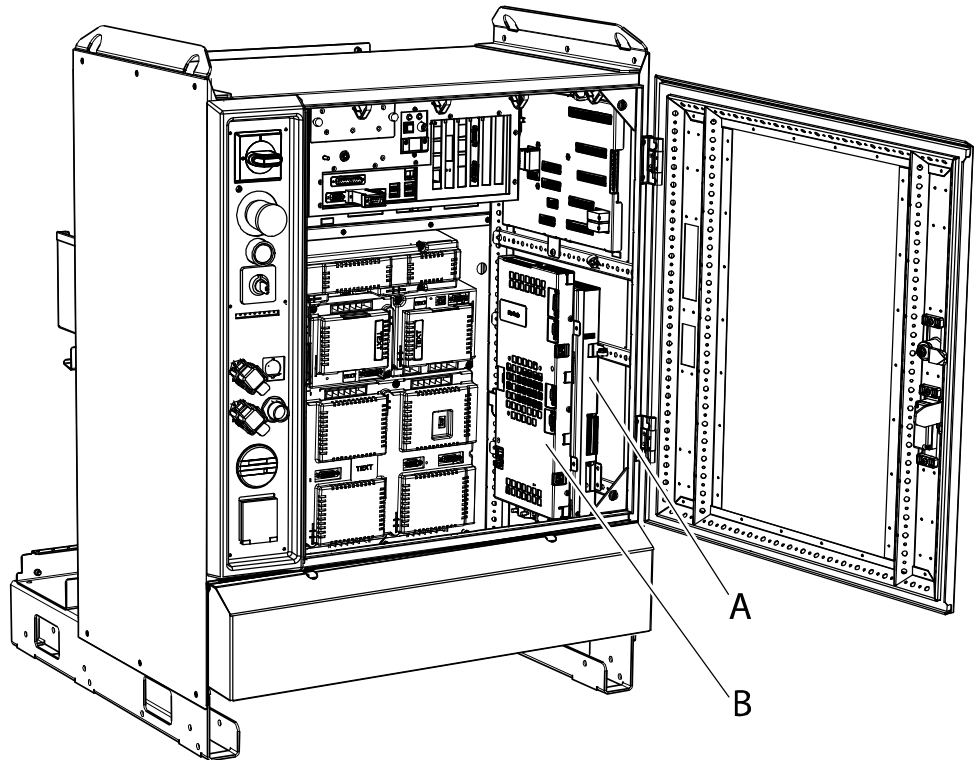

xx080000102



A	SafeMove board
B	Axis computer

© Copyright 2004-2010 ABB. All rights reserved.

Continues on next page

Removal

The procedure below details how to remove the SafeMove board.

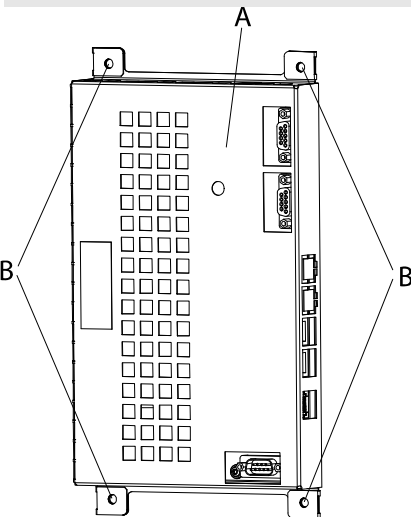
	Action	Note/illustration
1.	 <p>DANGER! Before commencing any work inside the cabinet, please observe the safety information in section <i>DANGER - Make sure that the main power has been switched off!</i> on page 30.</p>	
2.	 <p>WARNING! The unit is sensitive to ESD, before handling the unit please observe the safety information in section <i>The unit is sensitive to ESD!</i> on page 27.</p>	
3.	<p>Disconnect the cables connected to the SafeMove board and the cables between the SafeMove board and the axis computer:</p>	
4.	<p>Remove the attachment screws of the axis computer and remove the axis computer.</p>	 <p>xx0900000030</p> <ul style="list-style-type: none"> • A: axis computer • B: attachment screws (4 pcs)

4 Repair activities, controller IRC5

4.20. Replacement of SafeMove board DSQC 647

Continued

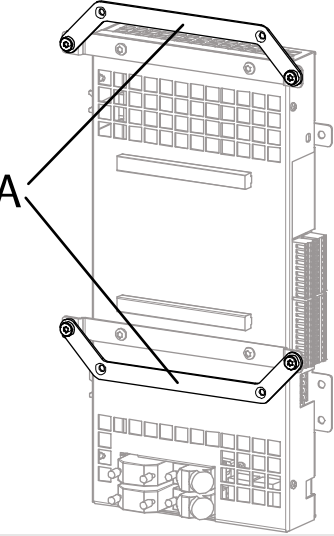
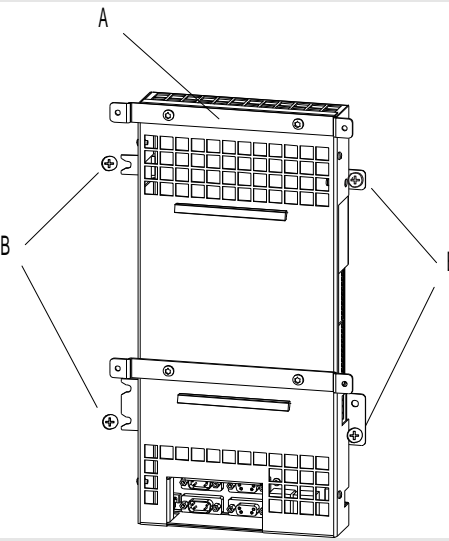

Action	Note/illustration
5. If the SafeMove board is used together with axis computer DSQC 668 (used with Drive System 09) two mounting brackets are mounted on the SafeMove board. Remove these and save them so they can be used on the new SafeMove board.	 <p>xx0900000439</p> <ul style="list-style-type: none">• A: Mounting brackets
6. Remove the attachment screws of the SafeMove board and remove the SafeMove board.	 <p>xx0800000104</p> <ul style="list-style-type: none">• A: SafeMove board• B: attachment screws (4 pcs)

© Copyright 2004-2010 ABB. All rights reserved.

Continues on next page

Refitting

The procedure below details how to refit the SafeMove board.

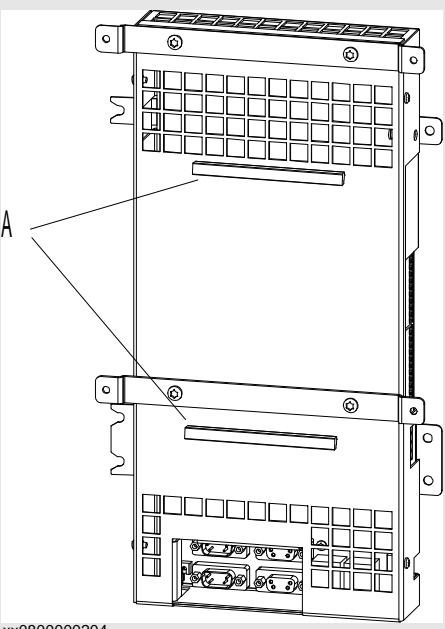
	Action	Note/illustration
1.	 <p>DANGER! Before commencing any work inside the cabinet, please observe the safety information in section <i>DANGER - Make sure that the main power has been switched off!</i> on page 30.</p>	
2.	 <p>WARNING! The unit is sensitive to ESD, before handling the unit please observe the safety information in section <i>The unit is sensitive to ESD!</i> on page 27.</p>	
3.	<p>If not already in place, fit the EMC strips on the SafeMove board.</p>	 <p>xx0800000204</p> <ul style="list-style-type: none"> • A: EMC strips

4 Repair activities, controller IRC5

4.20. Replacement of SafeMove board DSQC 647

Continued

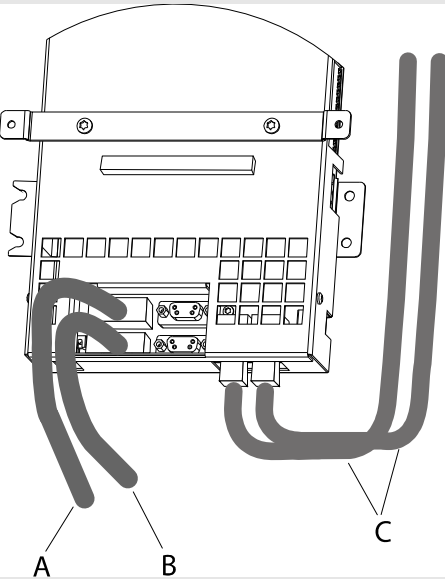
Action	Note/illustration
<p>4. Connect both SMB cables and both Ethernet cables to the SafeMove board before mounting the board. These connections may be difficult to reach once the board is mounted.</p> <p>The two Ethernet connectors on the SafeMove board are interchangeable (it does not matter which is connected to the main computer and which is connected to the axis computer).</p>	 <p>xx0800000103</p> <ul style="list-style-type: none">• A: SMB1 cable• B: SMB2 cable• C: Ethernet cables
5. Refit the SafeMove board and the axis computer, see Removal on page 243 .	
6. Refit all cables, see Removal on page 243 .	
7. After replacement of the safety controller, the SafeMove configuration must be downloaded to the new safety controller and then validated. For more information, see <i>Application manual - SafeMove</i>	

4.21. Replacement of Remote Service box

General

A Remote Service box is mounted in the Single Cabinet Controller or in the Control Module of the Dual Cabinet Controller if option Remote Service is used.

Location

The illustration below shows the Remote Service box in the Single Cabinet Controller. For Dual Cabinet Controller the Remote Service box is located on the bottom of the Control Module.

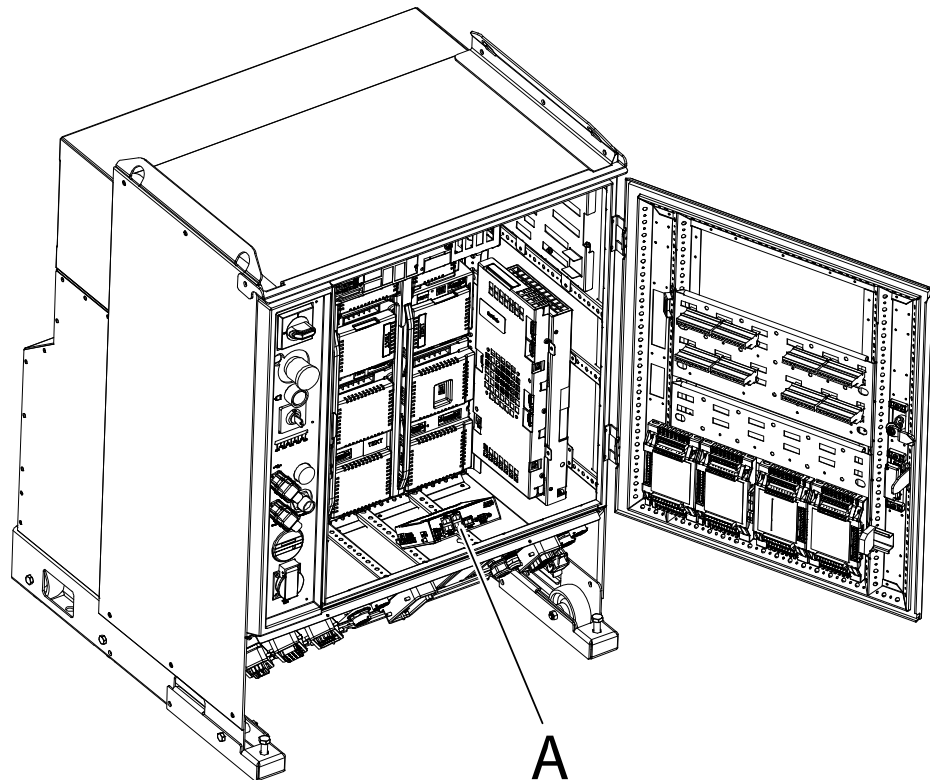

xx080000094

A Remote Service box

Required equipment

Equipment	Note
Remote Service box	DSQC 680 See Controller system parts (Drive System 04) on page 301.
Standard toolkit	The contents are defined in section Standard toolkit.
Other tools and procedures may be required. See references to these procedures in the step-by-step instructions below.	
Circuit diagram	See Circuit Diagram on page 319.

Continues on next page



4 Repair activities, controller IRC5

4.21. Replacement of Remote Service box

Continued

Removal

Use this procedure to remove the Remote Service box.

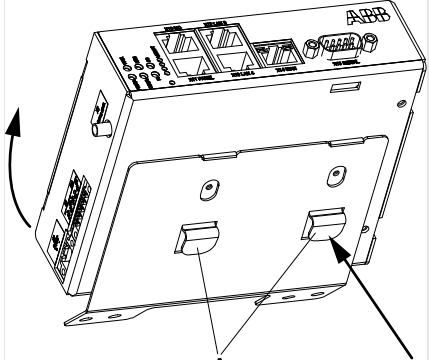
	Action	Note/illustration
1.	 <p>DANGER! Before commencing any work inside the cabinet, please observe the safety information in section <i>DANGER - Make sure that the main power has been switched off!</i> on page 30.</p>	
2.	 <p>WARNING! The unit is sensitive to ESD, before handling the unit please observe the safety information in section <i>The unit is sensitive to ESD!</i> on page 27.</p>	
3.	Disconnect all connectors from the Remote Service box.	
4.	Push the spring locks in the arrow direction and lift the box out.	 <p>xx0800000091</p> <ul style="list-style-type: none"> A: Spring lock

Refitting

Use this procedure to refit the Remote Service box.

	Action	Note/illustration
1.	 <p>DANGER! Before commencing any work inside the cabinet, please observe the safety information in section <i>DANGER - Make sure that the main power has been switched off!</i> on page 30.</p>	

© Copyright 2004-2010 ABB. All rights reserved.

Continues on next page

Continued

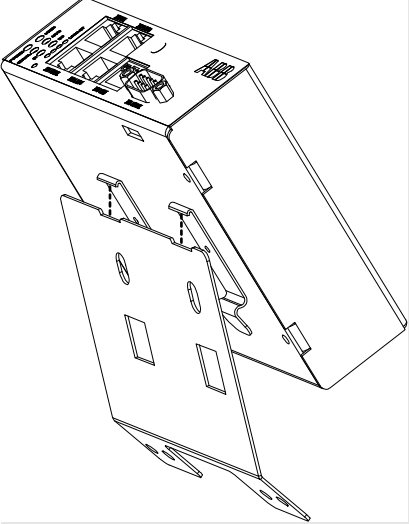
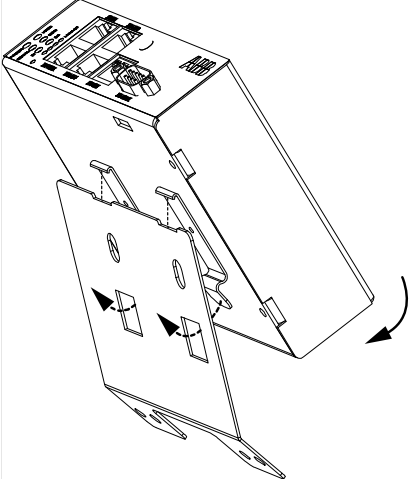
	Action	Note/illustration
2.	 <p>WARNING! The unit is sensitive to ESD, before handling the unit please observe the safety information in section <i>The unit is sensitive to ESD!</i> on page 27.</p>	
3.	Fit the Remote Service box in position.	 <p>xx0800000092</p>
4.	Push the Remote Service box in the arrow direction until the spring locks snaps into position.	 <p>xx0800000093</p>
5.	Reconnect all connectors to the Remote Service box.	

4 Repair activities, controller IRC5

4.22. Replacement of integrated PLC

4.22. Replacement of integrated PLC

General

As an option, the PLC AC500 can be integrated in the IRC5 controller. AC500 is built up by modules. Each module can easily be removed from its terminal base and be replaced. Removing the terminal base must be done from right to left.

Location

The integrated PLC is located on the inside of the IRC5 cabinet door.

Remove module from terminal base

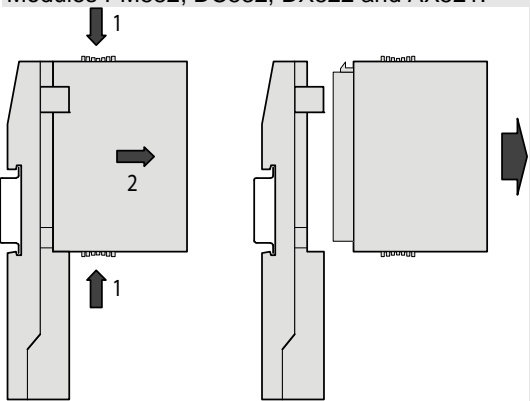
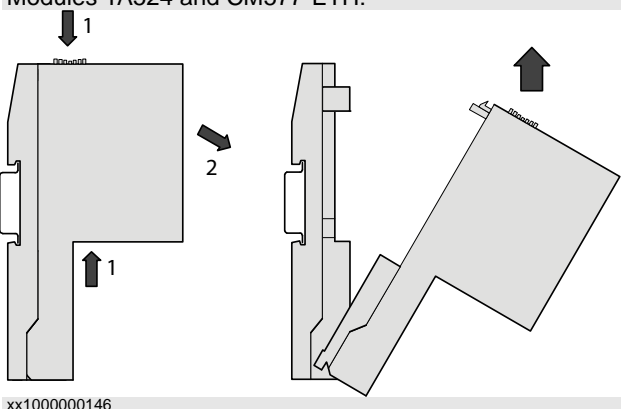
Action	Info
1. Disconnect all connectors from the module.	
2. Press the buttons on top and under the module and pull it out.	<p>Modules PM582, DC532, DX522 and AX521:</p>  <p>Modules TA524 and CM577-ETH:</p>  <p>xx1000000145</p> <p>xx1000000146</p>

© Copyright 2004-2010 ABB. All rights reserved.

Continues on next page

Remove terminal base

Only the right most terminal base can be removed. To remove one in the middle, all terminal bases to the right of it must be removed first.

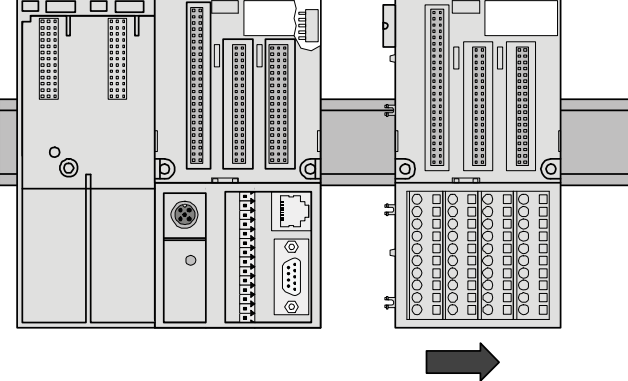
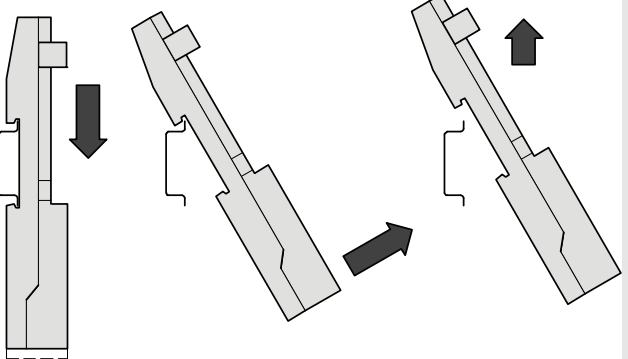
Action	Info
<ol style="list-style-type: none"> 1. Pull the terminal base to the right to disconnect it from the base to its left. 	 <p>xx1000000147</p>
<ol style="list-style-type: none"> 2. Press the module down and bend the lower part out. 	 <p>xx1000000148</p>

Refitting of terminal base

Action
<ol style="list-style-type: none"> 1. Snap the terminal base to the DIN rail.
<ol style="list-style-type: none"> 2. Push the terminal base to the left and connect it to the base to its left.

Refitting the module on the terminal base

Action
<ol style="list-style-type: none"> 1. Push the module into the terminal base socket. The terminal base is keyed so that only the correct module fits.
<ol style="list-style-type: none"> 2. Reconnect all connectors.

More information

For more information about the AC500 and its modules, see documentation for AC500.

4 Repair activities, controller IRC5

4.23. Replacement of Contactor Interface Board

4.23. Replacement of Contactor Interface Board

Location

The contactor interface board is located on the left wall in the Single Cabinet Controller.
In the Dual Cabinet Controller the contactor interface board is located on the left wall in the Drive Module.

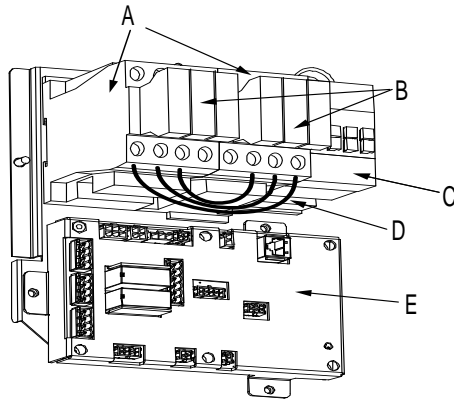

xx0400001058



A	MOTOR ON contactor K42
B	MOTOR ON contactor K43
C	Brake contactor
D	Jumpers (3pcs)
E	Contactor interface board

Required equipment

Equipment	Note
Contactor Interface board	DSQC 611 See <i>Controller system parts (Drive System 04)</i> on page 301.
Standard toolkit	The contents are defined in section Standard toolkit!
Other tools and procedures may be required. See references to these procedures in the step-by-step instructions below.	These procedures include references to the tools required.
Circuit Board	See <i>Circuit Diagram</i> on page 319.

Removal

The procedure below details how to remove the contactor board.

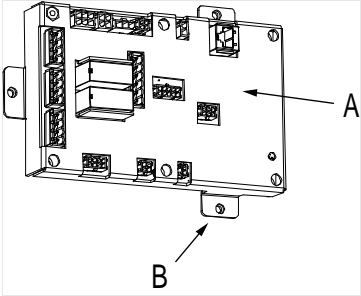
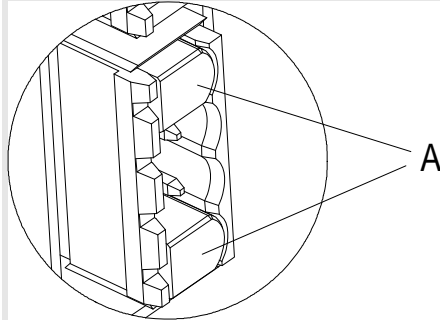
	Action	Note/Illustration
1.	 <p>DANGER! Before commencing any work inside the cabinet, please observe the safety information in section <i>DANGER - Make sure that the main power has been switched off!</i> on page 30.</p>	
2.	 <p>esd WARNING! The unit is sensitive to ESD. Before handling the unit please read the safety information in the section <i>WARNING - The unit is sensitive to ESD!</i> on page 31</p>	
3.	Disconnect all connectors.	<p>NOTE! Make a note of any connections.</p>
4.	Refit the attachment screws.	 <p>xx0400001062</p> <ul style="list-style-type: none"> • A: contactor interface board • B: attachment screws
5.	<p>Remove the contactor interface board.</p> <p>6. If SafeMove option is used, the plugs in the limit switch override contact (X23) pin 1 and 4, must be moved to the new contactor interface board. Use a small flat pliers to remove the plugs.</p>	 <p>xx0800000035</p> <ul style="list-style-type: none"> • A: plug (2 pcs)



4 Repair activities, controller IRC5

4.23. Replacement of Contactor Interface Board

Continued

Refitting

The procedure below details how to refit the contactor board.

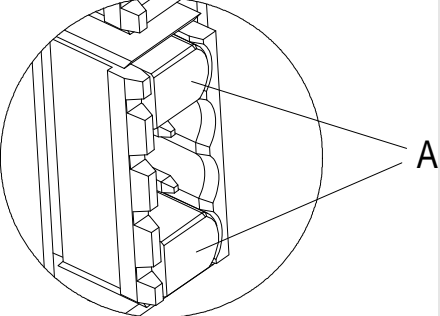
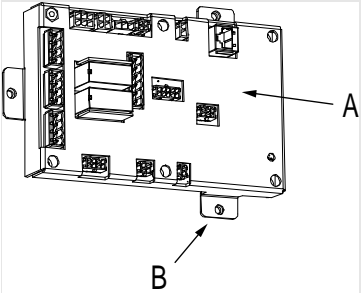
Action	Note/Illustration
1.  DANGER! Before commencing any work inside the cabinet, please observe the safety information in section <i>DANGER - Make sure that the main power has been switched off!</i> on page 30.	
2.  esd WARNING! The unit is sensitive to ESD. Before handling the unit please read the safety information in the section <i>WARNING - The unit is sensitive to ESD!</i> on page 31	
3. If SafeMove is used, mount the plugs in the limit switch override contact (X23) pin 1 and 4.	The limit switch override contact must be plugged and not used when using SafeMove.  xx0800000035 <ul style="list-style-type: none"> A: plug (2 pcs)
4. Refit the contactor interface board.	
5. Refit the attachment screws.	 xx0400001062 <ul style="list-style-type: none"> A: contactor interface board B: attachment screws
6. Reconnect all connectors.	

© Copyright 2004-2010 ABB. All rights reserved.

4.24. Replacement of drive system fans

Location

The illustration below shows the drive system fans in the Single Cabinet Controller.

In the Dual Cabinet Controller the drive system fans are located in the back of the Drive Module.

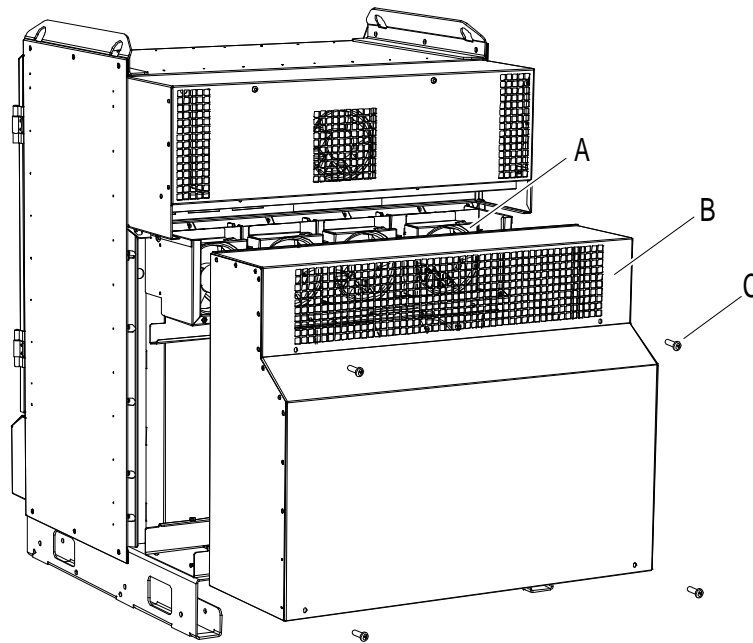

xx0500002011

A	Fan (4 pcs)
B	Cover
C	Attachment screw (4 pcs)

Required equipment

Equipment	Note
Fan with receptacle	See Miscellaneous parts on page 306 .
Standard toolkit	The contents are defined in section Standard toolkit.
Other tools and procedures may be required. see references to these procedures in the step-by-step instructions below.	These procedures include references to the tools required.
Circuit diagram	See Circuit Diagram on page 319 .

4 Repair activities, controller IRC5

4.24. Replacement of drive system fans

Continued

Removal

The following procedures details how to remove the drive system fan.

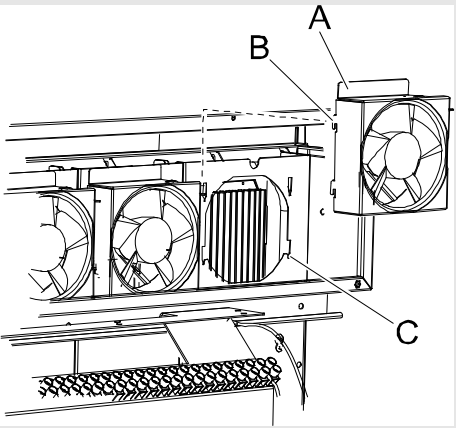
	Action	Note /illustration
1.	 <p>DANGER! Before commencing any work inside the cabinet, please observe the safety information in section <i>DANGER - Make sure that the main power has been switched off!</i> on page 30.</p>	
2.	Remove the moist dust filter magazine. (Option)	How to remove the moist dust filter magazine is detailed in section <i>Replacement of moist dust filter</i> on page 171.
3.	Loosen the four attachment screws to the cover.	
4.	Remove the cover.	
5.	Disconnect the connector to the fan.	
6.	Push the fan upwards and remove it.	 <p>xx0500002015</p> <ul style="list-style-type: none"> • A: fan • B: attachments • C: grooves

© Copyright 2004-2010 ABB. All rights reserved.

Continues on next page

Refitting

The following procedures details how to refit the drive system fan.

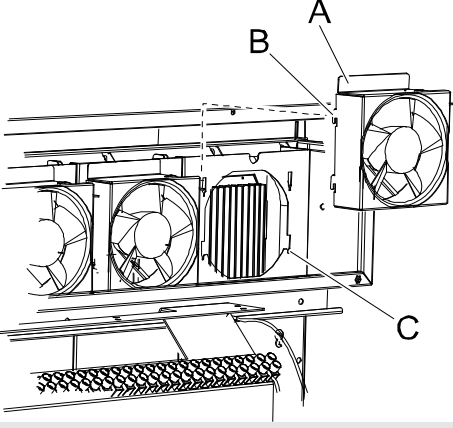
	Action	Note/illustration
1.	 <p>DANGER! Before commencing any work inside the cabinet, please observe the safety information in section <i>DANGER - Make sure that the main power has been switched off!</i> on page 30.</p>	
2.	Reconnect the connector to the fan.	
3.	Refit the fan by placing the attachments in the back of the fan housing in the grooves.	 <p>xx0500002015</p> <ul style="list-style-type: none"> • A: fan • B: attachments • C: grooves
4.	Refit the cover and the attachment screws.	
5.	Refit the moist dust filter magazine. (Option)	How to refit the moist dust filter magazine is detailed in section <i>Replacement of moist dust filter</i> on page 171.

4 Repair activities, controller IRC5

4.25. Replacement of transformer unit

4.25. Replacement of transformer unit

Location

The illustration below shows the location of the transformer unit in the Single Cabinet Controller.

In the Dual Cabinet Controller the transformer is located in the back of the Drive Module.

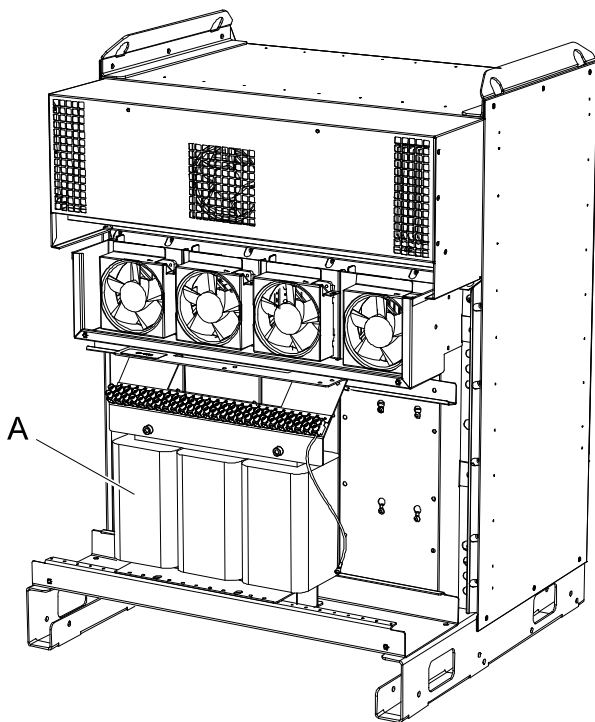

xx0500002028

A	Transformer
---	-------------

Required equipment



Equipment	Note
Transformer unit	13kVA, 6kVA, 4.5kVA, 1.2kVA See Miscellaneous parts on page 306 .
Standard toolkit	The contents are defined in section Standard toolkit
Circuit diagram	See Circuit Diagram on page 319 .

© Copyright 2004-2010 ABB. All rights reserved.

Continues on next page

Removal

The following procedures details how to remove the transformer unit.

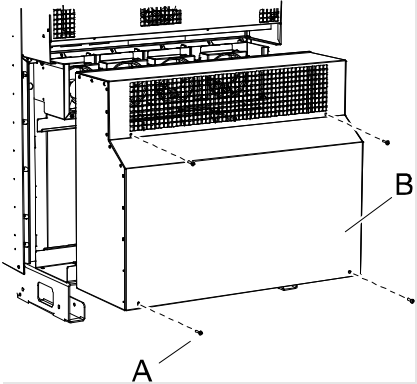
	Action	Note/illustration
1.	 <p>DANGER! Before commencing any work inside the cabinet, please observe the safety information in section <i>DANGER - Make sure that the main power has been switched off!</i> on page 30.</p>	
2.	 <p>WARNING! The transformer weighs between 15 and 40 kg, use a hoist and lifting slings.</p>	
3.	Remove the moist dust filter magazine. (Option)	How to remove the moist dust filter magazine is detailed in section <i>Replacement of moist dust filter</i> on page 171.
4.	Loosen the attachment screws.	 <p>xx0500002027</p> <ul style="list-style-type: none"> • A: attachment screw (4pcs) • B: cover
5.	Remove the cover.	
6.	Disconnect the two grounding wires (gnye, blue).	
7.	Disconnect the mains power supply wires.	<p>NOTE! Make a note of the terminal to which each of the wires are connected. This will facilitate reconnection to the same terminal.</p>

4 Repair activities, controller IRC5

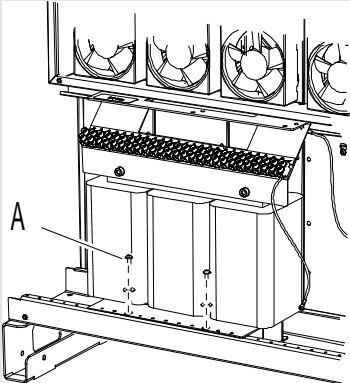
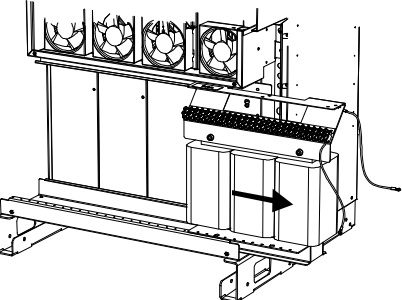

4.25. Replacement of transformer unit

Continued

	Action	Note/illustration
	8. Remove the two transformer attachment screws.	 <p>xx0500002032</p> <ul style="list-style-type: none"> A: attachment screw (2pcs)
	9. Push the transformer unit side ways and lift it out with lifting slings and a hoist.	 <p>xx0500002033</p>

Refitting

The following procedure details how to refit the transformer unit.

	Action	Note/illustration
1.	 <p>DANGER! Before commencing any work inside the cabinet, please observe the safety information in section <i>DANGER - Make sure that the main power has been switched off!</i> on page 30.</p>	
2.	 <p>WARNING! The transformer weighs between 15 and 40 kg, use a hoist and lifting slings.</p>	
3.	Fit the new transformer in place with a hoist and lifting slings.	
4.	Refit the attachment screws.	
5.	Reconnect the mains power supply wires and grounding wires.	

© Copyright 2004-2010 ABB. All rights reserved.

Continues on next page

Continued

	Action	Note/illustration
6.	Refit the cover.	
7.	Refit the moist dust filter magazine. (Option)	How to refit the moist dust filter magazine is detailed in section Replacement of moist dust filter on page 171 .

4 Repair activities, controller IRC5

4.26. Replacement of brake resistor bleeder

4.26. Replacement of brake resistor bleeder

Location

The illustration below shows the location of the brake resistor bleeder (behind the cover) in the Single Cabinet Controller.

In the Dual Cabinet Controller the brake resistor bleeder is located in the Drive Module.

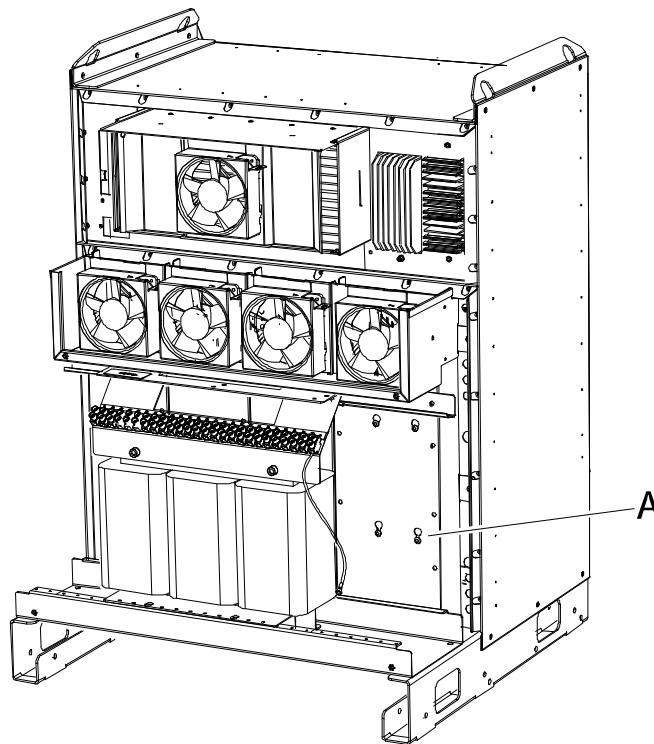

xx0500002022

A Brake resistor bleeder (behind plate, not visible).

Required equipment

Equipment	Note
Brake resistor bleeder	See Miscellaneous parts on page 306 .
Standard toolkit	The contents are defined in section Standard toolkit
Other tools and procedures may be required. See references to these procedures in the step-by-step instructions below.	These procedures include references to the tools required.
Circuit diagram	See Circuit Diagram on page 319 .

© Copyright 2004-2010 ABB. All rights reserved.

Continues on next page

Removal, Single Cabinet Controller

The following procedure details how remove the brake resistor bleeder in the Single Cabinet Controller.

	Action	Note/illustration
1.	 <p>DANGER! Before commencing any work inside the cabinet, please observe the safety information in section <i>DANGER - Make sure that the main power has been switched off!</i> on page 30.</p>	
2.	Remove the moist dust filter magazine. (Option)	How to remove the moist dust filter magazine is detailed in section <i>Replacement of moist dust filter</i> on page 171.
3.	Remove the covers in the back of the controller.	<p>xx0700000418</p> <ul style="list-style-type: none"> • A: top cover • B: transformer cover • C: attachment screw (8 pcs)

4 Repair activities, controller IRC5

4.26. Replacement of brake resistor bleeder

Continued

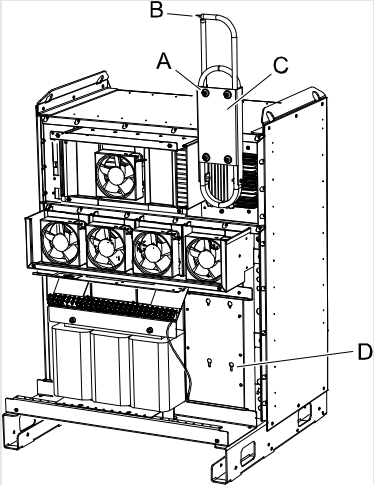
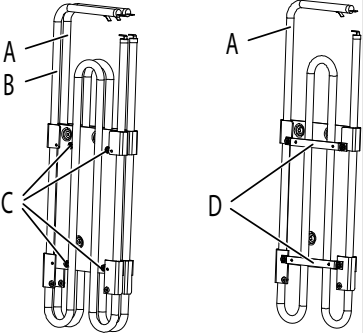
	Action	Note/illustration
4.	Disconnect the two connectors from the bleeder.	 <p>xx0500002020</p> <ul style="list-style-type: none"> • A: attachment screw (4 pcs) • B: connectors • C: brake resistor bleeder • D: bleeder attachment screw (4 pcs)
5.	Loosen the <i>attachment screws</i> for the brake resistor bleeder.	
6.	Lift the <i>bleeder</i> slightly and push it in to release the attachments.	
7.	Lift the <i>bleeder</i> straight up.	
8.	<p>If the IRC5 controller uses an Additional Rectifier Unit, an extra ARU bleeder is mounted on the MDU bleeder.</p> <p>Remove the attachment screws and remove the ARU bleeder from the MDU bleeder.</p> <p>Remove the mounting brackets for the ARU bleeder.</p>	 <p>xx1000000030</p> <ul style="list-style-type: none"> • A: MDU bleeder • B: ARU bleeder • C: Attachment screws • D: Mounting brackets for ARU bleeder

© Copyright 2004-2010 ABB. All rights reserved.

Continues on next page

Removal, Dual Cabinet Controller

The following procedure details how to remove the brake resistor bleeder in the Dual Cabinet Controller, Drive Module.

	Action	Note/Illustration
1.	 DANGER! Before any work inside the cabinet, please observe the safety information in section DANGER - Make sure that the main power has been switched off! on page 30.	
2.	Remove the moist dust filter magazine. (Option)	How to remove the moist dust filter magazine is detailed in section Replacement of moist dust filter on page 171.
3.	Remove the covers in the back of the Control Module and Drive Module.	
4.	Remove cable protectors on the Drive Module gables. Leave the lower screws in place.	
5.	Loosen the screws that fastens the Control Module to the Drive Module.	6 pcs M8 screws
6.	Lift carefully the Control Module in the front edge and pull the Control Module 10 cm so it rests on the upper front edge of the Drive Module.	
7.	Disconnect the two connectors from the bleeder.	
8.	Loosen the attachment screws for the bleeder.	
9.	Lift the bleeder slightly and push it in to release the attachments.	
10.	Lift the bleeder straight up.	
11.	If the IRC5 controller uses an Additional Rectifier Unit, an extra ARU bleeder is mounted on the MDU bleeder. Remove the ARU bleeder from the MDU bleeder and remove the mounting brackets for the ARU bleeder.	

4 Repair activities, controller IRC5

4.26. Replacement of brake resistor bleeder

Continued

Refitting, Single Cabinet Controller

The following procedure details how to refit the brake resistor bleeder in the Single Cabinet Controller.

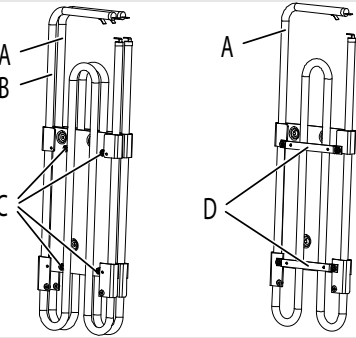
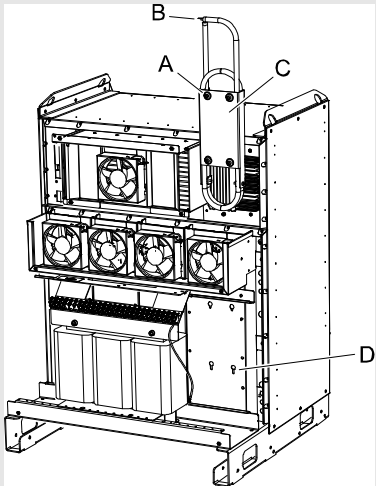
	Action	Note/illustration
1.	 <p>DANGER! Before commencing any work inside the cabinet, please observe the safety information in section <i>DANGER - Make sure that the main power has been switched off!</i> on page 30.</p>	
2.	<p>If the IRC5 controller uses an Additional Rectifier Unit, an extra ARU bleeder is required.</p> <p>Attach the mounting brackets for ARU bleeder on the MDU bleeder.</p> <p>Attach the ARU bleeder to the MDU bleeder.</p>	 <p>xx100000030</p> <ul style="list-style-type: none"> • A: MDU bleeder • B: ARU bleeder • C: Attachment screws • D: Mounting brackets for ARU bleeder
3.	<p>Slide the new bleeder in to place and fit the attachment screws in the key hole attachments.</p>	 <p>xx0500002020</p> <ul style="list-style-type: none"> • A: attachment screw (4 pcs) • B: connectors • C: brake resistor bleeder • D: bleeder attachment screw (4 pcs)

© Copyright 2004-2010 ABB. All rights reserved.

Continues on next page

Continued

	Action	Note/illustration
4.	Tightening the four <i>attachment screws</i> .	
5.	Reconnect the <i>connectors</i> .	
6.	Refit the covers.	
7.	Refit the moist dust filter magazine. (Option)	How to refit the moist dust filter magazine is detailed in section Replacement of moist dust filter on page 171 .

Refitting, Dual Cabinet Controller

The following procedure details how to refit the brake resistor bleeder in to the Dual Cabinet Controller, Drive Module.

	Action	Note/Illustration
1.	 <p>DANGER! Before any work inside the cabinet, please observe the safety information in section DANGER - Make sure that the main power has been switched off! on page 30.</p>	
2.	If the IRC5 controller uses an Additional Rectifier Unit, an extra ARU bleeder is required. Attach the mounting brackets for ARU bleeder on the MDU bleeder and then attach the ARU bleeder.	
3.	Slide the new bleeder in to place and fit the attachment screws in the key hole attachments.	
4.	Tightening the four attachment screws.	
5.	Reconnect the connectors.	
6.	Lift carefully the Control Module in the front edge and push the Control Module 10 cm to it's mounting position on top of the Drive Module.	
7.	Refit the screws that fastens the Control Module to the Drive Module.	6 pcs M8 screws
8.	Refit the cable protectors on the Drive Module gables.	
9.	Refit the covers.	
10.	Refit the moist dust filter magazine. (Option)	How to refit the moist dust filter magazine is detailed in section Replacement of moist dust filter on page 171 .

4 Repair activities, controller IRC5

4.27. Replacement of Process Interface Board

4.27. Replacement of Process Interface Board

About the Process Interface Board

A Process Interface Board is mounted in the controller cabinet if option *DispensePac support* is used.

Location

The illustration below shows the location of the Process Interface Board.

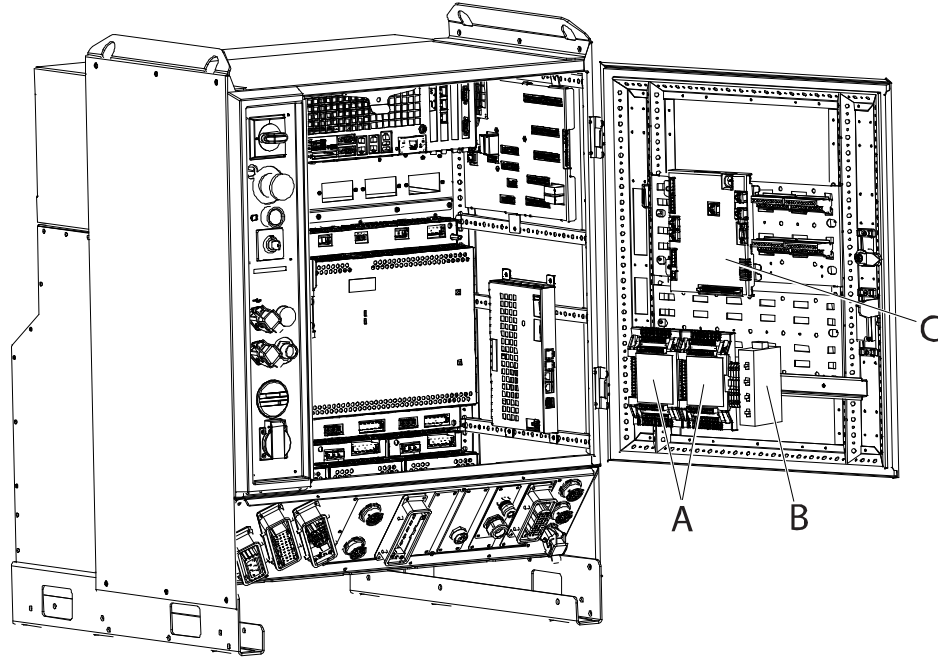

xx0600002681

C Process Interface Board



Required equipment

Equipment	Note
Torx screw driver, size T25	Used for the Process Interface Board.



© Copyright 2004-2010 ABB. All rights reserved.

Continues on next page

Removing the Process Interface Board

Action	
1.	 <p>DANGER! Before commencing any work inside the cabinet, please observe the safety information in section DANGER - Make sure that the main power has been switched off! on page 30.</p>
2.	 <p>esd WARNING! The unit is sensitive to ESD. Before handling the unit please read the safety information in the section WARNING - The unit is sensitive to ESD! on page 31</p>
3.	Disconnect all connectors from the Process Interface Board.
4.	Remove the 4 attachment screws and remove the board.

Refitting the Process Interface Board

Action	
1.	 <p>DANGER! Before commencing any work inside the cabinet, please observe the safety information in section DANGER - Make sure that the main power has been switched off! on page 30.</p>
2.	 <p>esd WARNING! The unit is sensitive to ESD. Before handling the unit please read the safety information in the section WARNING - The unit is sensitive to ESD! on page 31</p>
3.	Fit the Process Interface Board on the attachment plate and fasten it with the 4 attachment screws.
4.	Connect all connectors to the Process Interface Board.

4 Repair activities, controller IRC5

4.28. Replacement of Ethernet switch

4.28. Replacement of Ethernet switch

About the Ethernet switch

An Ethernet switch is mounted in the controller cabinet if option *DispensePac support* is used.

Location

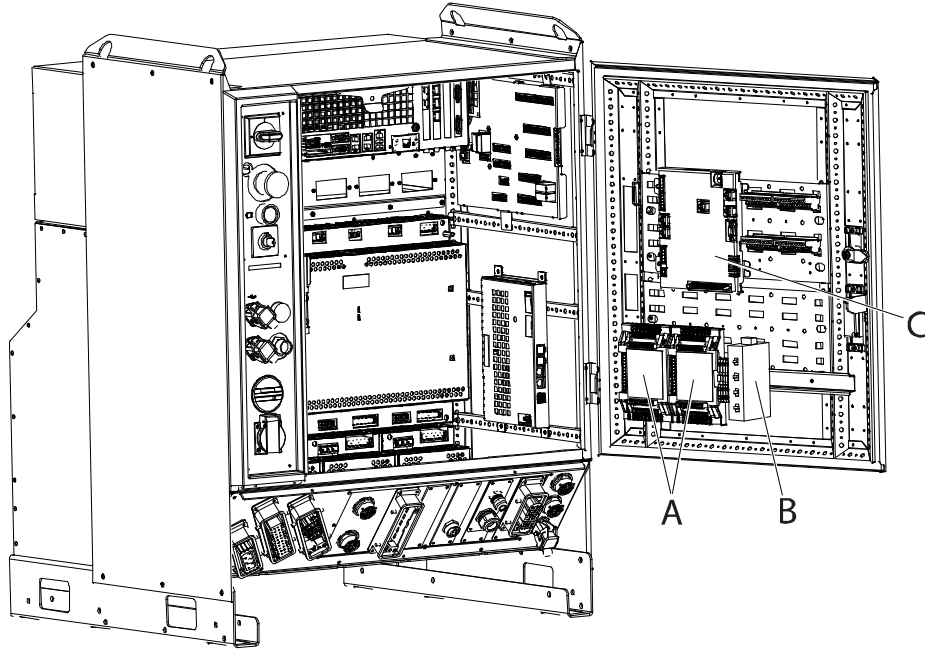

The illustration below shows the location of the Ethernet switch.



xx0600002681

B Ethernet switch



Removing the switch

	Action
1.	 DANGER! Before commencing any work inside the cabinet, please observe the safety information in section DANGER - Make sure that the main power has been switched off! on page 30 .
2.	 esd WARNING! The unit is sensitive to ESD. Before handling the unit please read the safety information in the section WARNING - The unit is sensitive to ESD! on page 31
3.	Disconnect all connectors from the switch.
4.	Pull the spring lock to remove the switch.

© Copyright 2004-2010 ABB. All rights reserved.

Continues on next page

Refitting the switch

	Action
1.	 DANGER! Before commencing any work inside the cabinet, please observe the safety information in section <i>DANGER - Make sure that the main power has been switched off! on page 30.</i>
2.	 esd WARNING! The unit is sensitive to ESD. Before handling the unit please read the safety information in the section <i>WARNING - The unit is sensitive to ESD! on page 31</i>
3.	Pull the spring lock and attach the switch to the mounting bar.
4.	Connect all connectors to the switch.

4 Repair activities, controller IRC5

4.29.1. Replacement of control power supply

4.29 Replacement of power supply

4.29.1. Replacement of control power supply

Location

The control power supply is located on the left hand side as shown in the illustration below. For the Dual Cabinet Controller the control power supply is located in the Control Module with the same placement.

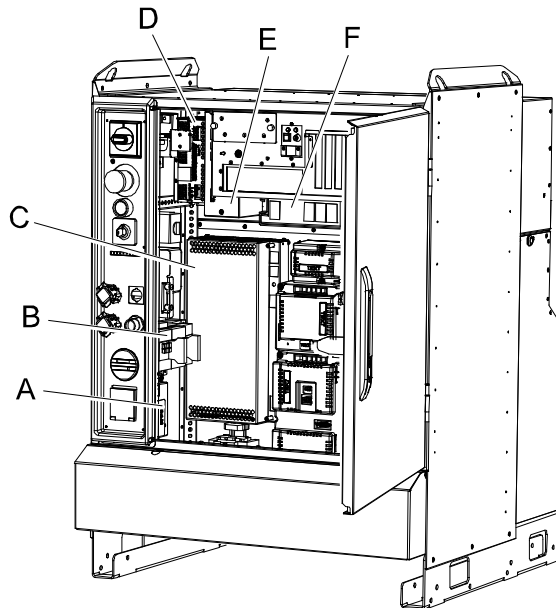

xx0400000815

A	Contactors interface board
B	Contactors
C	Drive unit power supply
D	Customer I/O power supply
E	Control power supply
F	Backup energy bank

Required equipment

Equipment	Spare part no.	Art. no.	Note
Control Power Supply	3HAC12928-1		DSQC 604
Standard toolkit			The contents are defined in section Standard toolkit!
Other tools and procedures may be required. See references to these procedures in the step-by-step instructions below.			These procedures include references to the tools required.
Circuit Diagram		3HAC024480-004	Complete control system

Continues on next page

Removal

The procedures below details how to remove the control power supply.

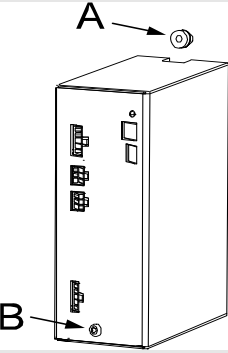
	Action	Note/Illustration
1.	 <p>DANGER! Before commencing any work inside the cabinet, please observe the safety information in section <i>DANGER - Make sure that the main power has been switched off!</i> on page 30.</p>	
2.	Disconnect the connectors X1 - X4 on the control power supply.	
3.	Loosen the attachment screw and pull the power supply down to release it from the cap nut.	 <p>xx04000000976</p> <ul style="list-style-type: none"> • A: cap nut • B: attachment screw
4.	Remove the power supply unit.	

4 Repair activities, controller IRC5

4.29.1. Replacement of control power supply

Continued

Refitting

The procedures below details how to refit the control power supply.

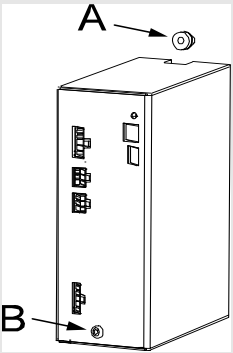
	Action	Note/Illustration
1.	 <p>DANGER! Before commencing any work inside the cabinet, please observe the safety information in section <i>DANGER - Make sure that the main power has been switched off!</i> on page 30.</p>	
2.	<p>Refit the new power supply unit by pushing it upward to fit the cap nut. Refit the control power supply by pull it down to fit the cap nut.</p>	 <p>xx04000000976</p> <ul style="list-style-type: none"> A: cap nut
3.	Lock the unit in place by tighten the attachment screw.	
4.	Reconnect the connectors X1 - X4.	
5.	Refit the front with the Panel Board Unit.	

4.29.2. Replacement of power distribution board

Location

The power distribution board is located on the left side as shown in the illustration below.

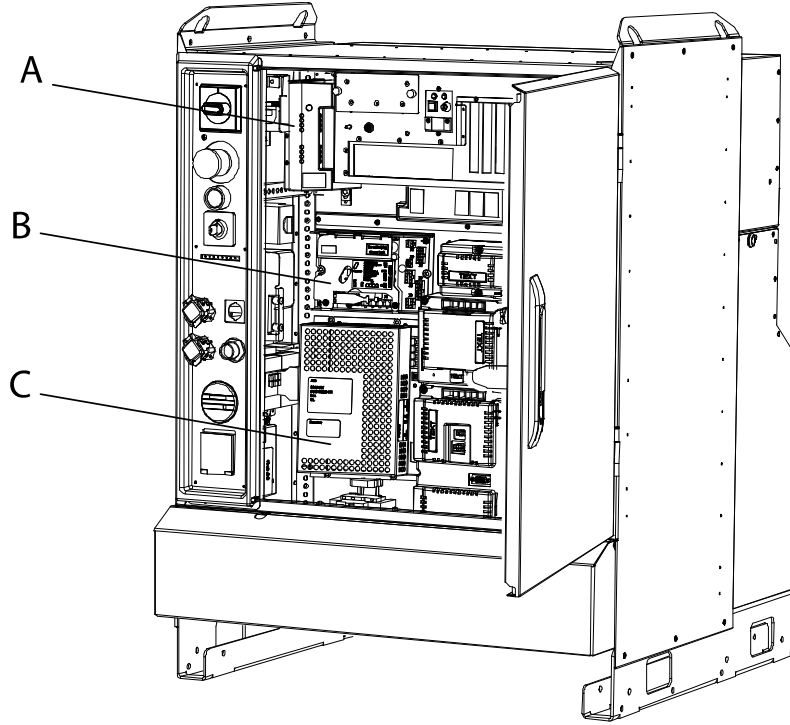

xx0700000139

A	Customer I/O power supply
B	Power distribution board
C	System power supply



CAUTION!

Hot surface on top of the power distribution board unit.

Risk of burns. Be careful when removing the unit.

Do not route or place cables on top of the power distribution board.

Required equipment

Equipment	Spare part no.	Art. no.	Note
Power distribution board	3HAC026254-001		DSQC 662
Standard toolkit			The contents are defined in section Standard toolkit.
Other tools and procedures may be required. See references to these procedures in the step-by-step instructions below.			
Circuit diagram		3HAC024480-004	

Continues on next page



4 Repair activities, controller IRC5

4.29.2. Replacement of power distribution board

Continued

Removal

The procedure below details how to remove the power distribution board.

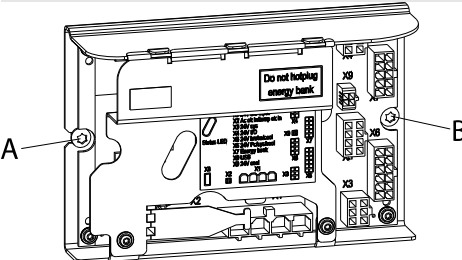

	Action	Note/Illustration
1.	 <p>DANGER! Before commencing any work inside the cabinet, please observe the safety information in section <i>DANGER - Make sure that the main power has been switched off!</i> on page 30.</p>	
2.	 <p>CAUTION! Hot surface on top of the power distribution board unit. Risk of burns. Be careful when removing the unit.</p>	
3.	Disconnect the connectors X1 - X9 on the power distribution board.	
4.	Loosen the left attachment screw, remove the right attachment screw and pull the power distribution board rightward to release it from the left screw head.	 <p>xx070000122</p> <ul style="list-style-type: none"> • A: left attachment screw • B: right attachment screw
5.	Remove the power distribution board.	

© Copyright 2004-2010 ABB. All rights reserved.

Continues on next page

Refitting

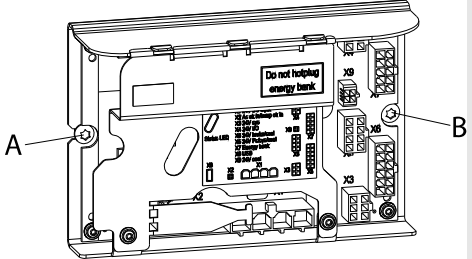
The procedure below details how to refit the power distribution board.

	Action	Note/Illustration
1.	 <p>DANGER! Before commencing any work inside the cabinet, please observe the safety information in section <i>DANGER - Make sure that the main power has been switched off!</i> on page 30.</p>	
2.	<p>Refit the new power distribution board by pushing it leftward to fit the left screw head. Refit the right screw.</p>	 <p style="text-align: center;">xx070000122</p> <ul style="list-style-type: none"> • A: left attachment screw • B: right attachment screw
3.	<p>Lock the unit in place by tighten the attachment screws.</p>	
4.	 <p>CAUTION! Hot surface on top of the power distribution board unit. Do not route or place cables on top of the power distribution board.</p>	

4 Repair activities, controller IRC5

4.29.3. Replacement of customer I/O power supply, IRC5

4.29.3. Replacement of customer I/O power supply, IRC5

Location

The customer I/O power supply is located as shown in the illustration below. For the Dual Cabinet Controller the customer I/O power supply is located in the Control Module with the same placement.

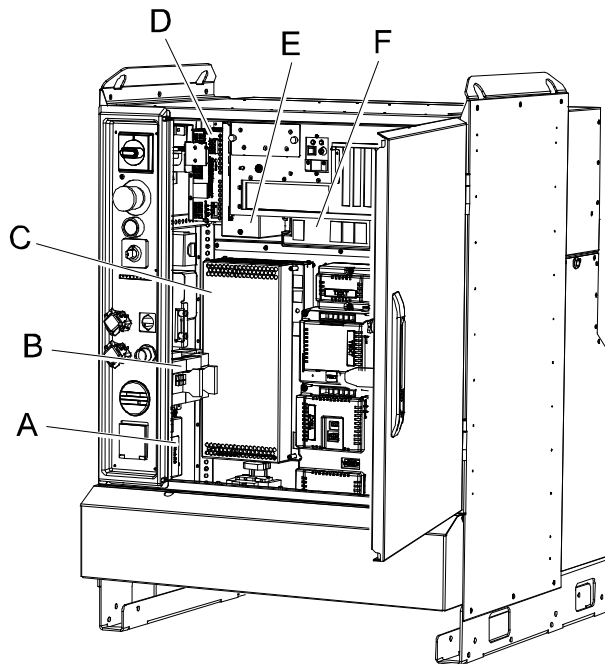

xx0500001951

A	Contactor interface board
B	Contactors
C	Drive system power supply
D	Customer I/O power supply
E	Control power supply
F	Backup energy bank

Required equipment

Equipment	Spare part no.	Art. no.	Note
Customer I/O Power Supply	3HAC12934-1		DSQC 608
Standard toolkit			The contents are defined in section Standard toolkit!
Other tools and procedures may be required. See references to these procedures in the step-by-step instructions below.			These procedures include references to the tools required.
Circuit Diagram		3HAC024480-004 3HAC026871-005	Complete control system

Continues on next page

Removal

The procedure below details how to remove the customer I/O power supply.

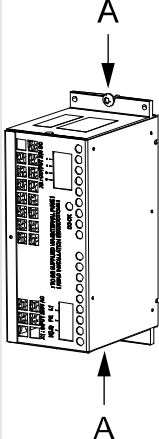
	Action	Note/Illustration
1.	 <p>DANGER! Before commencing any work inside the cabinet, please observe the safety information in section <i>DANGER - Make sure that the main power has been switched off!</i> on page 30.</p>	
2.	Remove the Flange disconnect unit. (option)	Detailed in section <i>Replacement of Flange disconnect</i> on page 183
3.	Disconnect all connectors.	NOTE! Make a note of any connections.
4.	Remove the upper and lower attachment screws.	 <p>xx0400000908</p> <ul style="list-style-type: none"> A: attachment screw (2 pcs)
5.	Remove the power supply unit.	

4 Repair activities, controller IRC5

4.29.3. Replacement of customer I/O power supply, IRC5

Continued

Refitting

The procedure below details how to refit the customer I/O power supply.

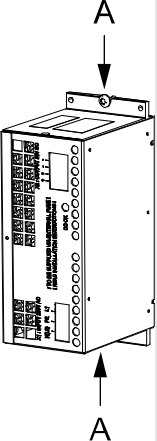
	Action	Note/Illustration
1.	 <p>DANGER! Before commencing any work inside the cabinet, please observe the safety information in section <i>DANGER - Make sure that the main power has been switched off!</i> on page 30.</p>	
2.	Refit the new power supply unit.	
3.	Refit the attachment screws.	 <p>xx0400000908</p> <ul style="list-style-type: none"> A: attachment screw (2pcs)
4.	Reconnect all connectors.	
5.	Refit the Flange disconnect unit (option).	Detailed in section <i>Replacement of Flange disconnect</i> on page 183

4.29.4. Replacement of customer I/O power supply

Location

The customer I/O power supply is located as shown in the figure below. For the Dual Cabinet Controller the customer I/O power supply is located in the Control Module with the same placement.

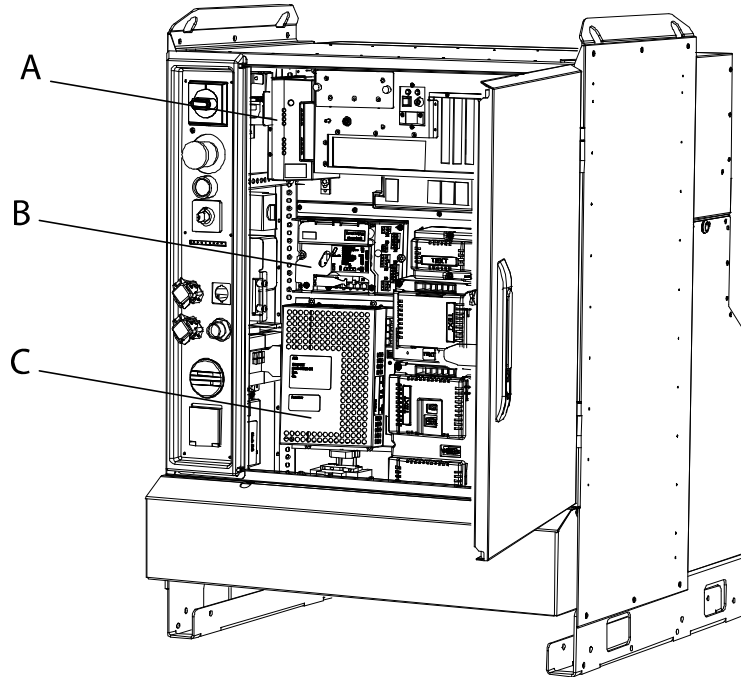

xx0700000139

A	Customer I/O power supply
B	Power distribution board
C	System power supply



CAUTION!

If there are two or more Customer I/O power supply units mounted in a row and too close to each other, there will be a heating problem and the units can be damaged.

To avoid damaging the Customer I/O power supply units, the units must be separated with 3 pcs of exterior support.

Required equipment

Equipment	Spare part no.	Art. no.	Note
Customer I/O power supply	3HAC14178-1		DSQC 609
Standard toolkit			The contents are defined in section Standard toolkit.
Other tools and procedures may be required. See references to these procedures in the step-by-step instructions below.			These procedures include references to the tools required.
Circuit diagram.		3HAC024480-004	

Continues on next page

4 Repair activities, controller IRC5

4.29.4. Replacement of customer I/O power supply

Continued

Removal

The procedure below details how to remove the customer I/O power supply.

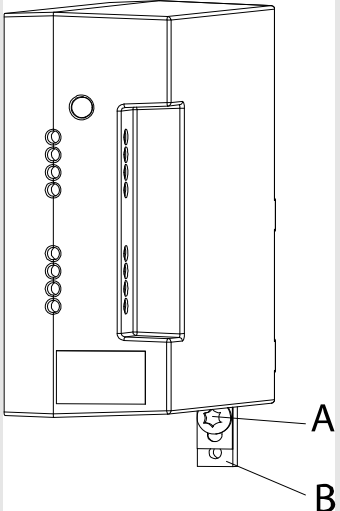
	Action	Note/Illustration
1.	 <p>DANGER! Before commencing any work inside the cabinet, please observe the safety information in section DANGER - Make sure that the main power has been switched off! on page 30.</p>	
2.	Remove the Flange disconnect unit (option).	Detailed in section Replacement of Flange disconnect on page 183
3.	Loosen the terminal screws for each connected wire. Remove wires from the terminals.	
4.	Loosen the DIN-lock fixing screw.	 <p>xx070000124</p> <ul style="list-style-type: none"> • A: DIN-lock fixing screw • B: DIN-lock lever
5.	Pull the DIN-lock lever downwards to release the power supply unit.	
6.	Remove the power supply unit.	

© Copyright 2004-2010 ABB. All rights reserved.

Continues on next page

Refitting

The procedure below details how to refit the customer I/O power supply.

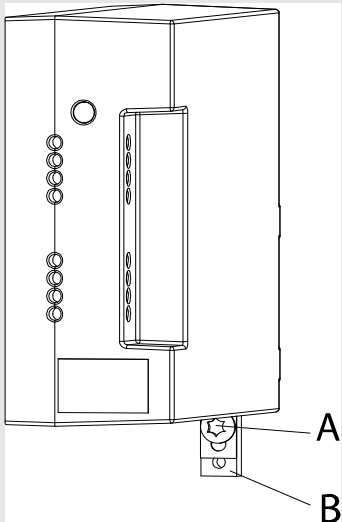
	Action	Note/Illustration
1.	 <p>DANGER! Before commencing any work inside the cabinet, please observe the safety information in section <i>DANGER - Make sure that the main power has been switched off! on page 30.</i></p>	
2.	Refit the new power supply unit on the DIN-rail.	
3.	Fasten the DIN-lock fixing screw.	 <p style="text-align: right;">xx0700000124</p> <ul style="list-style-type: none"> • A: DIN-lock fixing screw • B: DIN-lock lever
4.	Refit all wires in the screw terminals.	
5.	Fasten the screw terminal screws with correct torque.	
6.	Refit the Flange disconnect unit (option).	Detailed in section <i>Replacement of Flange disconnect on page 183.</i>

4 Repair activities, controller IRC5

4.29.5. Replacement of drive system power supply

4.29.5. Replacement of drive system power supply

Location

The illustration below shows the location of the drive system power supply in a Single Cabinet Controller.

In the Dual Cabinet Controller the drive system power supply is located in the Drive Module.

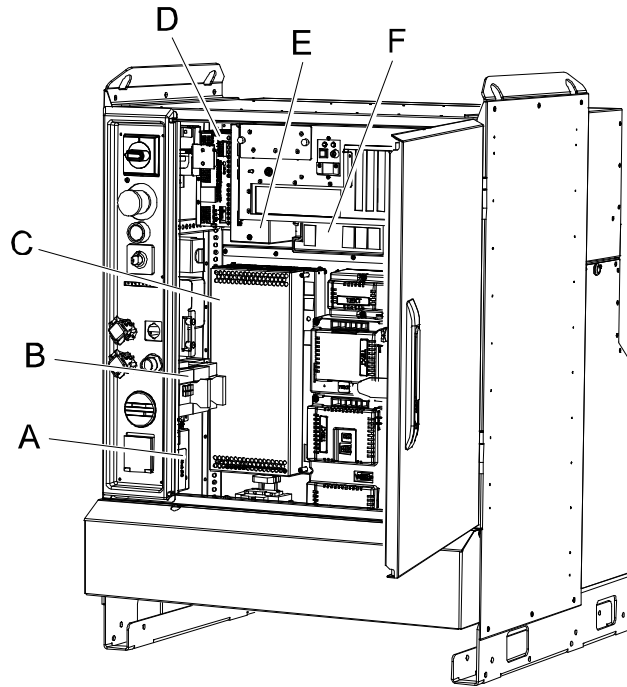

xx0500001951

A	Contactor interface board
B	Contactor
C	Drive system power supply
D	Customer I/O power supply
E	Control power supply
F	Backup energy bank

Required equipment

Equipment	Spare part no.	Art. no.	Note
Drive system power supply	3HAC026289-001		DSQC 626A
Drive system power supply	3HAC020466-001		DSQC 627
Standard toolkit			The contents are defined in section Standard toolkit!
Other tools and procedures may be required. See references to these procedures in the step-by-step instructions below.			These procedures include references to the tools required.
Circuit Diagram		3HAC024480-004	Complete control system

Continues on next page

Removal

The procedure below details how to remove the drive system power supply.

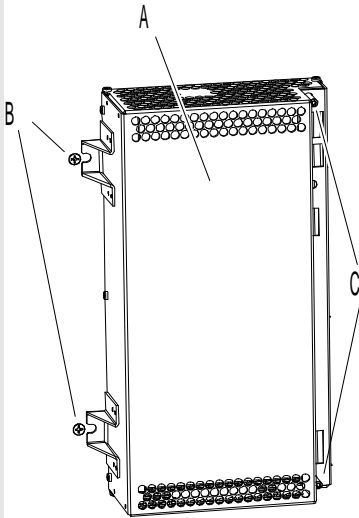
	Action	Note/Illustration
1.	 <p>DANGER! Before commencing any work inside the cabinet, please observe the safety information in section <i>DANGER - Make sure that the main power has been switched off!</i> on page 30.</p>	
2.	Disconnect all connectors from the unit.	 <p style="font-size: small;">xx0500001842</p> <ul style="list-style-type: none"> • A: drive system power supply • B: cup nut (2 pcs) • C: attachment screw (2 pcs)
3.	Loosen the attachment screws.	
4.	Pull the power supply unit to the right to release it from the <i>cap nuts</i> , and remove it.	

4 Repair activities, controller IRC5

4.29.5. Replacement of drive system power supply

Continued

Refitting

The procedure below details how to refit the drive system power supply.

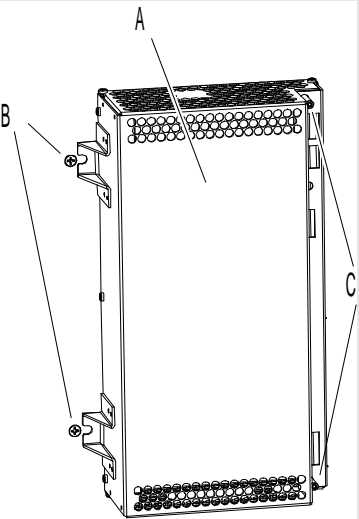
Action	Note/Illustration
<p>1.</p>  <p>Danger</p> <p>DANGER!</p> <p>Before any repair work, please observe the safety information in section <i>DANGER - Make sure that the main power has been switched off!</i></p>	
<p>2. Refit the power supply by sliding the recesses in beneath the cap nuts, and push it to the left.</p>	 <p>xx0500001842</p> <ul style="list-style-type: none"> • A: drive system power supply • B: cup nut (2 pcs) • C: attachment screw (2 pcs)
<p>3. Tighten the <i>attachment screws</i>.</p>	
<p>4. Reconnect all connectors to the unit .</p>	

© Copyright 2004-2010 ABB. All rights reserved.

4.29.6. Replacement of system power supply

Location

The illustration below shows the location of the system power supply in the Single Cabinet Controller.

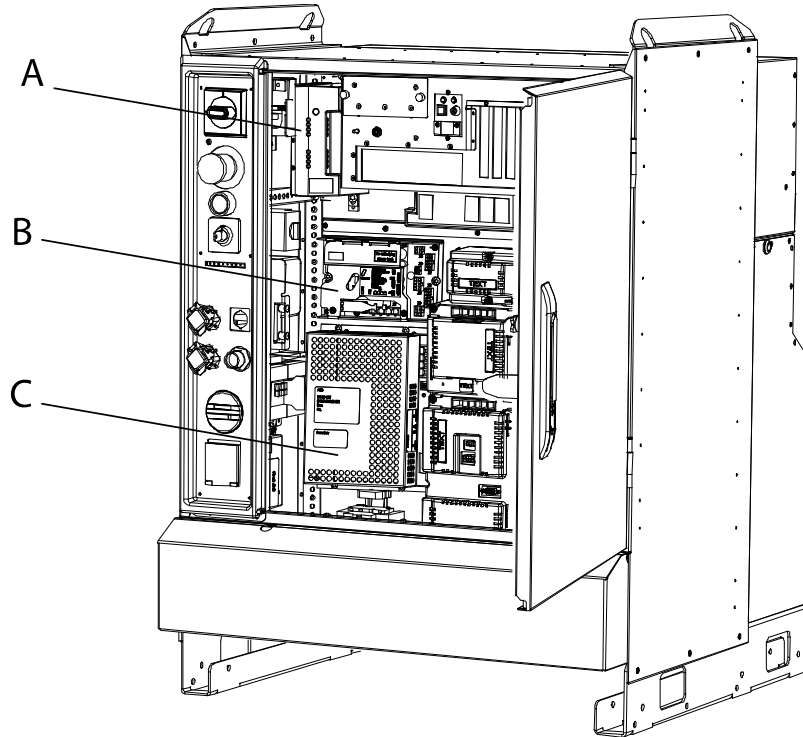

xx070000139

A	Customer I/O power supply
B	Power distribution board
C	System power supply

Required equipment

Equipment	Spare part no.	Art. no.	Note
System power supply	3HAC026253-001		DSQC 661
Standard toolkit			The contents are defined in section Standard toolkit.
Other tools and procedures may be required. See references to these procedures in the step-by-step instructions below.			
Circuit diagram		3HAC024480-004	

Continues on next page

4 Repair activities, controller IRC5

4.29.6. Replacement of system power supply

Continued

Removal

The procedure below details how to remove the system power supply.

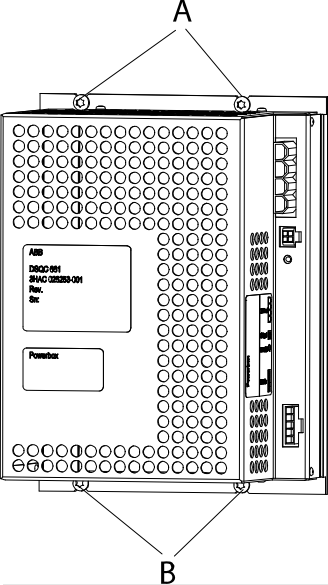
	Action	Note/Illustration
1.	 <p>DANGER! Before commencing any work inside the cabinet, please observe the safety information in section <i>DANGER - Make sure that the main power has been switched off!</i> on page 30.</p>	
2.	Disconnect all connectors from the unit.	
3.	Loosen the two lower attachment screws.	 <p>xx0700000125</p> <ul style="list-style-type: none"> • A: upper attachment screws • B: lower attachment screws
4.	Remove the two upper attachment screws.	
5.	Pull the power supply unit outwards and then upwards to release it from the lower screw heads, and remove it.	

© Copyright 2004-2010 ABB. All rights reserved.

Continues on next page

Refitting

The procedure below details how to refit the system power supply.

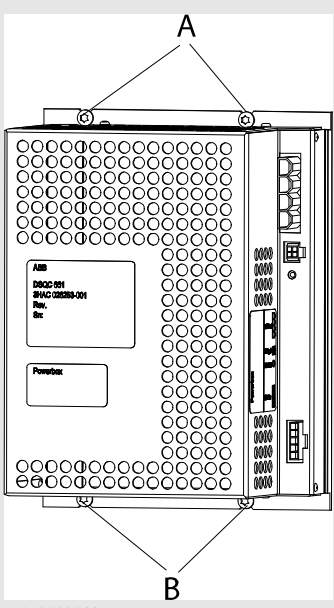
	Action	Note/Illustration
1.	 <p>DANGER! Before commencing any work inside the cabinet, please observe the safety information in section <i>DANGER - Make sure that the main power has been switched off!</i> on page 30.</p>	
2.	<p>Refit the power supply by sliding the recesses in beneath the lower screw heads, and push it inwards and the downwards.</p>	 <p style="text-align: center;">xx0700000125</p> <ul style="list-style-type: none"> • A: upper attachment screws • B: lower attachment screws
3.	<p>Refit the two upper attachment screws.</p>	
4.	<p>Tighten the attachment screws (4 pcs).</p>	
5.	<p>Reconnect all connectors to the unit.</p>	

4 Repair activities, controller IRC5

4.29.6. Replacement of system power supply

5 Decommissioning

5.1. Introduction

Introduction

This section contains information to consider when taking a product, robot or controller, out of operation.

It deals with how to handle potentially dangerous components and potentially hazardous materials.

General

All used grease/oils and dead batteries **must** be disposed of in accordance with the current legislation of the country in which the robot and the control unit are installed.

If the robot or the control unit is partially or completely disposed of, the various parts **must** be grouped together according to their nature (that is, all iron together and all plastic together), and disposed of accordingly. These parts **must** also be disposed of in accordance with the current legislation of the country in which the robot and control unit are installed.

5 Decommissioning

5.2. Environmental information

5.2. Environmental information

Hazardous material

The table specifies some of the materials in the controller cabinet and their respective use throughout the product.

Dispose of the components properly to prevent health or environmental hazards.

Material	Example application
Batteries, Lithium	Main computer
Copper	Cables
Steel	Cabinet structure, plates, screws, etc.
Plastic/rubber (PVC)	Cables, connectors, etc.
Aluminium	Heat sinks on power supplies and drive units
Lead	Electronics
Brominated flame retardants	Electronics

6 Reference information, IRC5

6.1. Introduction

General

This chapter includes general information, complementing the more specific information in the different procedures in the manual.

6 Reference information, IRC5

6.2. Applicable safety standards

6.2. Applicable safety standards

Standards, EN ISO

The manipulator system is designed in accordance with the requirements of:

Standard	Description
EN ISO 12100 -1	Safety of machinery - Basic concepts, general principles for design - Part 1: Basic terminology, methodology
EN ISO 12100 -2	Safety of machinery - Basic concepts, general principles for design - Part 2: Technical principles
EN ISO 13849-1	Safety of machinery, safety related parts of control systems - Part 1: General principles for design
EN ISO 13850	Safety of machinery - Emergency stop - Principles for design
EN ISO 10218-1 ¹	Robots for industrial environments - Safety requirements -Part 1 Robot
EN ISO 9787	Manipulating industrial robots, Coordinate systems and motion nomenclatures
EN ISO 9283	Manipulating industrial robots, Performance criteria and related test methods
EN ISO 14644-1 ²	Classification of air cleanliness
EN ISO 13732-1	Ergonomics of the thermal environment - Part 1
EN IEC 61000-6-4 (option 129-1)	EMC, Generic emission
EN IEC 61000-6-2	EMC, Generic immunity
EN IEC 60974-1 ³	Arc welding equipment - Part 1: Welding power sources
EN IEC 60974-10 ³	Arc welding equipment - Part 10: EMC requirements
EN IEC 60204-1	Safety of machinery - Electrical equipment of machines - Part 1 General requirements
IEC 60529	Degrees of protection provided by enclosures (IP code)

1. There is a deviation from paragraph 6.2 in that only worst case stop distances and stop times are documented.

2. Only robots with Protection Clean Room.

3. Only valid for arc welding robots. Replaces EN IEC 61000-6-4 for arc welding robots.

European standards

Standard	Description
EN 614-1	Safety of machinery - Ergonomic design principles - Part 1: Terminology and general principles
EN 574	Safety of machinery - Two-hand control devices - Functional aspects - Principles for design
EN 953	Safety of machinery - General requirements for the design and construction of fixed and movable guards

Continued

Other standards

Standard	Description
ANSI/RIA R15.06	Safety Requirements for Industrial Robots and Robot Systems
ANSI/UL 1740 (option 429-1)	Safety Standard for Robots and Robotic Equipment
CAN/CSA Z 434-03 (option 429-1)	Industrial Robots and Robot Systems - General Safety Requirements

6 Reference information, IRC5

6.3. Unit conversion

6.3. Unit conversion

Converter table

Use the table below to convert units used in this manual.

Quantity	Units		
Length	1 m	3.28 ft	39.37 in
Weight	1 kg	2.21 lb	
Pressure	1 bar	100 kPa	14.5 psi
Force	1 N	0.738 lbf	
Moment	1 Nm	0.738 lbf-tn	
Volume	1 L	0.264 US gal	

6.4. Screw joints

General

This section details how to tighten the various types of screw joints on the controller.

The instructions and torque values are valid for screw joints comprised of metallic materials and do *not* apply to soft or brittle materials.

Tightening torque

Before tightening any screw, note the following:

- Determine whether a standard tightening torque or special torque is to be applied. The standard torques are specified in the tables below. Any special torques are specified in the Repair, Maintenance or Installation procedure description. Any special torque specified overrides the standard value.
- Use the *correct tightening torque* for each type of screw joint.
- Only use *correctly calibrated* torque keys.
- Always *tighten the joint by hand*, and never use pneumatical tools.
- Use the *correct tightening technique*, i.e. *do not* jerk. Tighten the screw in a slow, flowing motion.
- Maximum allowed total deviation from the specified value is **10%**!

The table below specifies the recommended standard tightening torque for *oil-lubricated screws with slotted or cross-recess heads*.

Dimension	Tightening torque (Nm) Class 4.8, oil-lubricated
M2.5	0.25
M3	0.5
M4	1.2
M5	2.5
M6	5.0

6 Reference information, IRC5

6.5. Weight specifications

6.5. Weight specifications

Definition

In all repair and maintenance instructions, weights of the components handled are sometimes specified. All components exceeding 22 kg (50 lbs) are high-lighted in this way.

To avoid injury, ABB recommends the use of lifting equipment when handling components with a weight exceeding 22 kg.

Example

Below is an example of how a weight specification is presented:



CAUTION!

The transformer weighs 55 kg! All lifting equipment used must be sized accordingly!

6.6. Standard toolkit, IRC5

General

All service (repair, maintenance and installation) instructions contain lists of tools required to perform the specified activity. All special tools, i.e. all tools that are not considered standard as defined below, are listed in their instructions respectively.

This way, the tools required are the sum of the Standard Toolkit and any tools listed in the instruction.

Contents, standard toolkit, IRC5

Tool	Remark
Screw driver, Torx	Tx10
Screw driver, Torx	Tx20
Screw driver, Torx	Tx25
Ball tipped screw driver, Torx	Tx25
Screw driver, flat blade	4 mm
Screw driver, flat blade	8 mm
Screw driver, flat blade	12 mm
Screw driver	Phillips-1
Box spanner	8 mm

6.7. Lifting equipment and lifting instructions

General

Many repair and maintenance activities require different pieces of lifting equipment, which are specified in each procedure.

The use of each piece of lifting equipment is *not* detailed in the activity procedure, but in the instruction delivered with each piece of lifting equipment.

This implies that the instructions delivered with the lifting equipment should be stored for later reference.

7 Spare Parts

7.1 Controller parts

7.1.1. Single Cabinet Controller

General

The illustrations in this section show the locations of the parts in the IRC5 Single Cabinet Controller.

The spare parts for the Single and Dual Cabinet Controller are in general identical but the location of parts in the Dual Cabinet Controller are divided between the Control Module and the Drive Module.

Controller system parts (Drive System 04)

The illustration below shows the placement of the controller system parts in the recommended spare part list.

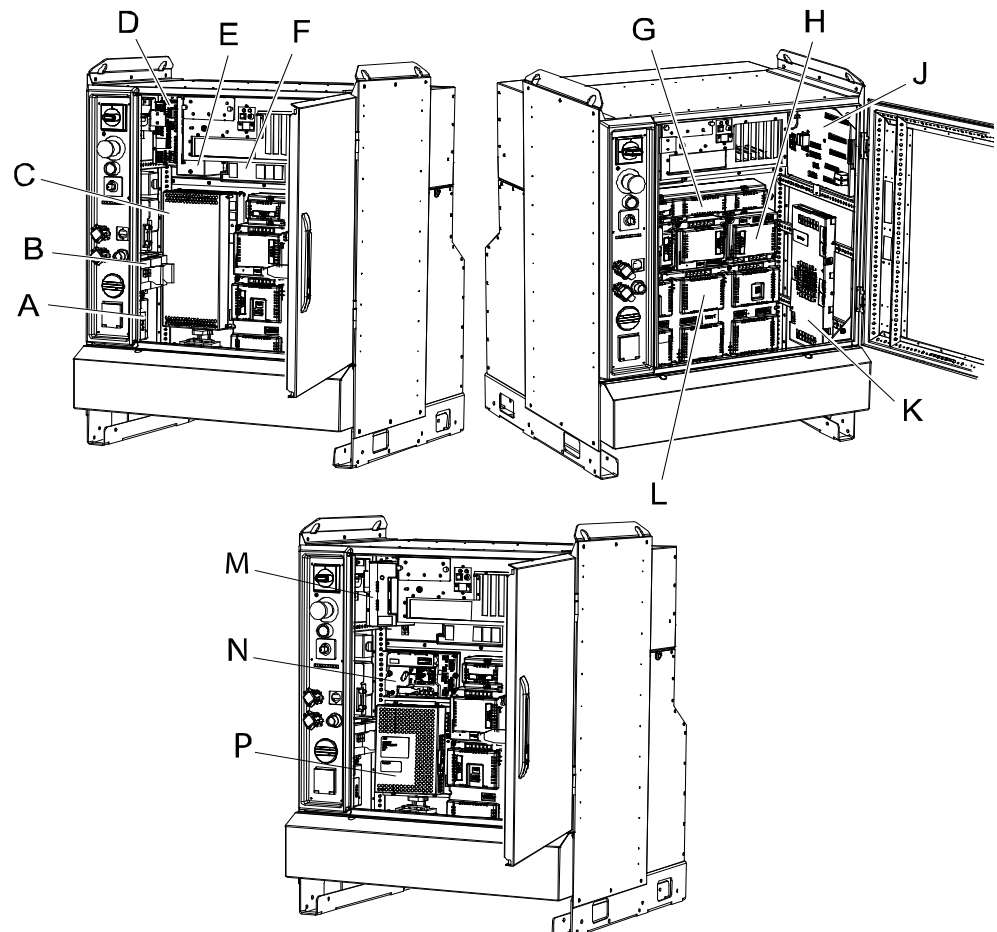

xx0600002680

	Spare part no.	Description	Note
L	3HAC025338-001	Main Servo Drive Unit, D6 3B 3A	DSQC 617
L	3HAC025338-002	Main Servo Drive Unit, D6 2E 2C 2B	DSQC 617

Continues on next page

7 Spare Parts

7.1.1. Single Cabinet Controller

Continued

	Spare part no.	Description	Note
L	3HAC025338-003	Main Servo Drive Unit, D4 3E 1C	DSQC 617
L	3HAC025338-004	Main Servo Drive Unit, D6 3T 3G	DSQC 617
L	3HAC025338-006	Main Servo Drive Unit, D6 3W 3V	DSQC 617
L	3HAC14550-1	Single servo drive unit	DSQC 619
L	3HAC14550-3	Single servo drive unit	DSQC 619
L	3HAC14550-4	Single servo drive unit	DSQC 619
H	3HAC14549-1	Rectifier	DSQC 618
H	3HAC14549-2	Rectifier	DSQC 618
G	3HAC14551-1	Capacitor Unit, C2	DSQC 620
G	3HAC14551-3	Capacitor Unit, C4	DSQC 620
J	3HAC024488-001	Panel board unit	DSQC 643
K	3HAC12815-1	Axis computer	DSQC 601
E	3HAC12928-1	Control power supply	DSQC 604
N	3HAC026254-001	Power distribution board	DSQC 662
C	3HAC026289-001	Drive system power supply standard.	DSQC 626A
C	3HAC020466-001	Drive system power supply ext.	DSQC 627
P	3HAC026253-001	System power supply	DSQC 661
D	3HAC12934-1	Customer I/O Power supply	DSQC 608
M	3HAC14178-1	Customer I/O power supply	DSQC 609
F	3HAC026585-001	Backup energy bank with adapter plate	DSQC 655
F	3HAC025562-001	Backup energy bank	DSQC 655
	3HAC030439-001	Remote Service box	DSQC 680
	3HAC13389-2	Contactora interface board	DSQC 611

Continued

Controller system parts (Drive System 09)

The illustration below shows the placement of the controller system parts in the recommended spare part list.

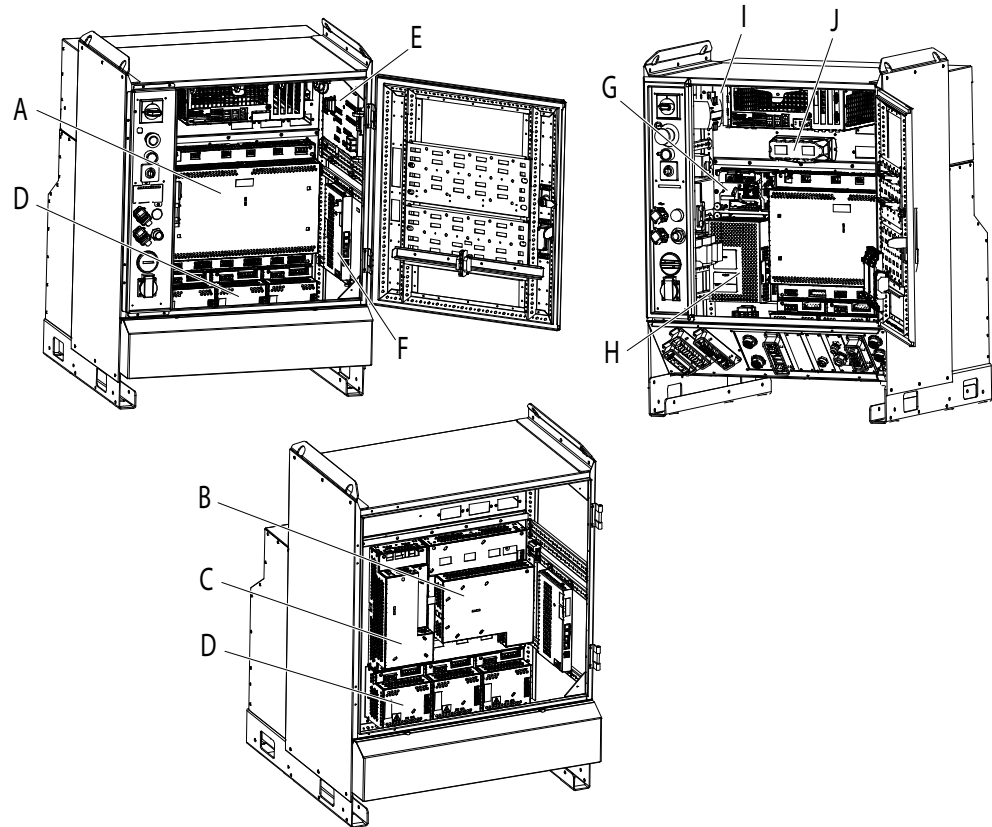

xx0900000046

	Spare part no.	Description	Note
A	3HAC029818-001	Main Drive Unit, MDU-790A	DSQC 663
B	3HAC035301-001	Main Drive Unit, MDU-430A	DSQC 406
C	3HAC035381-001	Additional Rectifier Unit, ARU-430A	DSQC 417
D	3HAC030923-001	Additional Drive Unit, ADU-790A	DSQC 664
E	3HAC024488-001	Panel board unit	DSQC 643
F	3HAC029159-1	Axis computer	DSQC 668
G	3HAC026254-001	Power distribution board	DSQC 662
H	3HAC026253-001	System power supply	DSQC 661
I	3HAC14178-1	Customer I/O power supply	DSQC 609
J	3HAC026585-001	Backup energy bank with adapter plate	DSQC 655
J	3HAC025562-001	Backup energy bank	DSQC 655
	3HAC030439-001	Remote Service box	DSQC 680
	3HAC13389-2	Contactorm interface board	DSQC 611

Continues on next page

7 Spare Parts

7.1.1. Single Cabinet Controller

Continued

I/O System parts

The illustration below shows the placement of the I/O system parts in the recommended spare part list.

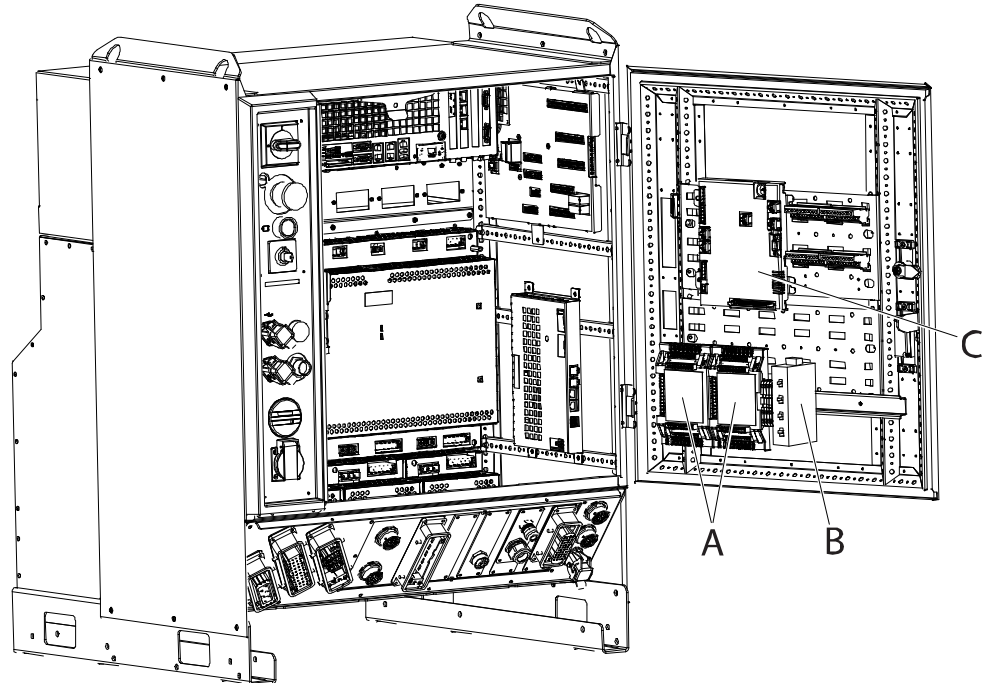

xx0600002681

	Spare part no.	Description	Note
A	3HAC025784-001	ADCombi I/O	DSQC 651
A	3HAC025917-001	Digital I/O	DSQC 652
A	3HAC025918-001	Digital I/O with relay outputs	DSQC 653
A	3HNE00554-1	Analog $\pm 10V$ I/O	DSQC 355A
B	3HAC034884-001	Ethernet switch	
C	3HNA006144-001	Process Interface Board	
	3HNA0011625-001	Process I/O	Mounted outside controller cabinet

© Copyright 2004-2010 ABB. All rights reserved.

Continues on next page

Computer unit DSQC 639 parts

The illustration below shows the placement of the computer unit parts in the recommended spare part list.

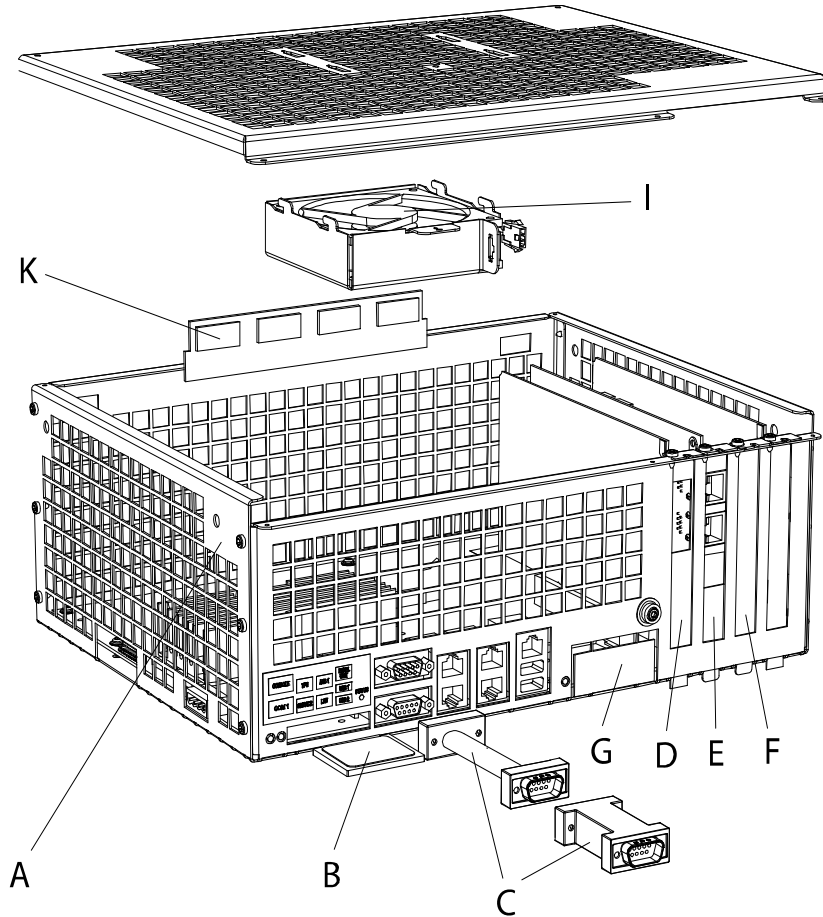

xx0600003029

	Spare part no.	Description	Note
A	3HAC025527-004	Computer unit	DSQC 639
B	3HAC025465-010	Compact flash 1GB	DSQC 656 1GB
B	3HAC025465-003	Compact flash 2GB	DSQC 656 2GB
C	3HAC14944-1	RS-232/422 Converter	DSQC 615
E, D, F	3HAC025779-001	DeviceNet Master/Slave Single	DSQC 658
E, D, F	3HAC025780-001	DeviceNet Master/Slave Dual	DSQC 659
E, D, F	3HAC15639-1	Ethernet card	DSQC 612
E, D, F	3HAC11819-1	Interbus Master/Slave copper wire	DSQC 529
E, D, F	3HAC5579-1	Interbus Master/Slave optical fibre	DSQC 512
E, D, F	3HAC023047-001	Profibus-DP Master/Slave	DSQC 637
E, D, F	3HAC031166-001	Profibus-DP Master/Slave	DSQC 687
E, D, F	3HAC030327-001	PROFINET Master/Slave	DSQC 678
G	3HAC031670-001	PROFINET Fieldbus Adapter	DSQC 688
I	3HAC025466-001	Fan	
K	3HAC025097-016	DDR SDRAM 256MB	

Continues on next page

7 Spare Parts

7.1.1. Single Cabinet Controller

Continued

Miscellaneous parts

The illustration below shows the placement of the Miscellaneous parts in the recommended spare part list.

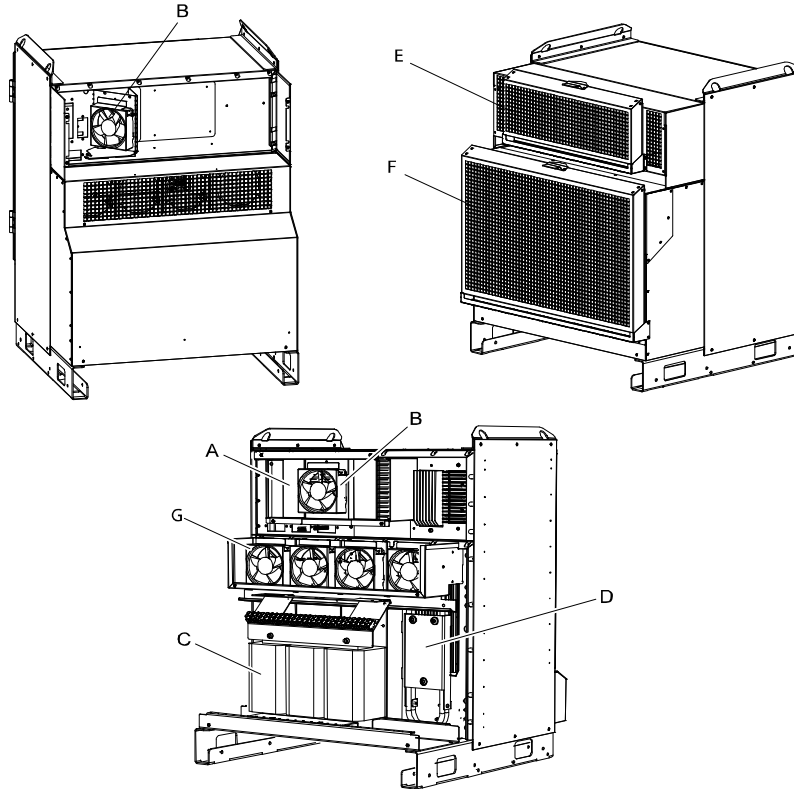

xx0600002683

	Spare part no	Description	Note
C	3HAC037015-001	Transformer unit 400-480V	1.2kVA
C	3HAC024174-001	Transformer unit 400-480V	2,5kVA drive
C	3HAC037016-001	Transformer unit 200-220V	4.2kVA
C	3HAC037017-001	Transformer unit 400V	4.2kVA
C	3HAC037018-001	Transformer unit 440-600V	4.2kVA
C	3HAC024180-001	Transformer unit 200-600V	6kVA
C	3HAC024138-001	Transformer unit 200-600V	13kVA
A	3HAC024729-001	Heat exchange unit	45°C
A	3HAC024439-001	Heat exchange unit	52°C
D	3HAC024628-001	Brake resistor bleeder asm	
	3HAC035583-001	Bleeder for Additional Rectifier Unit	
	3HAC036275-001	Mounting bracket for ARU bleeder	
B	3HAC021700-001	Fan with receptacle	52°C
B	3HAC029105-001	Fan with receptacle	45°C
G	3HAC029105-001	Fan with receptacle	
	3HAC15340-1	Cam Switch 3-pos Std	
	3HAC021606-001	Cam Switch 3-pos Extended	
	3HAC15312-1	Cam switch 2-pos Std	

© Copyright 2004-2010 ABB. All rights reserved.

Continues on next page

Continued

	Spare part no	Description	Note
	3HAC2349-1	Cam switch 2-pos Extended	
	3HAC028357-001	GTPU3 with 10m cable	
E	3HAC027697-001	Moist dust filter	Option
F	3HAC027641-001	Moist dust filter	Option

7 Spare Parts

7.2.1. Manipulator cables

7.2 Manipulator cables

7.2.1. Manipulator cables

Signal cables, IRB1400, 1600 and 4600

Art. no.	Description	Option no.
3HAC2493-1	Control cable signal L=7m	210-2
3HAC2530-1	Control cable signal L=15m	210-3
3HAC2540-1	Control cable signal L=22m	210-4
3HAC2566-1	Control cable signal L=30m	210-5

Signal cables, IRB 2400, 260, 4400, 6400RF, 660, 6600, 6650, 7600, 6620, 6640, 6660 and 6650S

Art. no.	Description	Option no.
3HAC7998-1	Control cable signal L=7m	210-2
3HAC7998-2	Control cable signal L=15m	210-3
3HAC7998-3	Control cable signal L=22m	210-4
3HAC7998-4	Control cable signal L=30m	210-5

Power cables, IRB 140

Art. no.	Description	Option no.
3HAC7996-1	Control cable power L=3m	210-1
3HAC7996-5	Control cable power L=7m	210-2
3HAC7996-6	Control cable power L=15m	210-3
3HAC7996-7	Control cable power L=22m	210-4
3HAC7996-8	Control cable power L=30m	210-5

Power cables, IRB 1400,1600 and 2400

Art. no.	Description	Option no.
3HAC2492-1	Control cable power L=7m	Standard: 210-2 and 287-4
3HAC2529-1	Control cable power L=15m	Standard: 210-3 and 287-4
3HAC2539-1	Control cable power L=22m	Standard: 210-4 and 287-4
3HAC2564-1	Control cable power L=30m	Standard: 210-5 and 287-4
3HAC9038-1	Control cable power L=7m	Foundry: 210-2 and 287-3 Wash: 210-2 and 287-5
3HAC9038-2	Control cable power L=15m	Foundry: 210-3 and 287-3 Wash: 210-3 and 287-5
3HAC9038-3	Control cable power L=22m	Foundry: 210-4 and 287-3 Wash: 210-4 and 287-5
3HAC9038-4	Control cable power L=30m	Foundry: 210-5 and 287-3 Wash: 210-5 and 287-5

© Copyright 2004-2010 ABB. All rights reserved.

Continues on next page

*Continued***Power cables, IRB 260**

Art. no.	Description	Option no.
3HAC9038-1	Control cable power L=7m	Foundry: 210-2 and 287-3 Wash: 210-5 and 287-5
3HAC9038-2	Control cable power L=15m	Foundry: 210-3 and 287-3 Wash: 210-5 and 287-5
3HAC9038-3	Control cable power L=22m	Foundry: 210-4 and 287-3 Wash: 210-5 and 287-5
3HAC9038-4	Control cable power L=30m	Foundry: 210-5 and 287-3 Wash: 210-5 and 287-5

Power cables, IRB 340

Art. no.	Description	Option no.
3HAC8158-1	Control Cable power L=7m	(435-33 or 435-34 or 435-35 or 435-47 or 435-48 or 435-49) and 210-2
3HAC8159-1	Control Cable power L=15m	(435-33 or 435-34 or 435-35 or 435-47 or 435-48 or 435-49) and 210-3
3HAC8160-1	Control Cable power L=22m	(435-33 or 435-34 or 435-35 or 435-47 or 435-48 or 435-49) and 210-4
3HAC8162-1	Control Cable power L=30m	(435-33 or 435-34 or 435-35 or 435-47 or 435-48 or 435-49) and 210-5

Power cables, IRB 360

Art. no.	Description	Option no.
3HAC029903-001	Control cable, power and signal L=3m	(435-803 or 435-81 or 435-82)
3HAC029903-002	Control cable, power and signal L=7m	(435-803 or 435-81 or 435-82)
3HAC029903-003	Control cable, power and signal L=15m	(435-803 or 435-81 or 435-82)
3HAC029903-004	Control cable, power and signal L=22m	(435-803 or 435-81 or 435-82)
3HAC029903-005	Control cable, power and signal L=30m	(435-803 or 435-81 or 435-82)

Power cables, IRB 4400

Art. no.	Description	Option no.
3HAC2512-1	Control cable power L=7m	Standard: 210-2 and 287-4 Clean room: 210-2 and 287-1
3HAC2535-1	Control cable power L=15m	Standard: 210-3 and 287-4 Clean room: 210-3 and 287-1
3HAC2560-1	Control cable power L=22m	Standard: 210-4 and 287-4 Clean room: 210-4 and 287-1

Continues on next page

7 Spare Parts

7.2.1. Manipulator cables

Continued

Art. no.	Description	Option no.
3HAC2572-1	Control cable power L=30m	Standard: 210-5 and 287-4 Clean room: 210-5 and 287-1
3HAC8182-1	Control cable power L=7m	Foundry: 210-2 and 287-3 Wash: 210-2 and 287-5
3HAC8182-2	Control cable power L=15m	Foundry: 210-3 and 287-3 Wash: 210-3 and 287-5
3HAC8182-3	Control cable power L=22m	Foundry: 210-4 and 287-3 Wash: 210-4 and 287-5
3HAC8182-4	Control cable power L=30m	Foundry: 210-5 and 287-3 Wash: 210-5 and 287-5

Power cables, IRB 6400RF

Art. no.	Description	Option no.
3HAC8184-1	Control cable power L=7m	210-2 and 287-3
3HAC8184-2	Control cable power L=15m	210-3 and 287-3
3HAC8184-3	Control cable power L=22m	210-4 and 287-3
3HAC8184-4	Control cable power L=30m	210-5 and 287-3

Power cable, IRB 6600, 7600, 660, 6620, 6640, 6660, 6650, 6650S and 4600

Art. no.	Description	Option no.
3HAC026787-001	Control cable power L=7m	(435-6 or 435-18 or 435-24 or 435-36) and 210-2
3HAC026787-002	Control cable power L=15m	(435-6 or 435-18 or 435-24 or 435-36) and 210-3
3HAC026787-003	Control cable power L=22m	(435-6 or 435-18 or 435-24 or 435-36) and 210-4
3HAC026787-004	Control cable power L=30m	(435-6 or 435-18 or 435-24 or 435-36) and 210-5

© Copyright 2004-2010 ABB. All rights reserved.

7.2.2. Position switch cables

IRB 1400

Axis 1

Art. no.	Description	Option no.
3HAC3363-1	Pos. switch cable L=7m	273-1
3HAC3364-1	Pos. switch cable L=15m	273-2
3HAC3365-1	Pos. switch cable L=22m	273-3
3HAC3366-1	Pos. switch cable L=30m	273-4

IRB 1600, 2400, 260, 4400, 6400RF and 340

Axis 1

Art. no.	Description	Option no.
3HAC7997-1	Pos. switch cable L=7m	273-1
3HAC7997-2	Pos. switch cable L=15m	273-2
3HAC7997-3	Pos. switch cable L=22m	273-3
3HAC7997-4	Pos. switch cable L=30m	273-4

IRB6600, 7600, 660 and 6620

Axis 1

Art. no.	Description	Option no.
3HAC13175-1	Pos. Switch 1 L=7m	273-1
3HAC13175-2	Pos. Switch 1 L=15m	273-2
3HAC13175-3	Pos. Switch 1 L=22m	273-3
3HAC13175-4	Pos. Switch 1 L=30m	273-4

Axis 2 and 3

Art. no.	Description	Option no.
3HAC13176-1	Pos. Switch 2/3 L=7m	274-1
3HAC13176-2	Pos. Switch 2/3 L=15m	274-2
3HAC13176-3	Pos. Switch 2/3 L=22m	274-3
3HAC13176-4	Pos. Switch 2/3 L=30m	274-4

7 Spare Parts

7.2.3. Fan cables

7.2.3. Fan cables

IRB6600 and 7600

Art. no.	Description	Option no.
3HAC022723-001	Harness - Axis 1&2 cooling	(87-1 or 88-1 or 89-1) and 210-2
3HAC022723-004	Harness - Axis 1&2 cooling	(87-1 or 88-1 or 89-1) and 210-3
3HAC022723-005	Harness - Axis 1&2 cooling	(87-1 or 88-1 or 89-1) and 210-4
3HAC022723-006	Harness - Axis 1&2 cooling	(87-1 or 88-1 or 89-1) and 210-5
3HAC022708-001	Harness - axis 1/2/3 cooling	(87-1 or 88-1 or 89-1) and 274-1 or 274-2 or 274-3 or 274-4

7.2.4. CP/CS Harness IRB 6400RF

CP/CS Canbus

Art. no.	Description	Option no.
3HAC9288-1	Harness CP/CS, CAN L=7m	16-1 and 90-2
3HAC9288-2	Harness CP/CS, CAN L=15m	16-1 and 90-3
3HAC9288-3	Harness CP/CS, CAN L=22m	16-1 and 90-4
3HAC9288-4	Harness CP/CS, CAN L=30m	16-1 and 90-5

7 Spare Parts

7.2.5. CP/CS Harness IRB 4600, 6600, 7600, 660, 6620 and 6640

7.2.5. CP/CS Harness IRB 4600, 6600, 7600, 660, 6620 and 6640

CP/CS

Art. no.	Description	Option no.
3HAC022957-001	Harness CP/CS L=7m	16-1 and 94-1
3HAC022957-002	Harness CP/CS L=15m	16-1 and 94-2
3HAC022957-006	Harness CP/CS L=22m	16-1 and 94-3
3HAC022957-003	Harness CP/CS L=30m	16-1 and 94-4

CP/CS Interbus

Art. no.	Description	Option no.
3HAC023024-001	Harness CP/CS, IBS L=7m	16-1 and 91-2
3HAC023024-002	Harness CP/CS, IBS L=15m	16-1 and 91-3
3HAC023024-006	Harness CP/CS, IBS L=22m	16-1 and 91-4
3HAC023024-003	Harness CP/CS, IBS L=30m	16-1 and 91-5

CP/CS/Profibus

Art. no.	Description	Option no.
3HAC022988-001	Harness CP/CS, PROFIB L=7m	16-1 and 92-2
3HAC022988-002	Harness CP/CS, PROFIB L=15m	16-1 and 92-3
3HAC022988-006	Harness CP/CS, PROFIB L=22m	16-1 and 92-4
3HAC022988-003	Harness CP/CS, PROFIB L=30m	16-1 and 92-5

CP/CS DeviceNet

Art. no.	Description	Option no.
3HAC022978-001	Harness CP/CS, DeviceNet L=7m	16-1 and 90-2
3HAC022978-002	Harness CP/CS, DeviceNet L=15m	16-1 and 90-3
3HAC022978-006	Harness CP/CS, DeviceNet L=22m	16-1 and 90-4
3HAC022978-003	Harness CP/CS, DeviceNet L=30m	16-1 and 90-5

7.2.6. Customer signal, CS/CP and CS

IRB 1400

Art. no.	Description	Option no.
3HAC3346-1	Customer cable sign. L=7m	16-1 and 17-5 and 94-1
3HAC3347-1	Customer cable sign. L=15m	16-1 and 17-5 and 94-2
3HAC3348-1	Customer cable sign. L=22m	16-1 and 17-5 and 94-3
3HAC3349-1	Customer cable sign. L=30m	16-1 and 17-5 and 94-4

IRB 1600, 2400

Art. no.	Description	Option no.
3HAC3353-1	Customer cable sign. L=7m	Standard: 94-1 and 287-4
3HAC3354-1	Customer cable sign. L=15m	Standard: 94-2 and 287-4
3HAC3355-1	Customer cable sign. L=22m	Standard: 94-3 and 287-4
3HAC3356-14	Customer cable sign. L=30m	Standard: 94-4 and 287-4
3HAC8183-1	Customer cable sign. L=7m	Foundry: 94-1 and 287-3 Wash: 94-1 and 287-5
3HAC8183-2	Customer cable sign. L=15m	Foundry: 94-2 and 287-3 Wash: 94-2 and 287-5
3HAC8183-3	Customer cable sign. L=22m	Foundry: 94-3 and 287-3 Wash: 94-3 and 287-5
3HAC8183-4	Customer cable sign. L=30m	Foundry: 94-4 and 287-3 Wash: 94-4 and 287-5

IRB 260

Art. no.	Description	Option no.
3HAC8183-1	Customer cable signal, L=7m	Foundry: 94-1 and 287-3 Wash: 94-1 and 287-5
3HAC8183-2	Customer cable signal, L=15m	Foundry: 94-2 and 287-3 Wash: 94-2 and 287-5
3HAC8183-3	Customer cable signal, L=22m	Foundry: 94-3 and 287-3 Wash: 94-3 and 287-5
3HAC8183-4	Customer cable signal, L=30m	Foundry: 94-4 and 287-3 Wash: 94-4 and 287-5

IRB 340, 360

Art. no.	Description	Option no.
3HAC14860-1	Customer cable sign. L=7m	218-9 and 94-1
3HAC14860-2	Customer cable sign. L=15m	218-9 and 94-2
3HAC14860-3	Customer cable sign. L=22m	218-9 and 94-3
3HAC14860-4	Customer cable sign. L=30m	218-9 and 94-4

7 Spare Parts

7.2.7. Customer power-signal

7.2.7. Customer power-signal

IRB 1600, 260, 2400 and 4400

Art. no.	Description	Option no.
3HAC8183-1	Customer pow.-sign. L=7m	94-1 and 16-1 and 17-5 and (287-3 or 243-5)
3HAC8183-2	Customer pow.-sign. L=15m	94-2 and 16-1 and 17-5 and (287-3 or 243-5)
3HAC8183-3	Customer pow.-sign. L=22m	94-3 and 16-1 and 17-5 and (287-3 or 243-5)
3HAC8183-4	Customer pow.-sign. L=30m	94-4 and 16-1 and 17-5 and (287-3 or 243-5)
3HAC3353-1	Customer pow.-sign. L=7m	94-1 and 16-1 and 17-5 and (287-4 or 243-1)
3HAC3354-1	Customer power-sign. L=15m	94-2 and 16-1 and 17-5 and (287-4 or 243-1)
3HAC3355-1	Customer power-sign. L=22m	94-3 and 16-1 and 17-5 and (287-4 or 243-1)
3HAC3356-1	Customer power-sign. L=30m	94-4 and 16-1 and 17-5 and (287-4 or 243-1)

IRB 340

Art. no.	Description	Option no.
3HAC3358-4	Internal Customer cable L=3m	218-5 and 94-6
3HAC3358-1	Internal Customer cable L=7m	218-5 and 94-1
3HAC3359-1	Internal Customer cable L=15m	218-5 and 94-2
3HAC3360-1	Internal Customer cable L=22m	218-5 and 94-3
3HAC3361-1	Internal Customer cable L=30m	218-5 and 94-4

IRB 360

Art. no.	Description	Option no.
3HAC030198-001	Internal Customer cable L=3m	218-5 and 94-6
3HAC030198-002	Internal Customer cable L=7m	218-5 and 94-1
3HAC030198-003	Internal Customer cable L=15m	218-5 and 94-2
3HAC030198-004	Internal Customer cable L=22m	218-5 and 94-3
3HAC030198-005	Internal Customer cable L=30m	218-5 and 94-4

Euromap cables

Art. no.	Description	Option no.
3HAC024328-001	Cable EMP67, L=10m	671-2 and 673-1
3HAC024328-005	Cable EMP67, L=15m	671-2 and 673-2
3HAC024330-001	Cable EMP12, L=10m	671-1 and 673-1
3HAC024330-004	Cable EMP12, L=15m	671-1 and 673-2

7.2.8. Additional axis cables

Power cable (stationary gun)

Art. no.	Description	Option no.
3HEA800736-001	Power cable (floor) L=7m	809-1
3HEA800736-002	Power cable (floor) L=15m	809-2
3HEA800736-003	Power cable (floor) L=22m	809-3
3HEA800736-004	Power cable (floor) L=30m	809-4

Power cable (robot gun)

Art. no.	Description	Option no.
3HEA800824-001	Power cable (floor) L=7m	787-1
3HEA800824-002	Power cable (floor) L=15m	787-2
3HEA800824-003	Power cable (floor) L=22m	787-3
3HEA800824-004	Power cable (floor) L=30m	787-4

Serial measurement cable

Art. no.	Description	Option no.
3HXD1411-70	Serial measurement cable	787-1
3HXD1411-150	Serial measurement cable	787-2
3HXD1411-220	Serial measurement cable	787-3
3HXD1411-300	Serial measurement cable	787-4

Miscellaneous cables

Art. no.	Description	Option no.
3HEA800964-003	SMB 2axis, standard IP65	785-3 or 785-6
3HXD1249-70	7:th axis floor cable	785-6
3HXD1249-70	7:th axis floor cable	785-3 or 785-2
3HXD1250-70	Resolver cable floor	785-2 or 785-5
3HXD1250-70	Resolver cable floor	785-6
3HXD1249-15	Motor cable, 7:th axis	785-3
3HXD1250-15	Resolver cable (Foundry)	785-3

7 Spare Parts

7.2.8. Additional axis cables

8 Circuit Diagram

8.1. About circuit diagrams

Overview

The circuit diagrams are not included in this manual but delivered as separate documents on the documentation DVD. See below for correct article numbers.

Controllers

Product	Article numbers for circuit diagrams
IRC5 with Drive System 04	3HAC024480-004
IRC5 with Drive System 09	3HAC024480-005
IRC5 Panel Mounted Controller	3HAC026871-005
IRC5 Compact	3HAC031403-003

Manipulators

Product	Article numbers for circuit diagrams
IRB 120	3HAC031408-003
IRB 140	3HAC6816-3
IRB 260	3HAC025611-001
IRB 360	3HAC028647-009
IRB 660	3HAC025691-001
IRB 1410	3HAC2800-3
IRB 1600	3HAC021351-003
IRB 2400	3HAC6670-3
IRB 2600	3HAC029570-007
IRB 4400/4450S	3HAC9821-1 3HAC9821-1
IRB 4600	3HAC029038-003
IRB 6400RF	3HAC8935-1
IRB 6600 type A	3HAC025744-001
IRB 6600 type B	3HAC025744-001
IRB 6620	3HAC025090-001
IRB 6620LX	3HAC025090-001
IRB 6640	3HAC025744-001
IRB 6650S	3HAC025744-001
IRB 6660	3HAC029940-001 (DressPack) 3HAC025744-001
IRB 7600	3HAC025744-001

8 Circuit Diagram

8.1. About circuit diagrams

A

additional drive module 106
 additional drive unit 98
 ARU bleeder 264
 axis computer, repair 232

B

backup energy bank, repair 189
 bleeder 262
 bolt pattern 43
 brake resistor bleeder 262
 busbar, repair 227

C

cables 67
 capacitor 91
 capacitor, repair 226
 carbon dioxide extinguisher 17
 cleaning of the controller 174
 cleaning the FlexPendant 176
 Compact Flash memory, replace 223
 Configuration of the drive system 91, 98
 connecting a USB memory 102
 connection
 external safety devices 15
 FlexPendant 52
 manipulator cables 67
 PC to service port 53
 Connectors on controller 49
 contactor auxiliary blocks 76
 contactor Interface Board, repair 252
 Control power supply, Repair 272
 controlled stop 18

D

danger levels 28
 DDR SDRAM memory, replace 207
 Drive functions 88
 drive system 98
 Drive System 04 89
 Drive System 09 90
 drive system fan, repair 255
 drive system power supply, repair 284
 drive unit 98
 drive units 91
 DSQC 612 ethernet board 107
 Dual Cabinet Controller, overview 37, 179

E

Electronic Position Switches 146, 238
 emergency stop
 definition 23
 devices 24
 EPS board 146, 238
 ESD
 damage elimination 31
 sensitive equipment 31
 wrist strap connection point 31
 Ethernet 54
 external operator's panel 110
 external safety relay 74

F

fieldbus adapter, replace 215
 filters 91
 fire extinguishing 17
 Fitting the connector 65
 FlexPendant
 connecting 52

H

hardware stops 18
 Heat exchange unit and fan, repair 196

I

I/O signals 68
 I/O units and gateways, repair 186
 Inspection of controller modules 168
 Installation Activities 38
 Installation of Drive system parts 114, 116
 Installation of I/O, Gateways and encoder units 118
 installation space 42
 integrated PLC 250
 IP class 41
 IRC5 controller modules 38

L

lifting device 39

M

main drive unit 98
 main power
 switching off 30
 main switch
 control module 30
 controller cabinet 30
 drive module 30
 manipulator cables 67
 MDU bleeder 264
 memory 207, 223
 memory functions 101
 MOTORS ON/MOTORS OFF 75
 MOTORS ON/MOTORS OFF circuit 69
 Multi Move system 106

O

operating conditions 40

P

panel board, repair 180
 PC, connecting 53
 PCI boards, replace 211
 PLC 250
 Power supply 61
 protection class 41
 protection standards 294
 protective stop 25

R

rectifier, repair 226
 rectifiers 91, 98
 Replacement of Contactor Interface Board 252
 Replacement of customer I/O power supply 278

replacing
 Compact Flash memory 223
 DDR SDRAM memory 207
 fieldbus adapter 215
 PCI boards 211

responsibility and validity 15

S

safety
 emergency stop 23
 ESD 31
 fire extinguishing 17
 introduction 13
 manipulator system 15
 service 15
 signals 28
 signals in manual 28
 stop functions 18
 symbols 28
 wrist strap 31

Safety Controller 146, 238

safety risk
 live electric part 16

safety signals 68
 in manual 28

safety standards 294

safety stop 25

service port 53

servo disconnect 81

servo drive units 91

servo drive units, repair 226

shielded cables 68

signal cables 68

signals
 safety 28

Single Cabinet Controller, overview 37, 179

standard, overview 37, 179

standards
 ANSI 295
 CAN 295
 EN 294
 EN IEC 294
 EN ISO 294
 protection 294
 safety 294

stop category 0 18

stop category 1 18

stop connections
 overview 18

stop modes
 overview 18

stops
 overview 18

storage conditions 40

symbols
 safety 28

T

temperature 40

U

uncontrolled stop 18

USB ports 102

V

validity and responsibility 15

W

weight 40



ABB AB
Robotics Products
S-721 68 VÄSTERÅS
SWEDEN
Telephone: +46 (0) 21 344000

3HAC021313-001, Revision P, en